

ZUNDAPP

ONDERDELEN-CATALOGUS

Voor de typen 529

CS 50
GTS 50
KS 50

Uitgave 1/1978



Catalogus voor de typen

Type	vanaf Framenr.	Motorstype	vanaf Motornr.	Kleur
CS 50 529-03 L0	9 110 031	266-72 L0	9 595 301	33
GTS 50 529-05 L0	9 102 751	280-77 L0	9 586 404	66, 67
KS 50 529-05 L1	9 102 731	280-77 L1	9 586 334	66, 67

Kleur-aanduiding

33 = briljant-blauw

66 = groen metallic

67 = goud-oranje lasuur

Uitgegeven door ZÜNDAPP WERKE HMBH MÜNCHEN in samenwerking met de
2 ZÜNDAPP importeurs voor nederland Groninger Motorimport B. V.,
Handelssonderneming Riemersma b. v. afd. Ramo.

Inhoudsopgave

	Bldz.		
	CS	GTS	KS
<u>Motorisch-gedeelte</u>			
Carterdeksel links - kickstarter - voetschakelas	-	4	4
Koelingskap - schoepenrad	6	-	-
Carterhelft links - carterdeksel links - lagers	7	-	-
Carterhelft links - pakking	-	8	8
Carterhelft rechts	9	10	10
Carterdeksel rechts - koppelingshevel	11	11	11
Koppeling	12	12	12
Cylinder - krukas	13	13	13
Carburateur	14	15	15
Aanzuigflens en rubber - geruisdemper	16	16	16
Schakelhevel - schakelvork - trapas	17	-	-
Versnellingsbak - onderdelen - kettingwiel	18	19	19
Ontsteking 6 V, 24 W	20	-	-
Ontsteking 6 V, 33 W	-	21	21
Uitlaatbocht - demper en bevestigingen	22	22	22
<u>Frame-gedeelte</u>			
Frame - framebeplating - stuurslot - balhoofdstel	23	23	23
Motorophanging	25	25	25
Trapas - krank - pedalen	26	26	26
Telescoopvoervork	27	27	28
Achtervork - kettingkast - schokbrekers	29	29	29
Voorwiel - naaf \emptyset 120 mm - tot framenr. 9 149 449	30	-	-
Voorwiel - naaf \emptyset 150 mm - voor CS vanaf framenr. 9 149 450 .	31	31	-
Alu voorwiel - remschijf \emptyset 220 mm	-	-	32
Remklauw	-	-	33
Achterwiel - naaf \emptyset 120 mm - tot framenr. 9 149 449	34	-	-
Achterwiel - naaf \emptyset 150 mm - v. CS vanaf framenr. 9 149 450 .	36	36	36
Inbouwset - houder	38	38	38
Achterlicht - dim schakelaar - kabelboom	39	39	39
R. A. W . installatie	-	40	40
Cockpit - uitrusting	41	41	42
Stuur - afdekplaatje - bel	43	43	43
Voetrem	44	44	44
Handles en bedieningskabels	45	46	-
Gashandle - remsleiding	-	-	47
Koppelingshandel - bedieningskabels	-	-	48
Spatschermen - bevestigingen	49	49	50
Benzinetank - gereedschapset - luchtpomp - beugel	51	51	51
Buddyseat - standaard - voetsteunen	52	-	-
Buddyseat - spoiler - standaard - voetsteunen	-	53	53

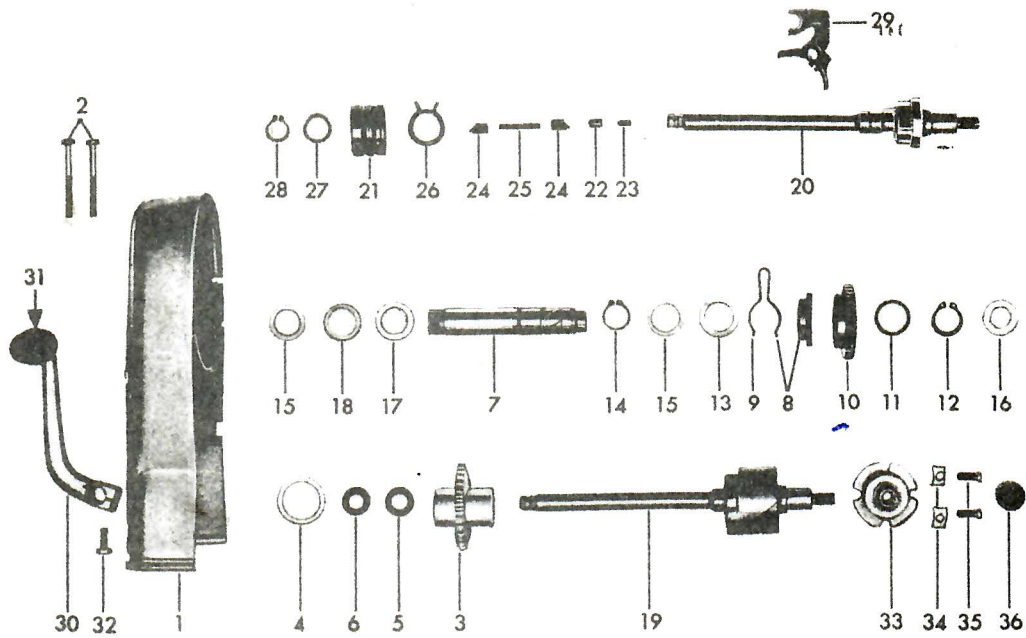

01.266.2

Afb.	Bestelnummer	Omschrijving	GTS	KS
1	280-01.255	Carterdeksel links zwart	1	1
2	DIN 84 BM 6x45	Carterbout	2	2
3	280-05.612	Tandwiel 30 t.	1	1
4	278-01.128	Afstandsbus 28,2x35x4	1	1
5	284-05.101	Dichtring	1	1
6	283-05.167	Oliekeerring 12x20x4	1	1
7	280-05.103	Kickstarteras	1	1
8	283-05.901	Meenemer met remveer	1	1
9	267-05.334	Remveer	1	1
10	281-05.162	Startertandwiel 31 t.	1	1
11	265-05.203	Tussenring 20x28x2	1	1
12	DIN 471 20x1,75	Borgring	1	1
13	265-05.255	Vulschijf 22,1x32x0,2	n. beh.	
14	DIN 471 20x1,2	Borgring	2	2
15	267-05.310	Vulschijf 20,2x28x0,1	n. beh.	
--	278-01.129	Vulschijf 20,2x28x0,2	n. beh.	
--	278-01.130	Vulschijf 20,2x28x0,5	n. beh.	
--	278-01.131	Vulschijf 20,2x28x1,0	1	1
16	265-05.245	Vulschijf 16,2x28x1,0	1	1
17	278-01.125	Vulschijf 20,5x31x1,0	1	1
18	278-01.131	Vulschijf 20,2x28x1,0	1	1
19	281-05.708	Voetschakelas compleet	1	1

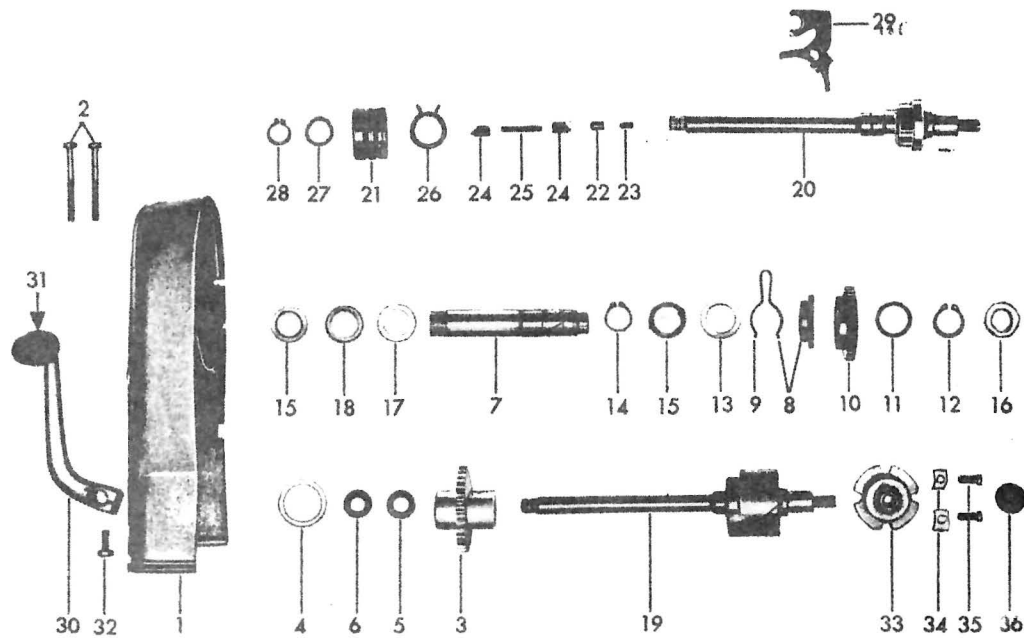

01.266.2

Afb.	Bestelnummer	Omschrijving	GTS	KS
20	267-05.654	Voetschakelas kaal	1	1
--	DIN 5402 3x27,8	Borgpen	1	1
21	281-05.137	Huls	1	1
22	267-05.125	Aanslagbout	1	1
23	267-05.126	Drukveer voor aanslagbout	1	1
--	DIN 660 2,6x6	Niet	1	1
24	267-05.586	Schakelpal	2	2
25	267-05.585	Drukveer voor schakelpal	1	1
26	278-05.100	Terugslagveer	1	1
27	267-05.244	Vulschijf 16,2x22,8x0,1	n.beh.	
28	DIN 471 16x1	Borgring	1	1
29	267-05.633	Schakelvork	1	1
30	283-05.716	Voetschakelpedaal compleet	1	1
31	616 z 25	Rubber	1	1
32	DIN 933 M 6x16	Bout	1	1
33	267-05.112	Instelplaat	1	1
34	267-05.113	Onderlegplaatje	2	2
35	DIN 920 M 6x15	Bout voor instelplaat	2	2
36	267-05.130	Rubber dop	1	1

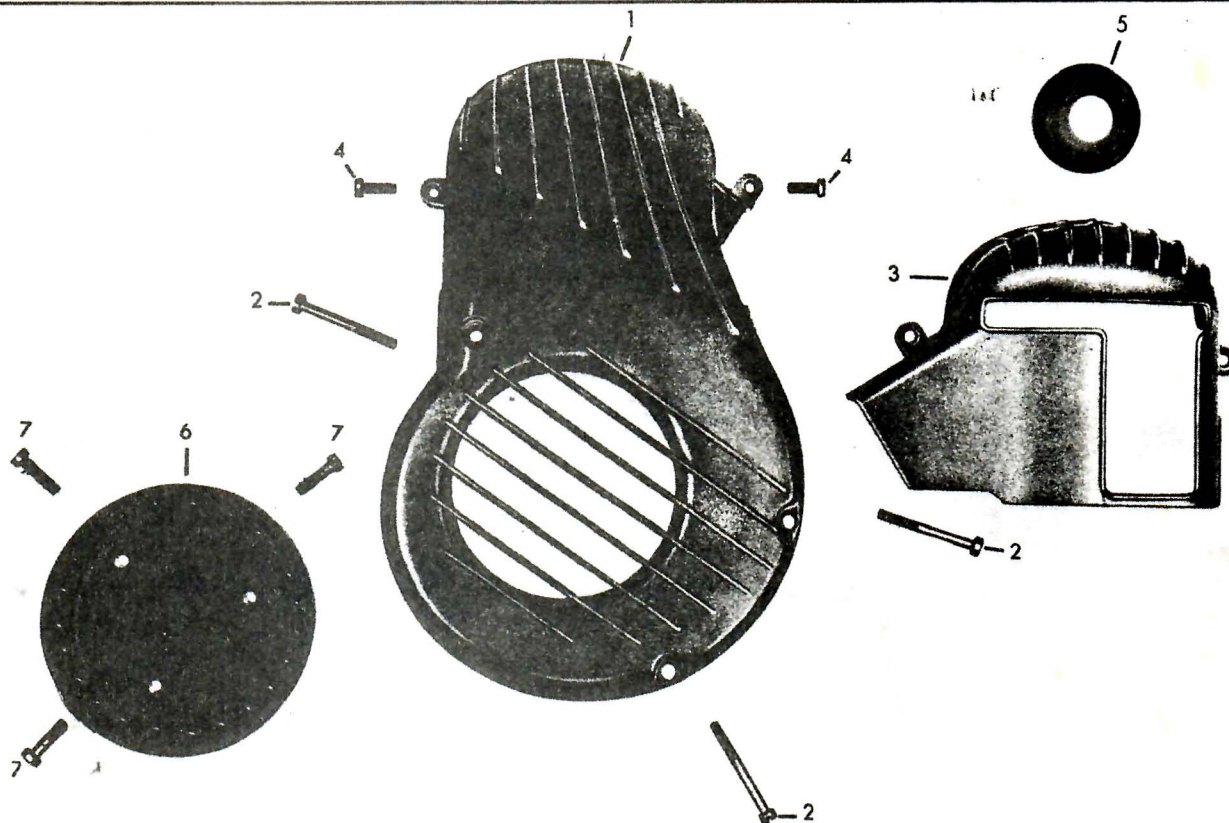

Afb.	Bestelnummer	Omschrijving	CS
1	266-01.209	Koelingskap	1
2	DIN 84 BM 6x45	Bout	3
3	266-01.602	Kleine koelingskap	1
-	266-01.217	Rubbertje voor koelingskap	2
4	DIN 84 AM 5x14	Bout	2
5	266-01.214	Rubber	1
6	266-07.603	Schoepenrad	1
-	284-07.116	Vulschijf 6,1x11,8x1,25	3
7	DIN 84 AM 6x12	Bout	3
-	266-01.211	Afsluitdeksel	1

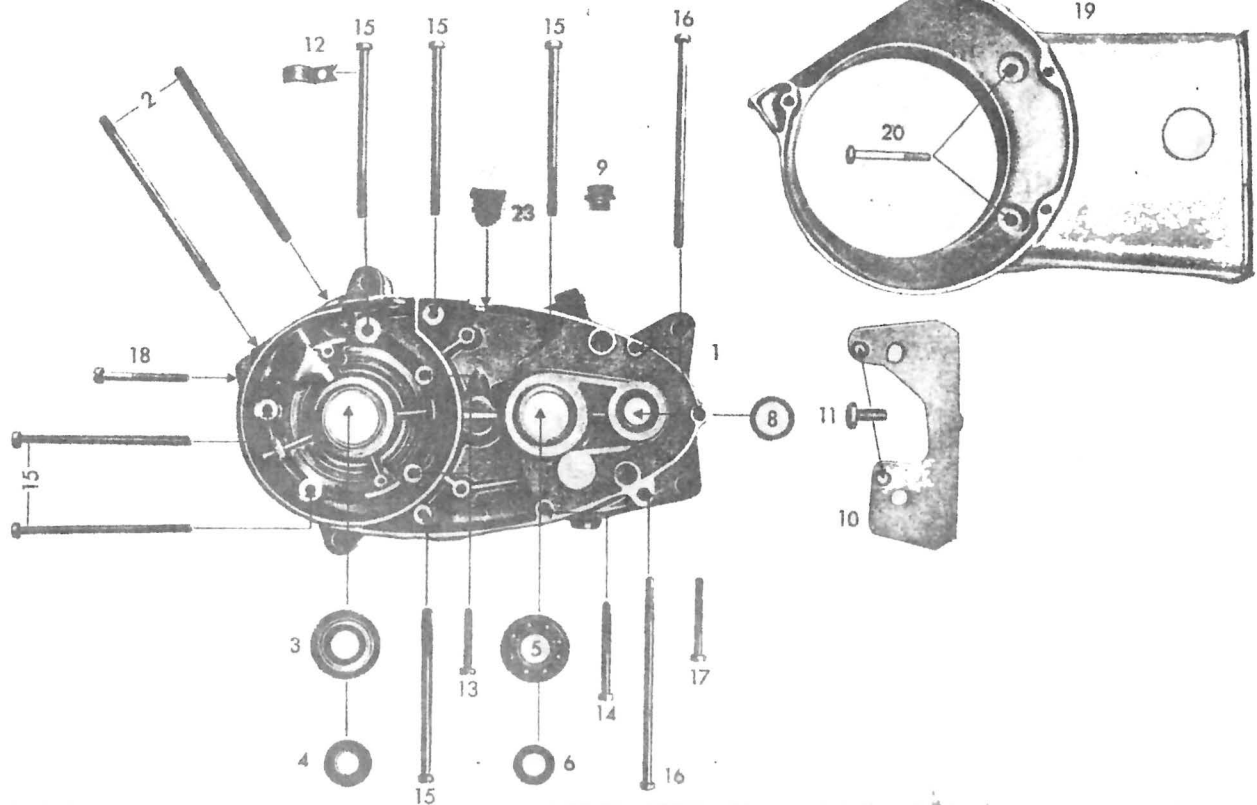

Afb.	Bestelnummer	Omschrijving	CS
1	265-01.908	Carterhelft links kaal	1
-	265-01.117	Carterpakking	1
2	265-01.100	Tapeind M 7x120	2
3	DIN 625 6203 Z/C3	Kogellager 17x40x12	1
4	277-01.136	Simmering 17x28x7	1
5	DIN 625 6203 C3	Kogellager 17x40x12	1
6	265-01.135	Simmering 16x24x7	1
8	265-01.136	Simmering 16x22x3	1
9	281-01.135	Olievulschroef	1
10	266-01.208	Tussenplaat	1
11	DIN 964 M 5x10	Bout	2
12	265-01.145	Kabelklem	1
13	DIN 84 AM 6x35	Carterbout	2
14	DIN 84 BM 6x65/20	Carterbout	1
15	DIN 84 BM 6x98/25	Carterbout	6
16	DIN 84 BM 6x120/25	Carterbout	3
17	DIN 84 BM 6x50	Carterbout	1
18	DIN 84 BM 6x45	Carterbout	1
19	267-01.137	Carterdeksel links kaal	1
20	DIN 931 M6x45	Bout	2
23	284-01.100	Afsluitkap	1

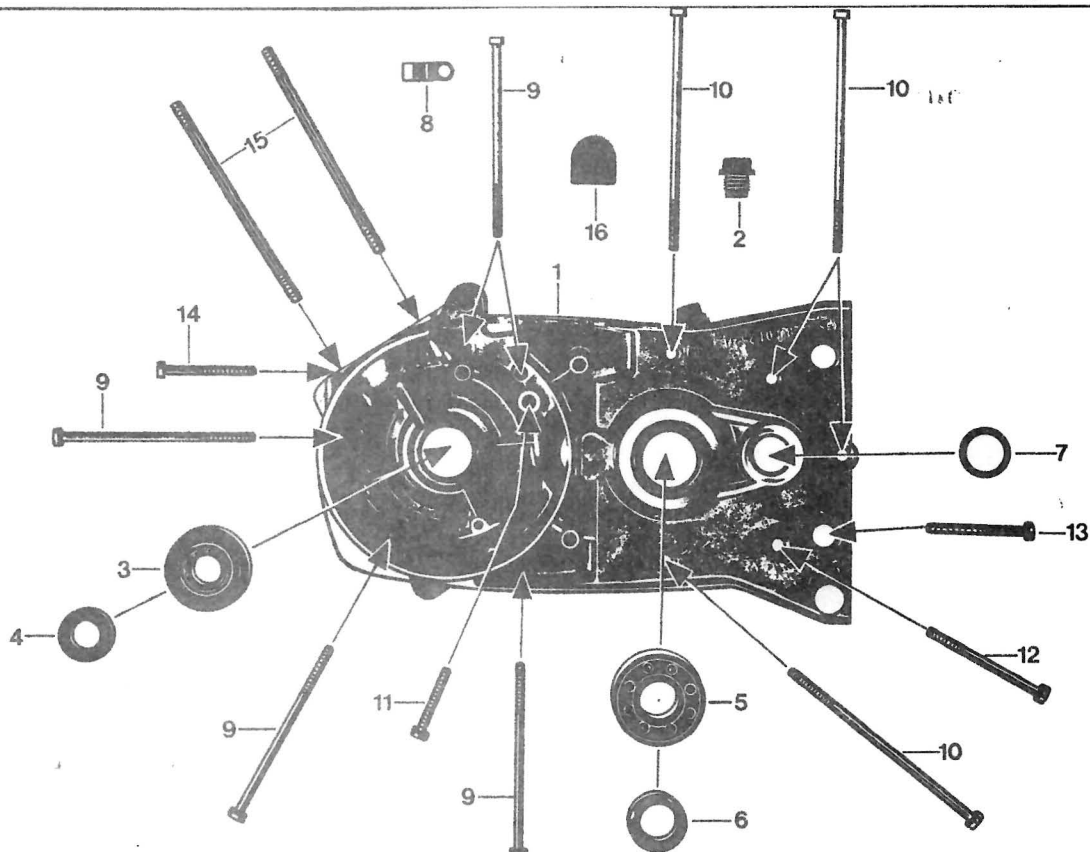

01.280.2

Afb.	Bestelnummer	Omschrijving	GTS	KS
1+2	276-01.910	Carterhelft links	1	1
2	281-01.135	Olievulschroef	1	1
-	265-01.117	Carterpakking	1	1
3	DIN 6203 Z/C3	Kogellager 17x40x12	1	1
4	277-01.136	Oliekeerring 17x28x7	1	1
5	DIN 625 6204 C3	Kogellager 20x47x14	1	1
6	285-01.183	Oliekeerring 20x30x7	1	1
7	285-01.153	Oliekeerring 20x26x4	1	1
8	276-01.145	Kabelklem	1	1
9	DIN 84 BM 6x98/25	Carterbout	5	5
10	DIN 84 BM 6x120/25	Carterbout	4	4
11	DIN 84 AM 6x35	Carterbout	2	2
12	DIN 84 BM 6x65/20	Carterbout	1	1
13	DIN 84 BM 6x50	Carterbout	1	1
14	DIN 84 BM 6x45	Carterbout	1	1
15	265-01.100	Tapeind M 7x120, ϕ 6,35	1	1
15	278-01.137	Tapeind M 7x120, ϕ 8	1	1
16	284-01.100	Afsluitkap	1	1
--	280-09.900	<u>Pakking-set</u> , bestaande uit:	1	1
		Carterpakking		
		Cylinderkoppakking		
		Cylindervoetpakking		
		Aanzuigpakking		

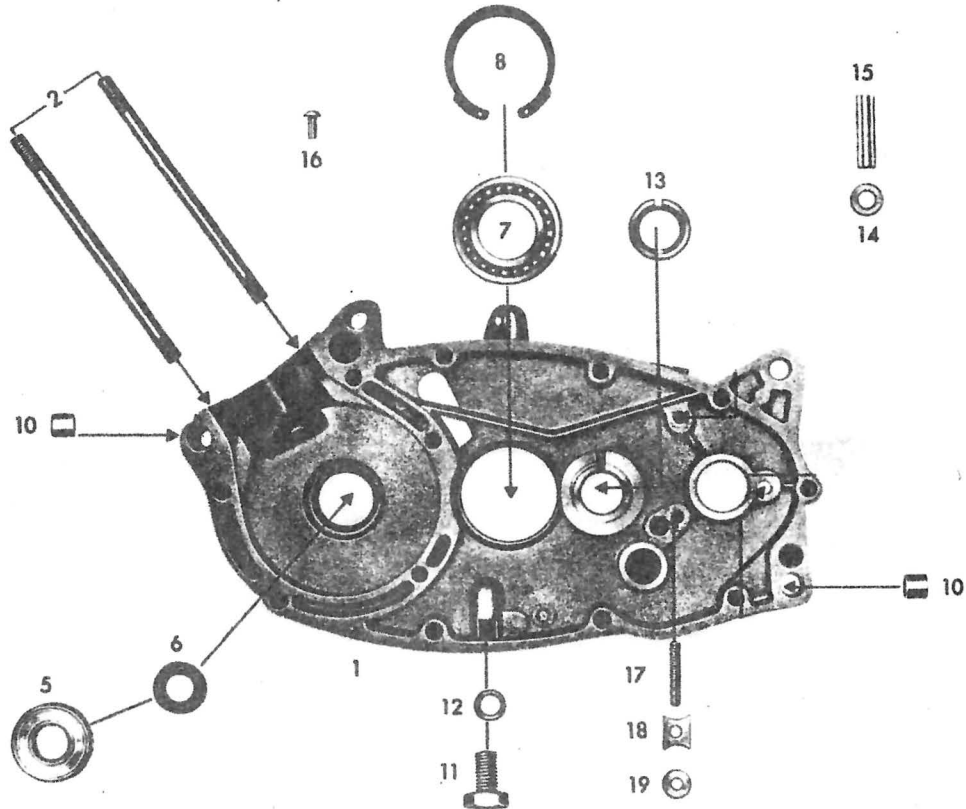

Afb.	Bestelnummer	Omschrijving	CS
1	265-01.907	Carterhelft rechts kaal	1
-	265-01.118	Carterpakking	1
2	265-01.100	Tapeind M 7x120	2
5	DIN 625 6202 Z/C3	Kogellager 15x35x11	1
6	255-01.144	Oliekeerring 15x24x7	1
7	DIN 625 16005 C3	Kogellager 25x37x8	1
8	276-01.154	Borging	1
10	M 181 z 138	Pasbus	4
11	DIN 933 M 10x18	Olie-aftapbout	1
12	DIN 7603 A 10x13,5	Afdichtring	1
13	265-01.102	Lagerbus	1
14	265-01.105	Bronzen lager	1
15	265-01.104	Afstandsbus	1
16	DIN 1476 5x15	Niet	1
17	DIN 551 M 6x40	Tapeind	1
18	DIN 439 BM 6	Moer	1
19	265-01.138	Borgplaatje	1
--	247-01.126	Typeplaatje	1
--	265-01.143	Borgplaatje	1
--	DIN 6797 A 6,4	Vulschijf	1
--	DIN 933 M 6x16	Bout	1

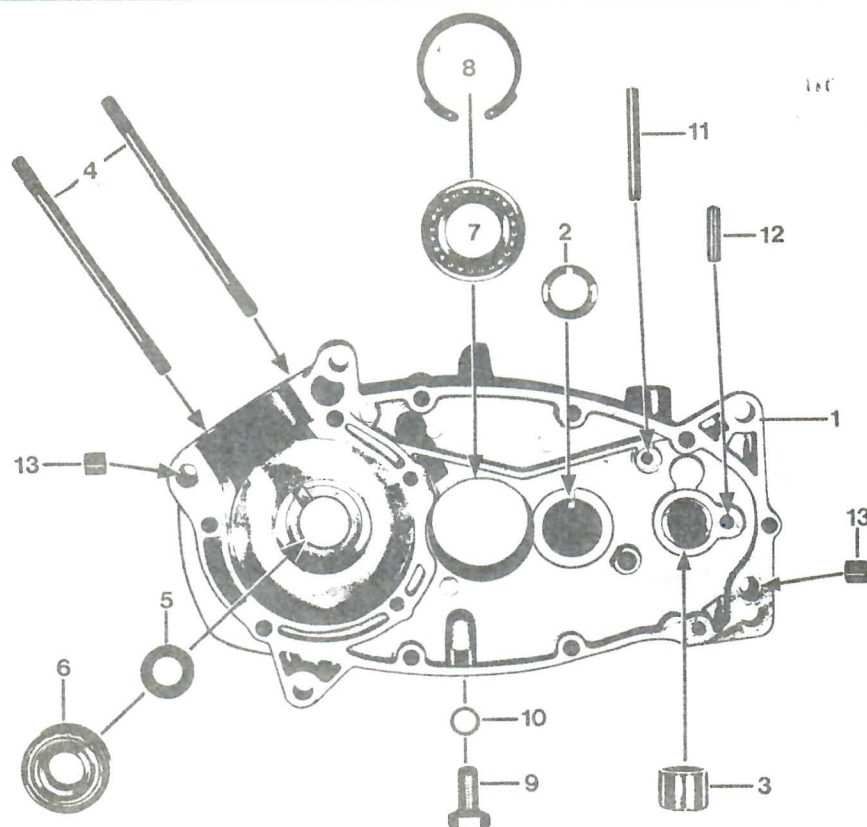

01.280.1

Afb.	Bestelnummer	Omschrijving	GTS	KS
1-3	280-01.902	Carterhelft rechts kaal	1	1
2	265-01.102	Lagerbus \varnothing 18	1	1
3	267-01.128	Lagerbus \varnothing 16	1	1
-	265-01.118	Carterpakking	1	1
4	265-01.100	Tapeind M 7x120	2	2
5	255-01.144	Oliekeerring 15x24x7	1	1
6	DIN 625 6302 Z/C3	Kogellager 15x42x13	1	1
7	DIN 625 16005 C3	Kogellager 25x47x8	1	1
8	276-01.154	Borgring J 47x1,75	1	1
9	DIN 933 M 10x18	Olie-aftapbout	1	1
10	DIN 7603 A 10x13,5	Afdichtring	1	1
11	DIN 1481 5x45	Huls	1	1
12	267-05.129	Stift 6x24	1	1
13	M 181 z 138	Pasbus	4	4
--	247-01.126	Typeplaatje	1	1

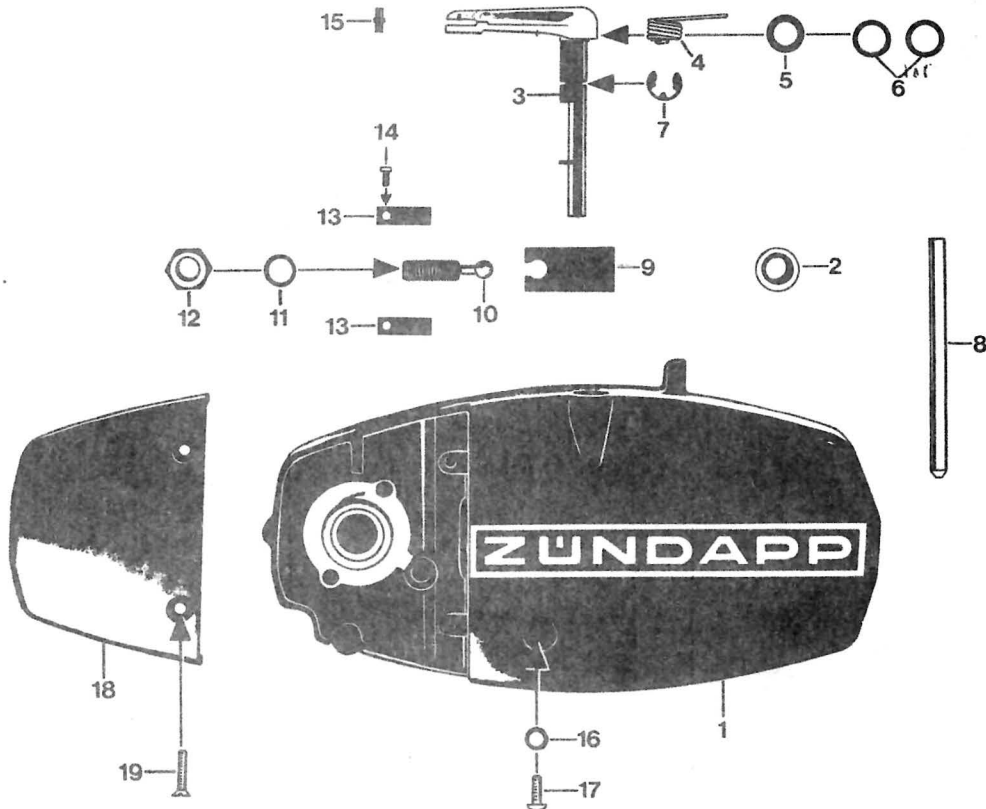

01.278.3

Afb.	Bestelnummer	Omschrijving	CS	GTS	KS
1	278-01.144	Carterdeksel rechts kaal zwart	-	1	1
-	265-01.151	Carterdeksel rechts kaal	1	-	-
2	265-01.136	Afdichtring 16x22x3	1	-	-
3	265-06.602	Koppelingshevel	1	1	1
4	265-06.112	Veer	1	1	1
5	405-15.388	O-Ring \varnothing 11x2,5	1	1	1
6	281-06.114	Vulschijf 0,2	1	1	1
-	281-06.115	Vulschijf 0,5	n. beh.		
7	DIN 6799 8	Borgveer	1	1	1
8	276-05.172	Geleidestift \varnothing 8x9,5	-	1	1
9	265-06.104	Koppelingstong	1	1	1
10	265-06.106	Stelschroef	1	1	1
11	DIN 7603 A 10x13,5	Afdichtring	1	1	1
12	DIN 936 M 10x1	Moer voor stelschroef	1	1	1
13	265-06.109	Bladveer	2	2	2
14	DIN 84 AM 4x6	Bout	2	2	2
15	DIN 1481 3x12	Passtift	1	1	1
16	DIN 7603 A 6x10	Afdichtring	1	1	1
17	DIN 85 AM 6x12	Bout	1	1	1
18	284-01.176	Aansluitkap	-	1	1
--	265-01.115	Aansluitkap	1	-	-
19	DIN 964 AM 5x20	Bout	2	2	2

Koppeling

CS GTS KS

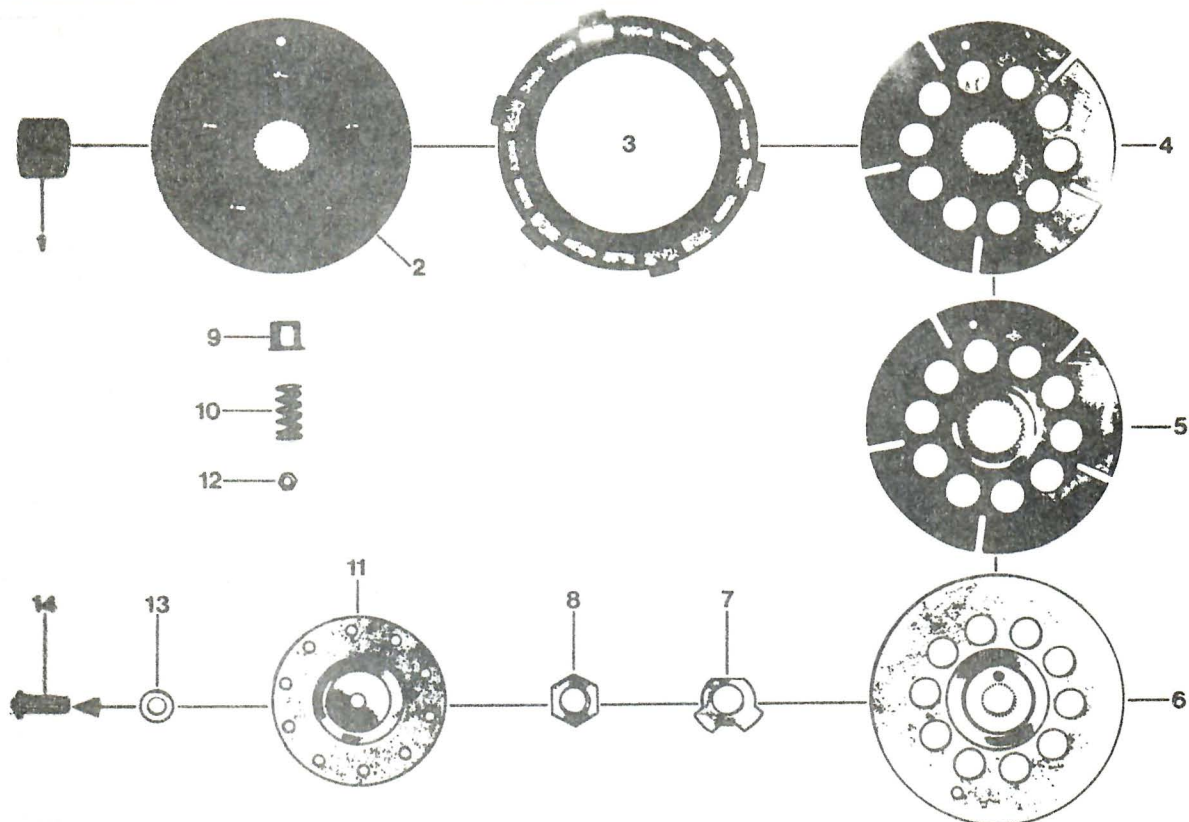

06.265.1

Afb.	Bestelnummer	Omschrijving	CS	GTS	KS
1	265-06.201	Koppelingskern	1	1	1
2	265-06.606	Grondplaat	1	1	1
3	265-06.135	Koppelingsplaat	4	4	4
4	265-06.130	Stalen koppelingsplaat	2	2	2
5	265-06.131	Stalen koppelingsplaat	1	1	1
6	265-06.127	Dekplaat	1	1	1
7	284-06.104	Borgplaatje	1	1	1
8	265-06.202	Moer	1	1	1
9	261-06.155	Veerhoedje	10	10	10
10	281-06.101	Koppelingsveer	10	10	10
11	265-06.216	Drukplaat	1	1	1
12	DIN 934 M 4	Moer	5	5	5
13	265-05.296	Vulschijf 6,1x11,8x0,8	1	1	1
--	265-05.295	Vulschijf 6,1x11,8x0,4	n.	beh.	
--	265-05.294	Vulschijf 6,1x11,8x0,2	n.	beh.	
14	247-05.233	Koppelingsdrukstift	1	1	1

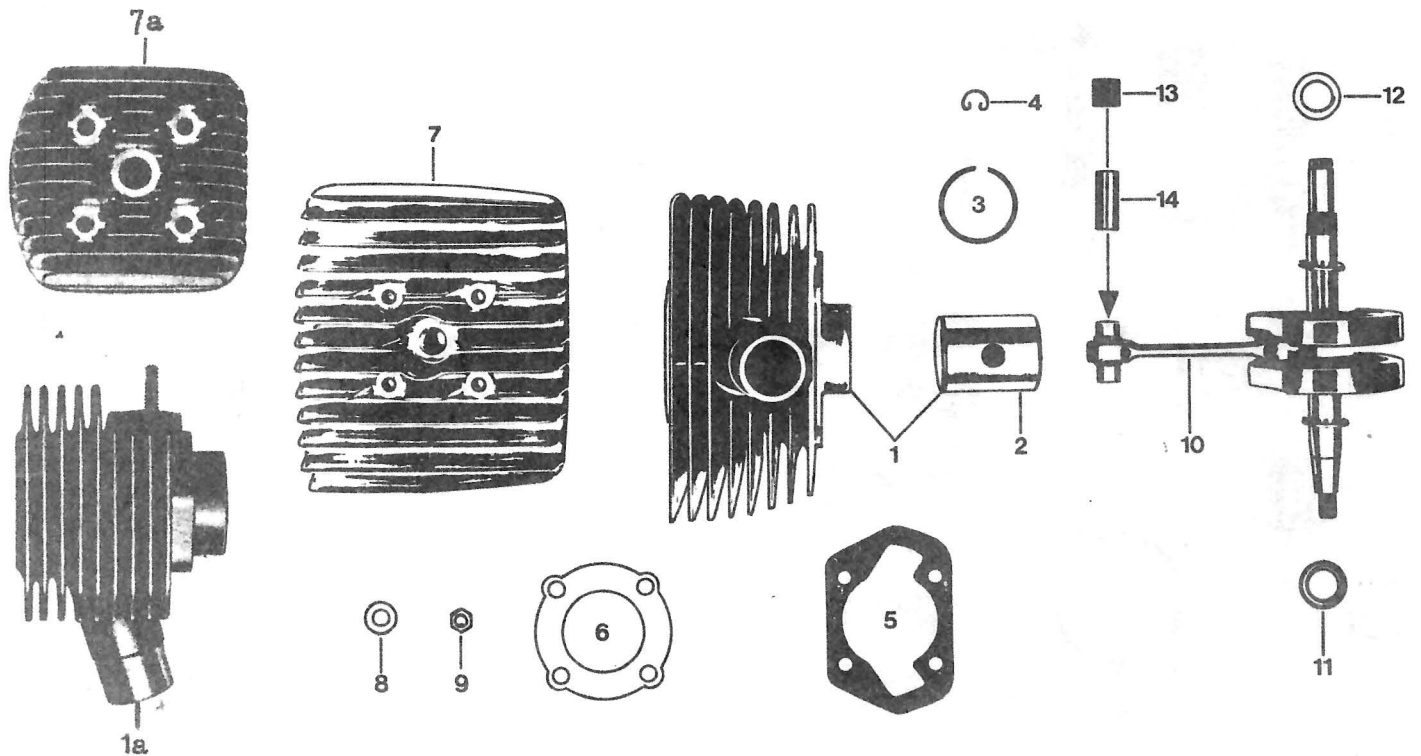

Afb.	Bestelnummer	Omschrijving	CS	GTS	KS
1	278-02.721	Cylinder met zuiger	-	1	1
1a	266-02.700	Cylinder met zuiger	1	-	-
2	248-02.703	Zuiger compleet	1	1	1
3	248-02.107	Zuigerveer 39x1,5	1	1	1
4	DIN 73123 A 12	Zuigerpenborgveer	2	2	2
5	276-02.219	Cylindervoetpakking	-	1	1
-	265-02.110	Cylindervoetpakking	1	-	-
6	278-02.109	Cylinderkoppakking	-	1	1
-	284-02.158	Cylinderkoppakking	1	-	-
7	278-02.107	Cylinderkop	-	1	1
7a	265-02.201	Cylinderkop	1	-	-
8	265-02.120	Sluitring	4	4	4
9	DIN 934 M 7	Moer	4	4	4
10	278-03.902	Krukas compleet	1	1	1
--	278-03.903	Drijfstangset	1	1	1
11	277-03.111	Facettenschijf 17,1x24x1,5x2	1	1	1
--	265-05.177	Vulschijf 17,1x24x0,1	n.	beh.	
--	265-05.176	Vulschijf 17,1x24x0,2	n.	beh.	
--	265-05.175	Vulschijf 17,1x24x0,5	n.	beh.	
--	265-05.179	Vulschijf 17,1x24x0,8	n.	beh.	
12	277-03.115	Facettenschijf 15,1x24x1,5x2	1	1	1
--	261-05.144	Vulschijf 15,1x24x0,1	n.	beh.	
--	261-05.137	Vulschijf 15,1x24x0,2	n.	beh.	
--	261-05.138	Vulschijf 15,1x24x0,5	n.	beh.	
--	261-05.132	Vulschijf 15,1x24x0,8	n.	beh.	
13	258-03.600	Zuigerpen naaldlager 12x15x14,8	1	1	1
14	M 121 z 605	Zuigerpen \emptyset 12	1	1	1

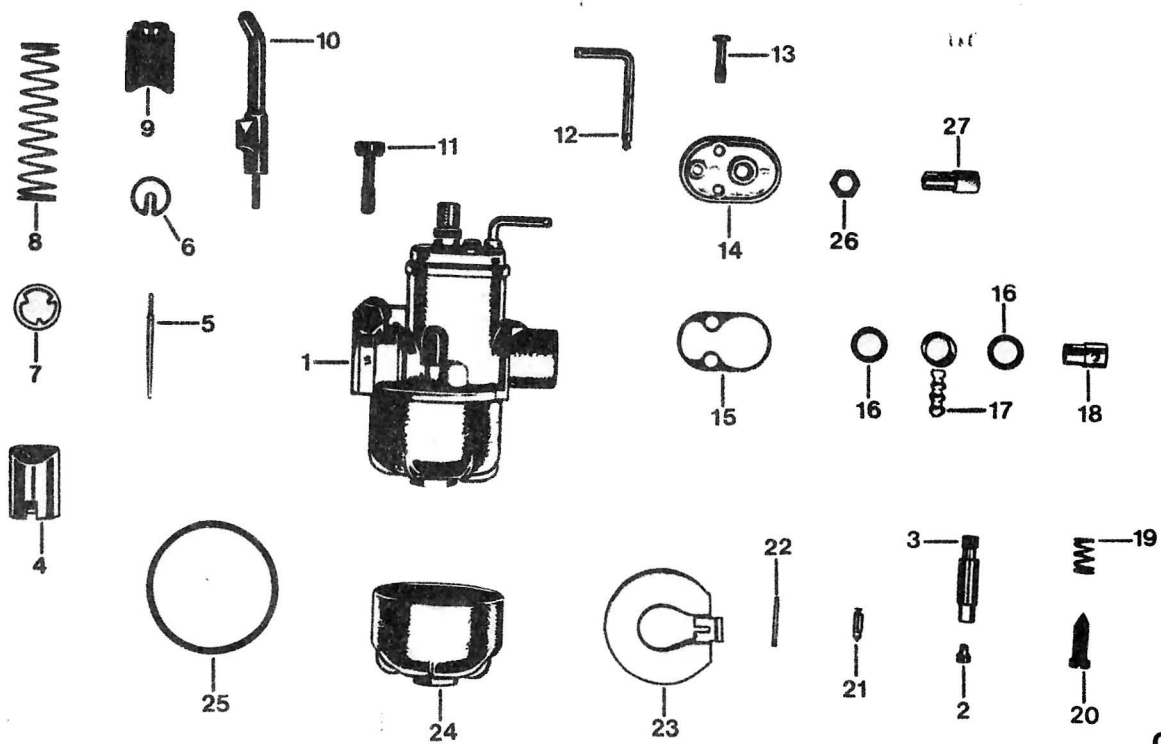

04.278.1

Afb.	Bestelnummer	Omschrijving	CS
1	266-04.731	Carburateur kpl. 1/10/139	1
2	276-04.924	Hoofdsproeier no. 58	n.beh.
-	248-04.908	Hoofdsproeier no. 60	1
-	248-04.900	Hoofdsproeier no. 62	n.beh.
3	248-04.911	Naaldsproeier no. 2,12	n.beh.
-	266-04.910	Naaldsproeier no. 2,15	1
-	278-04.904	Naaldsproeier no. 2,17	n.beh.
4	284-04.905	Gasschuiif	1
5	267-04.903	Sproeiernaald	1
6	265-04.907	Sproeiernaaldhouder	1
7	265-04.912	Plaatje	1
8	265-04.909	Gasschuiifveer	1
9	265-04.908	Startschuiif	1
10	248-04.917	Tickler	1
11	266-04.909	Klemschroef	1
12	249-04.901	Drukstift	1
13	267-04.960	Boutje	2
14	265-04.900	Mengkamerdeksel	1
15	265-04.910	Mengkamerdeksel-pakking	1
16	267-04.946	Afdichtring	2
17	251-04.933	Slangnippel	1
18	251-04.934	Boutje	1
19	251-04.922	Stelschroefveer	1
20	251-04.921	Luchtregelschroef	1
21	267-04.961	Vlotternaald	1
22	267-04.941	Scharnierstift	1
23	267-04.962	Vlotter	1
24	267-04.922	Vlotterkamer	1
25	267-04.947	Pakking	1
26	251-04.927	Contamoer voor stelschroef	1
27	400-17.126	Kabelstelschroef	1

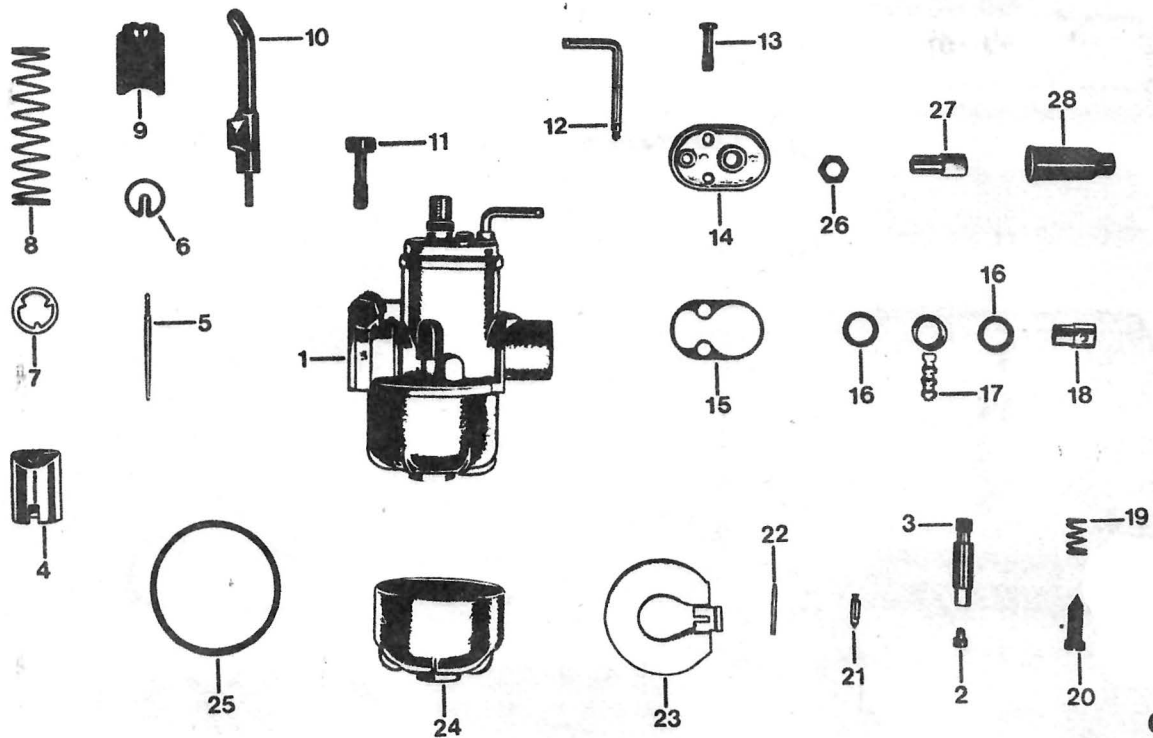

04.278.1

Afb.	Bestelnummer	Omschrijving	GTS	KS
1	280-04.713	Carburateur kpl. 1/10/140	1	1
2	248-04.909	Hoofdsproeier no. 56	n. beh.	
-	276-04.924	Hoofdsproeier no. 58	1	1
-	248-04.908	Hoofdsproeier no. 60	n. beh.	
3	248-04.911	Naaldsproeier no. 2,12	n. beh.	
-	266-04.910	Naaldsproeier no. 2,15	1	1
-	278-04.904	Naaldsproeier no. 2.17	n. beh.	
4	278-04.910	Gasschuif	1	1
5	248-04.914	Sproeiernaald	1	1
6	265-04.907	Sproeiernaaldhouder	1	1
7	265-04.912	Plaatje	1	1
8	265-04.909	Gasschuifveer	1	1
9	265-04.908	Startschuif	1	1
10	248-04.917	Tickler	1	1
11	266-04.909	Klemschroef	1	1
12	249-04.901	Drukstift	1	1
13	267-04.960	Boutje	2	2
14	265-04.900	Mengkamerdeksel	1	1
15	265-04.910	Mengkamerdeksel-pakking	1	1
16	267-04.946	Afdichtring	2	2
17	251-04.933	Slangnippel	1	1
18	251-04.934	Boutje	1	1
19	251-04.922	Stelschroefveer	1	1
20	251-04.921	Luchtregelschroef	1	1
21	267-04.961	Vlotternaald	1	1
22	267-04.941	Scharnierstift	1	1
23	267-04.962	Vlotter	1	1
24	267-04.922	Vlotterkamer	1	1
25	267-04.947	Pakking	1	1
26	251-04.927	Contamoer voor stelschroef	1	1
27	400-17.126	Kabelstelschroef	1	1
28	517-17.111	Rubber tule	1	1

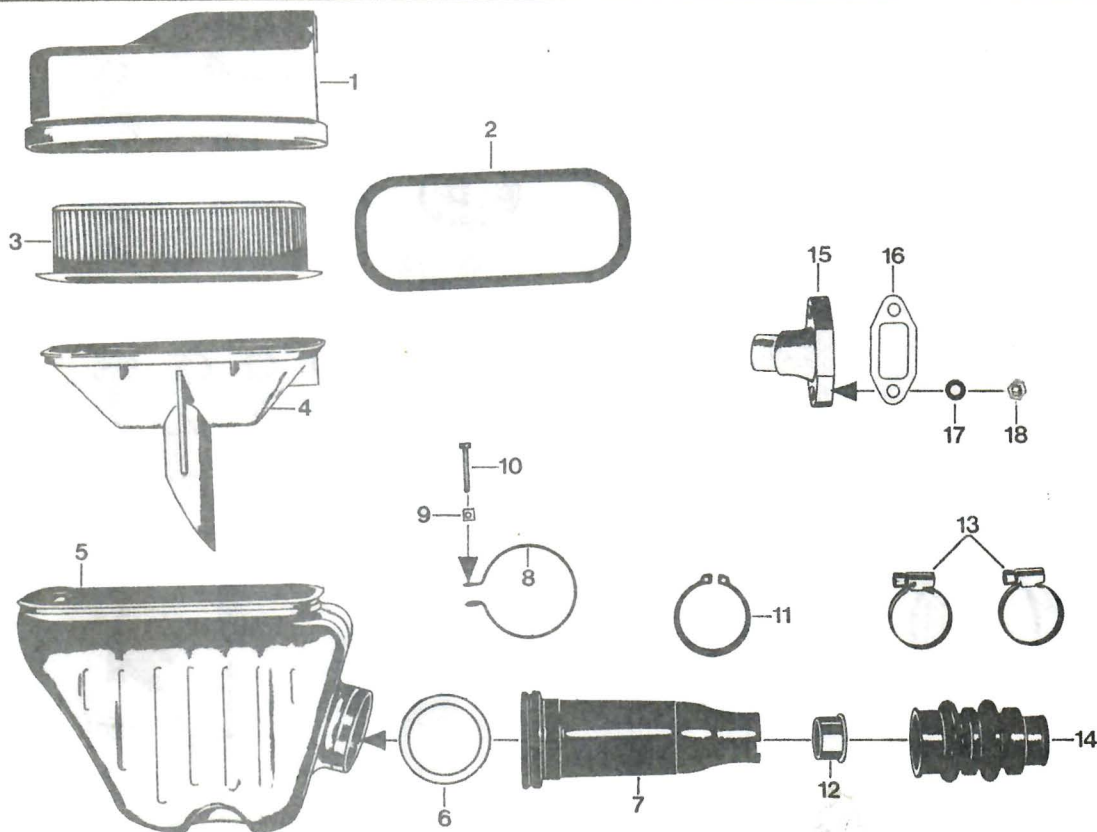

04.278.2

Afb.	Bestelnummer	Omschrijving	CS	GTS	KS
1	517-10.152	Kap voor geruisdemper	1	1	1
2	517-10.142	Afdichtring	1	1	1
3	517-10.604	Microfilter	1	1	1
4	517-10.133	Aanzuigtrechter	1	1	1
5	529-10.130	Geruisdemper	1	1	1
6	517-10.123	Versterkingsring	1	1	1
7	529-10.137	Luchttrechter	1	1	1
8	517-10.131	Spanveer	1	1	1
9	DIN 562 M 4	Moer	1	1	1
10	DIN 84 AM 4x25	Bout	1	1	1
11	DIN 471 40x1,75	Borgveer	1	1	1
12	280-04.107	Aanzuigbus \varnothing 24,5	1	1	1
13	DIN 3017 LA 20-32	Klemring	3	2	2
13	DIN 3017 LA 25-40	Klemring	-	1	1
14	278-04.112	Harmonicarubber	1	-	-
14	280-04.106	Harmonicarubber	-	1	1
15	266-04.108	Aanzuigflens	1	-	-
15	280-04.104	Aanzuigflens	-	1	1
16	267-04.113	Aanzuigpakking	1	-	-
16	283-04.111	Aanzuigpakking	-	1	1
17	DIN 433 6,4	Ringethe	2	2	2
18	DIN 934 M 6	Moer	2	2	2

Schakelhevel - schakelvork - trapas

CS

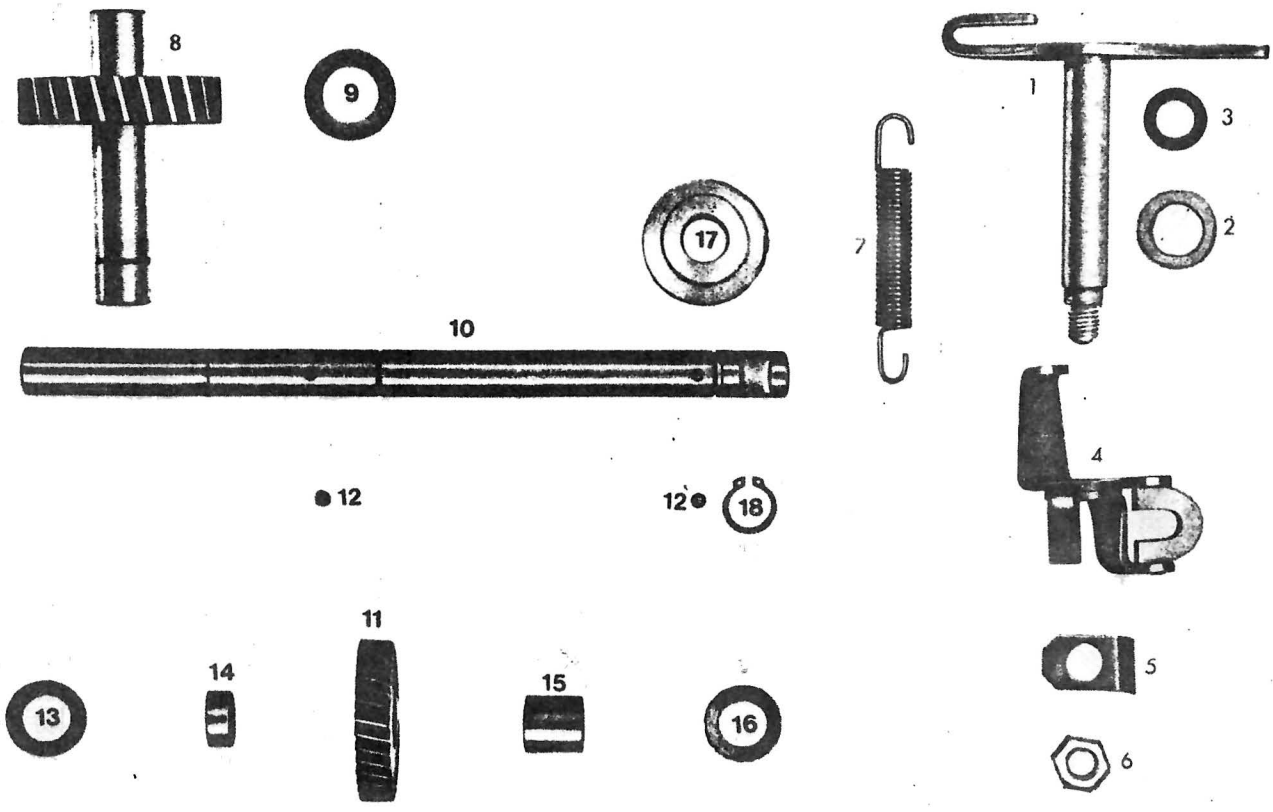

Afb.	Bestelnummer	Omschrijving	CS
1	265-05.612	Schakelhevel	1
2	278-05.165	Vulschijf 9,2x18,0x1,5	1
-	265-05.156	Vulschijf 9,2x18,1x1,5	1
3	265-05.252	Ring	1
4	265-05.613	Schakelvork	1
5	265-05.184	Borgplaatje	1
6	DIN 934 M 7	Moer	1
7	265-05.118	Trekveer	1
8	265-05.625	Tussenas met tandwiel kpl.	1
9	261-05.242	Vulschijf 18x20x0,5	1
-	261-05.241	Vulschijf 18x20x0,2	n.beh.
10	266-05.190	Trapas kaal	1
11	265-05.218	Trapastandwiel 35 tanden	1
12	DIN 5401 Ø 5	Kogel	4
13	265-05.241	Vulschijf 16,2x28x1,5	2
--	265-05.243	Vulschijf 16,2x28x0,2	n.beh.
--	265-05.244	Vulschijf 16,2x28x0,1	n.beh.
14	265-05.220	Afstandbus 16,2x20x8,5	1
15	265-05.221	Afstandbus 16,2x20x19,8	1
16	265-05.242	Vulschijf 16,2x20x0,5	n.beh.
17	266-05.191	Meenemer	1
18	DIN 471 12x1	Borgveer	1

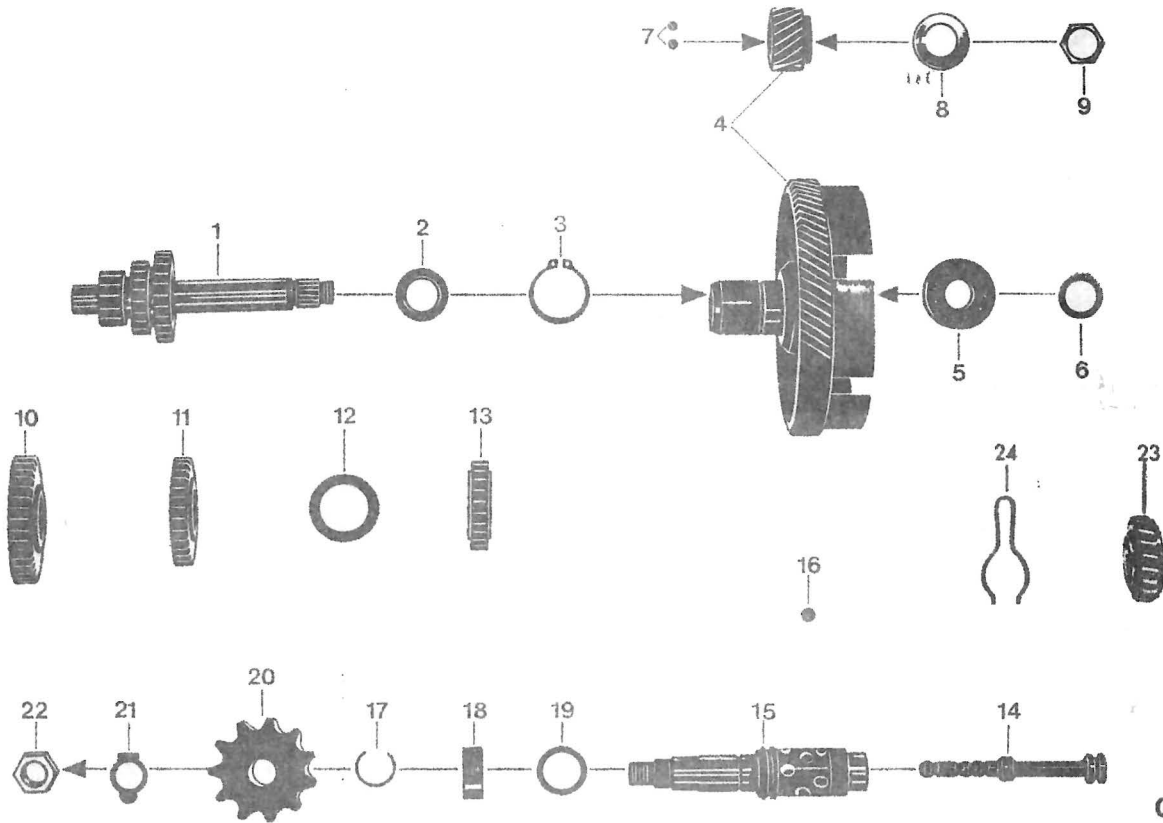

05.278.1

Afb.	Bestelnummer	Omschrijving	CS
1	266-05.157	Hoofdas	1
2	276-05.108	Vulschijf 15,1x17,8x24x1,0	n.beh.
-	276-05.110	Vulschijf 15,1x17,8x24x1,5	n.beh.
3	DIN 471 25x1,2	Borgveer	1
4	283-05.900	Koppelingshuis	1
5	DIN 625 6002	Kogellager 15x32x9	1
6	M 1301 z 459	Vulschijf 15,1x21x0,1	n.beh.
-	M 1301 z 451	Vulschijf 15,1x21x0,2	n.beh.
-	M 1301 z 452	Vulschijf 15,1x21x0,5	n.beh.
-	M 1301 z 459	Vulschijf 15,1x21x0,8	n.beh.
7	DIN 5401 ϕ 5	Kogel	2
8	265-05.122	Vulschijf 15,2x25x0,8	1
9	265-05.123	Moer M 15x1 (SW 19)	1
10	266-05.110	Tandwiel 1e versnelling, 37 t.	1
11	266-05.113	Tandwiel 2e versnelling, 31 t.	1
12	265-05.256	Vulschijf 22,1x32x0,1	n.beh.
--	265-05.255	Vulschijf 22,1x32x0,2	n.beh.
13	266-05.263	Tandwiel 3e versnelling, 25 t.	1
14	265-05.105	Trekspie	1
15	265-05.101	Schakelas	1
16	278-05.101	Kogel ϕ 7	12
17	265-05.181	Borgring	1
18	267-05.549	Afstandbus	1
19	265-05.176	Vulschijf 17,1x23x0,2	n.beh.
--	265-05.177	Vulschijf 17,1x23x0,1	n.beh.
20	265-05.275	Kettingwiel 11 tanden	1
21	265-05.183	Borgplaatje voor kettingwiel	1
22	423-15.460	Moer M 12x1	1
23	265-05.900	Tandwiel met bus	1
24	265-05.164	Remveer	1

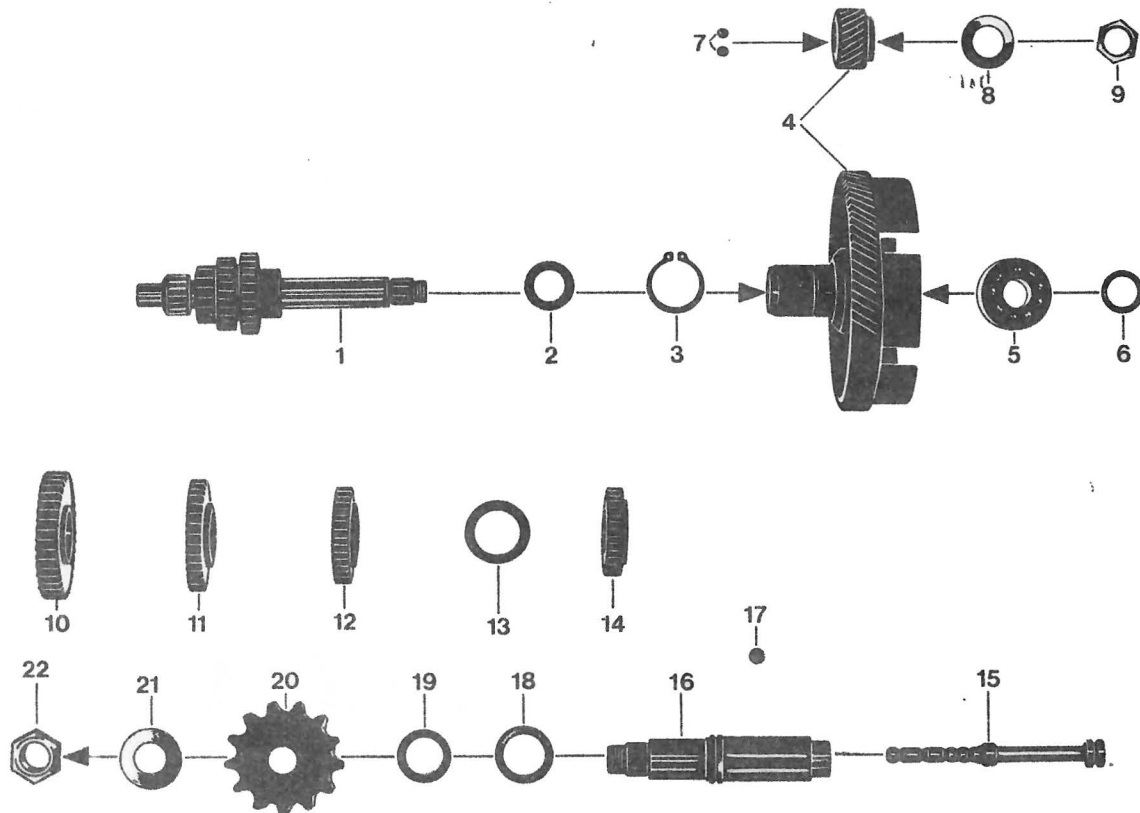

05.280.1

Afb.	Bestelnummer	Omschrijving	GTS	KS
1	276-05.613	Hoofdas	1	1
2	261-05.132	Vulschijf 15,1x24x0,8	n.	beh.
-	261-05.133	Vulschijf 15,1x24x1,0	n.	beh.
3	DIN 471 25x1,2	Borgveer	1	1
4	283-05.900	Koppelingshuis	1	1
5	DIN 625 6002	Kogellager 15x32x9	1	1
6	M 1301 z 459	Vulschijf 15,1x21x0,1	n.	beh.
-	M 1301 z 451	Vulschijf 15,1x21x0,2	n.	beh.
-	M 1301 z 452	Vulschijf 15,1x21x0,5	n.	beh.
-	M 1301 z 450	Vulschijf 15,1x21x0,8	n.	beh.
7	DIN 5401 ϕ 5	Kogel	2	2
8	265-05.122	Borgschijf 15,2x25x0,8	1	1
9	265-05.123	Moer M 15x1 (SW 19)	1	1
10	276-05.140	Tandwiel 1e versnelling, 40 t.	1	1
11	277-05.141	Tandwiel 2e versnelling, 35 t.	1	1
12	276-05.142	Tandwiel 3e versnelling, 30 t.	1	1
13	265-05.256	Vulschijf 22,1x32x0,1	n.	beh.
--	265-05.255	Vulschijf 22,1x32x0,2	n.	beh.
--	265-05.257	Vulschijf 22,1x32x0,3	n.	beh.
14	276-05.146	Tandwiel 4e versnelling, 27 t.	1	1
15	276-05.148	Trekspie	1	1
16	276-05.900	Schakelas	1	1
17	278-05.101	Kogel ϕ 7	16	16
18	267-05.310	Vulschijf 20,2x28x0,1	n.	beh.
--	278-01.129	Vulschijf 20,2x28x0,2	n.	beh.
--	278-01.130	Vulschijf 20,2x28x0,5	n.	beh.
19	277-05.130	Afstandbus 20,1x25x4,3	1	1
20	276-05.218	Kettingwiel 13 tanden	1	1
21	276-05.198	Vulschijf 15,2x20x0,75	1	1
22	276-05.119	Moer M 15x1	1	1

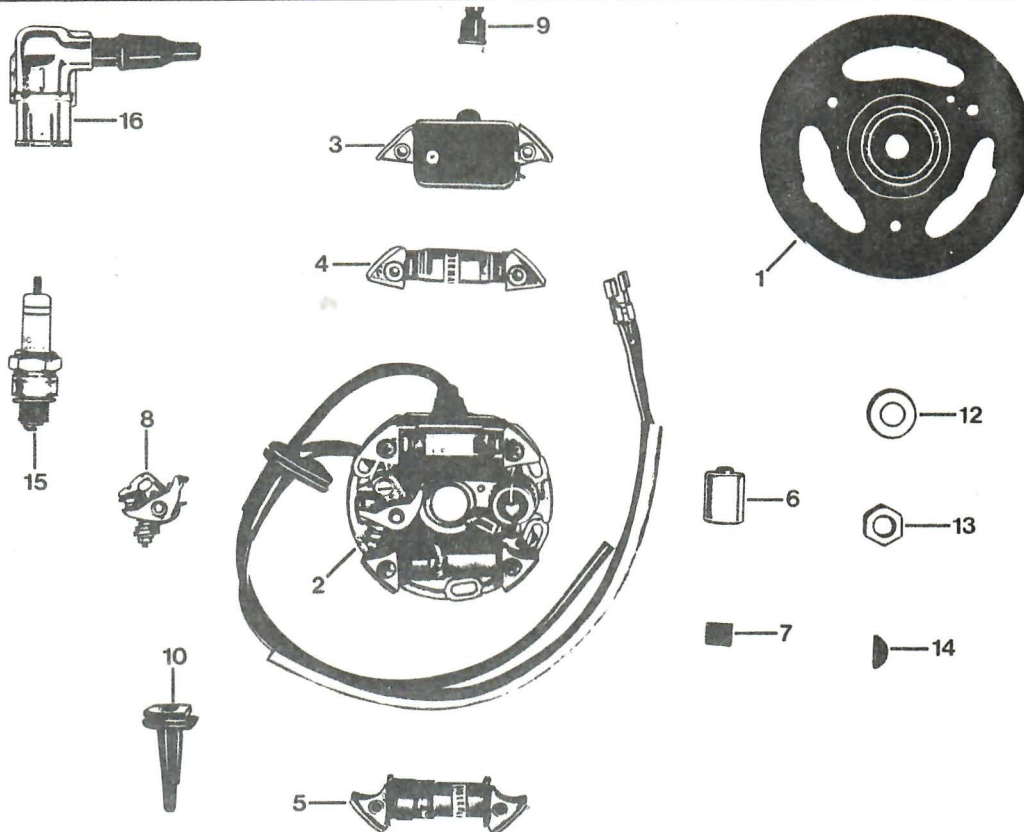

07.278.1

Afb.	Bestelnummer	Omschrijving	CS
-	280-07.707	Vliegwiel kpl. 6 V, 19-5 W	1
1	265-07.915	Vliegwiel kaal	1
2	280-07.900	Ankerplaat kpl.	1
3	265-07.909	Ontstekingspoel	1
4	265-07.910	Stoplichtspoel	1
5	265-07.926	Lichtspoel	1
6	266-07.903	Kondensator	1
7	265-07.919	Smeervilt	1
8	265-07.930	Kontaktset	1
9	285-07.144	Rubber tule	1
10	265-07.100	Kabeltule	1
12	DIN 125 A 10,5	Ring	1
13	DIN 934 M 10x1	Vliegwielmoer	1
14	DIN 6888 3x3,7	Halvemaan-spie	1
15	265-07.101	Bougie W 175	1
16	247-07.703	Ontstorningsdop	1
--	DIN 46247 6,3x1	Steckhülse	3
--	DIN 84 AM 4x16	Bout voor ankerplaat	2

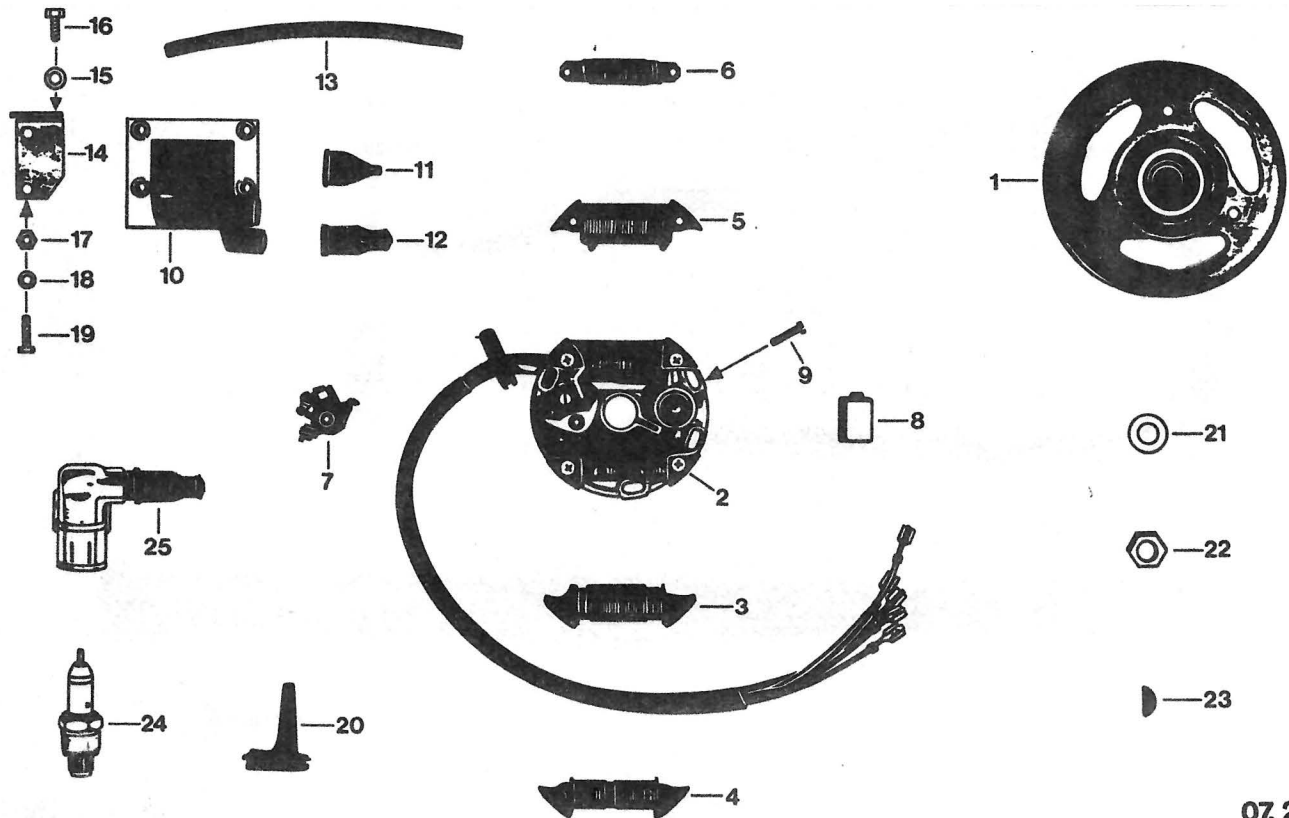

07.278.2

Afb.	Bestelnummer	Omschrijving	GTS	KS
1-8	280-07.709	Vliegwiel kpl. 6 V, 33 W	1	1
1	278-07.900	Vliegwiel kaal	1	1
2	278-07.906	Ankerplaat kpl. met kabel	1	1
3	278-07.905	Generatoranker	1	1
4	278-07.902	Generatoranker 10 W	1	1
5	278-07.904	Generatoranker 15/5 W	1	1
6	278-07.903	Generatoranker 3 W	1	1
7	265-07.930	Kontaktset	1	1
8	266-07.903	Kondensator	1	1
9	DIN 84 AM 4x16	Bout	2	2
10	283-07.702	Ontstekingspoel	1	1
11	517-16.108	Kabeltule	2	2
12	282-07.101	Rubber tule	2	2
13	282-07.104	Zündkabel	1	1
14	517-10.141	Plaat	1	1
15	DIN 127 B 6	Veerring	1	1
16	DIN 933 M 6x12	Bout	1	1
17	DIN 934 M 5	Moer	2	2
18	DIN 127 B 5	Veerring	2	2
19	DIN 933 M 5x22	Bout	2	2
20	283-07.100	Kabeltule	1	1
21	DIN 125 A 10,5	Vulschijf	1	1
22	DIN 934 M 10x1	Vliegwielmoer	1	1
23	DIN 6888 3x3,7	Halvemaan-spie	1	1
24	265-07.101	Bougie W 175	1	1
25	284-07.715	Ontstorningsdop	1	1
--	DIN 46247 6,3x1	Steckhülse	5	5

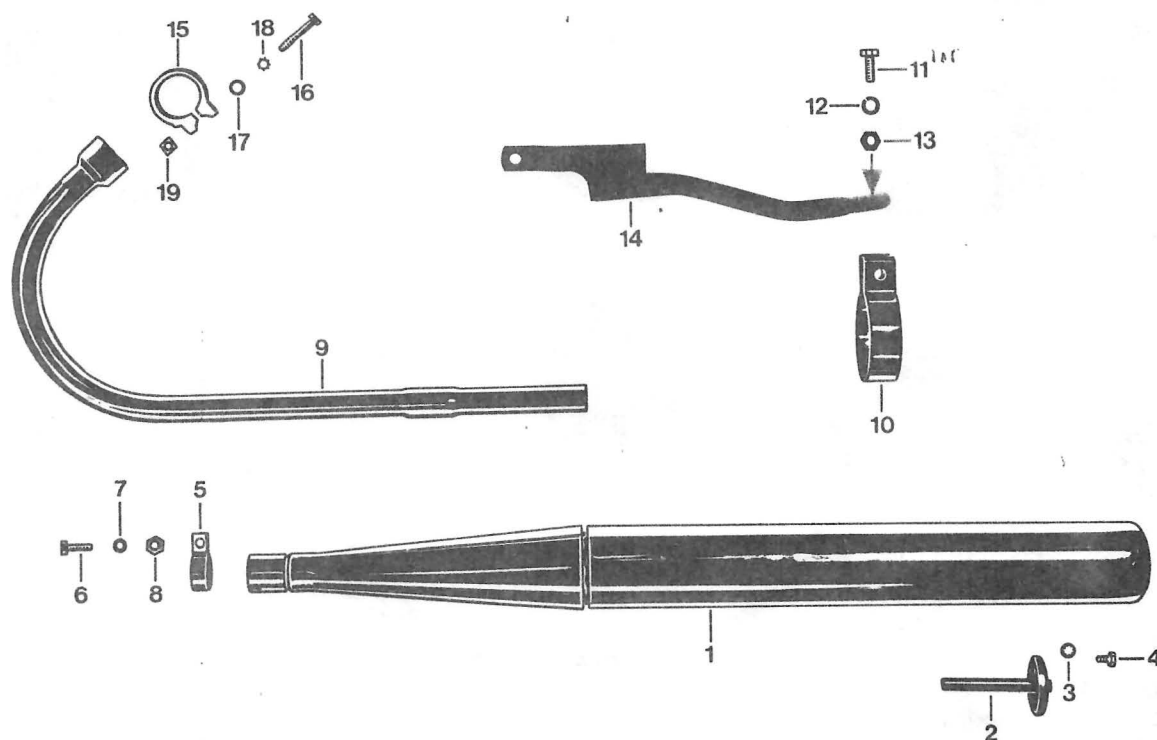

22.529.1

Afb.	Bestelnummer	Omschrijving	CS	GTS	KS
1	529-22.701	Uitlaatdemper	1	1	1
2	529-22.104	Binnendemper	1	1	1
3	DIN 6797 J 6,4	Vulschijf	1	1	1
4	DIN 933 M 6x10	Bout	1	1	1
5	517-22.173	Middenklem \varnothing 30	1	1	1
6	DIN 933 M 6x20	Bout	1	1	1
7	DIN 127 B 6	Veerring	1	1	1
8	DIN 934 M 6	Moer	1	1	1
9	529-22.105	Uitlaatbocht	1	-	-
9	517-22.171	Uitlaatbocht	-	1	1
10	517-22.169	Demperklem	1	1	1
11	DIN 933 M 8x25	Bout	1	1	1
12	DIN 127 B 8	Veerring	1	1	1
13	DIN 934 M 8	Moer	1	1	1
14	529-22.600	Ophangbeugel	1	1	1
15	441-22.104	Cylinderklem	1	1	1
16	DIN 931 M 6x35	Bout	1	1	1
17	DIN 125 A 6,4	Vulschijf	1	1	1
18	DIN 6797 A 6,4	Vulschijf	1	1	1
19	DIN 557 M 6	Moer	1	1	1

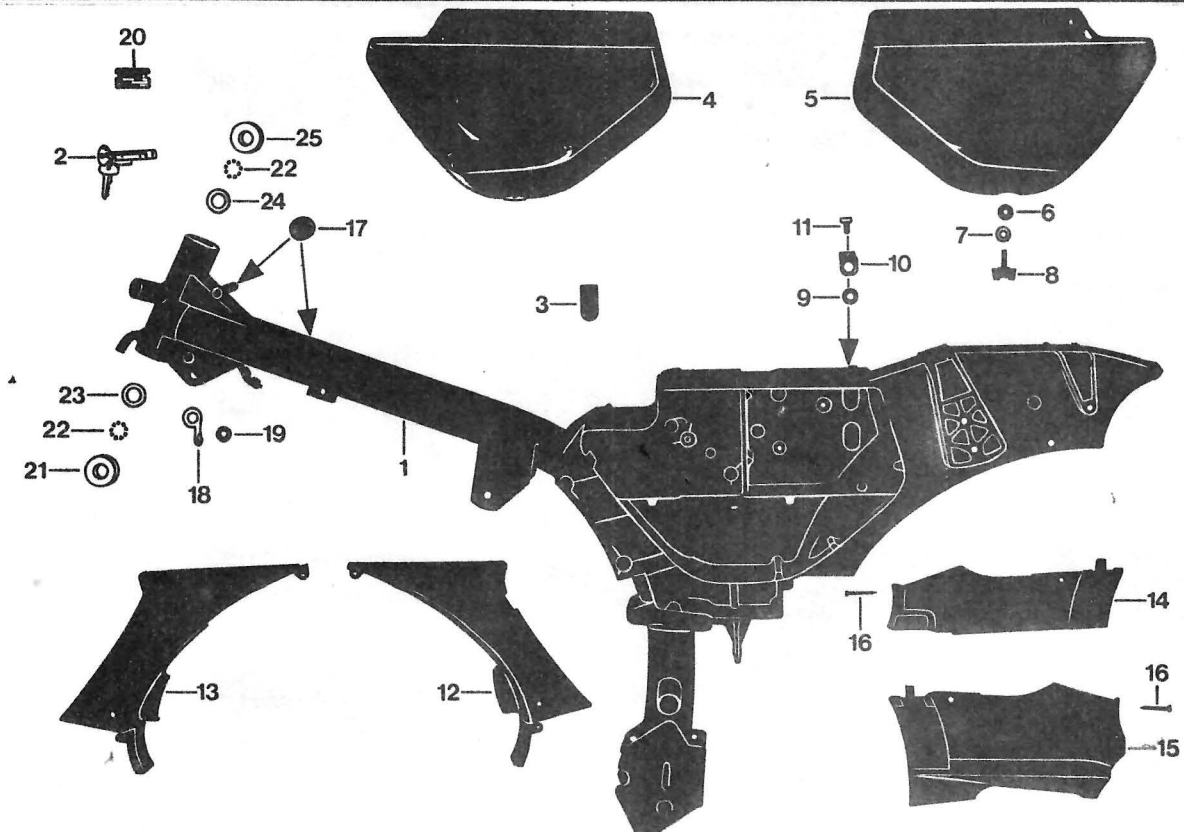

10.529.1

Afb.	Bestelnummer	Omschrijving	CS	GTS	KS
1	529-10.903	Frame met stuurslot	1	1	1
2	517-10.713	Stuurslot	1	1	1
3	284-07.132	Kabeltule	1	1	1
4	529-10.900 <u>kleur</u>	Luchtfilterdeksel) zonder	1	1	1
5	529-10.901 <u>kleur</u>	Gereedschapdeksel) transfer	1	1	1
-	529-10.119	Transfer "CS 50"	2	-	-
-	529-10.118	Transfer "GTS 50"	-	2	-
-	529-10.122	Transfer "KS 50"	-	-	2
6	521-10.107	Vulschijf 6,2x12x1	2	2	2
7	400-20.106	Vulschijf 6,4x14x1,5	2	2	2
8	529-10.146	Vleugelmoer	2	2	2
9	529-10.166	Rubber tule \varnothing 8, 17 mm lg.	4	4	4
10	529-10.164	Borgplaat	4	4	4
11	DIN 933 M 6x12	Bout	4	4	4
12	529-10.152	Framebeplating voor L.	1	1	1
13	529-10.153	Framebeplating voor R.	1	1	1
--	DIN 84 AM 5x12	Bout	8	8	8
--	DIN 7971 B3,5x13	Parkerschroef	1	1	1
14	529-10.155	Framebeplating L.	1	1	1
15	529-10.154	Framebeplating R.	1	-	-
15	529-10.151	Framebeplating R.	-	1	1
16	DIN 7971 B 4,2x32	Bout	2	2	2

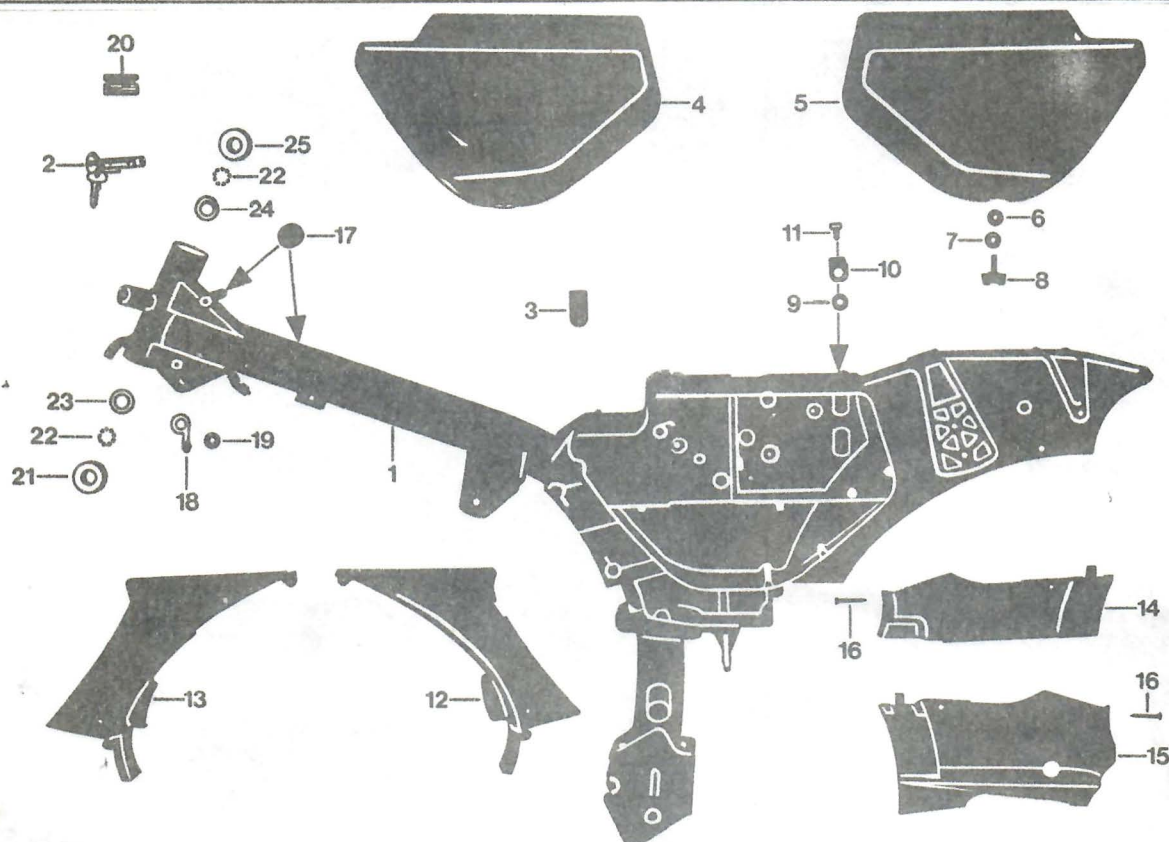

10.529.1

Afb.	Bestelnummer	Omschrijving	CS	GTS	KS
17	529-10.112	Rubber buffer	4	4	4
18	428-20.115	Kabelhouder	1	1	1
19	428-20.118	Kabeltule \varnothing 6x16	1	1	1
20	435-10.900	Typeplaatje	1	1	1
--	517-13.700	Balhoofdstel kpl. Afb. 21 - 25	1	1	1
21	517-13.104	Balhoofdconus	1	1	1
22	DIN 5401 \varnothing 6	Kogel	38	38	38
23	517-13.103	Balhoofdcup onder	1	1	1
24	517-13.102	Balhoofdcup boven	1	1	1
25	517-13.101	Stelconus	1	1	1

Motorophanging

CS GTS KS

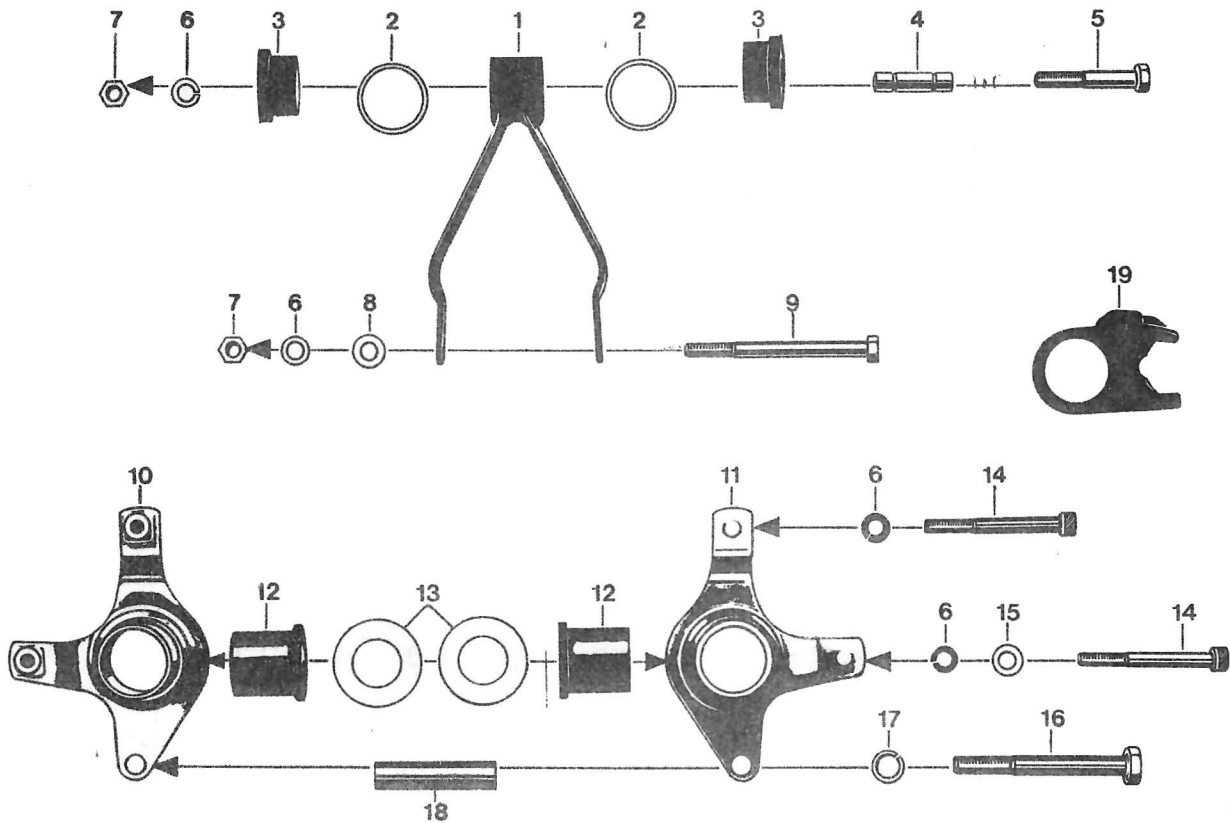

18.529.1

Afb.	Bestelnummer	Omschrijving	CS	GTS	KS
1	529-18.603	Ophangsteun	1	-	-
-	529-18.600	Ophangsteun	-	1	1
2	517-18.110	Vulschijf 30,2x37x1,5	2	2	2
3	517-18.109	Ophangrubber	2	2	2
4	428-18.108	Afstandsbus	1	1	1
5	DIN 931 M 8x55	Bout	1	1	1
6	DIN 127 B 8	Veerring	4	4	4
7	DIN 934 M 8	Moer	2	2	2
8	405-18.109	Vulschijf 8,4x16x3	1	1	1
9	DIN 931 M 8x95	Bout	1	1	1
10	529-18.601	Ophangsteun L.	1	1	1
11	529-18.602	Ophangsteun R.	1	1	1
12	529-18.107	Rubber voor ophangsteunen	2	2	2
13	529-18.104	Vulschijf 26,2x45x5	2	2	2
14	DIN 931 M 8x70	Bout	2	2	2
15	DIN 125 A 8,4	Vulschijf	1	1	1
16	DIN 931 M 10x90	Bout	1	1	1
17	DIN 127 B 10	Veerring	1	1	1
18	529-18.108	Bus	1	1	1
19	529-18.109	Geleider	1	1	1

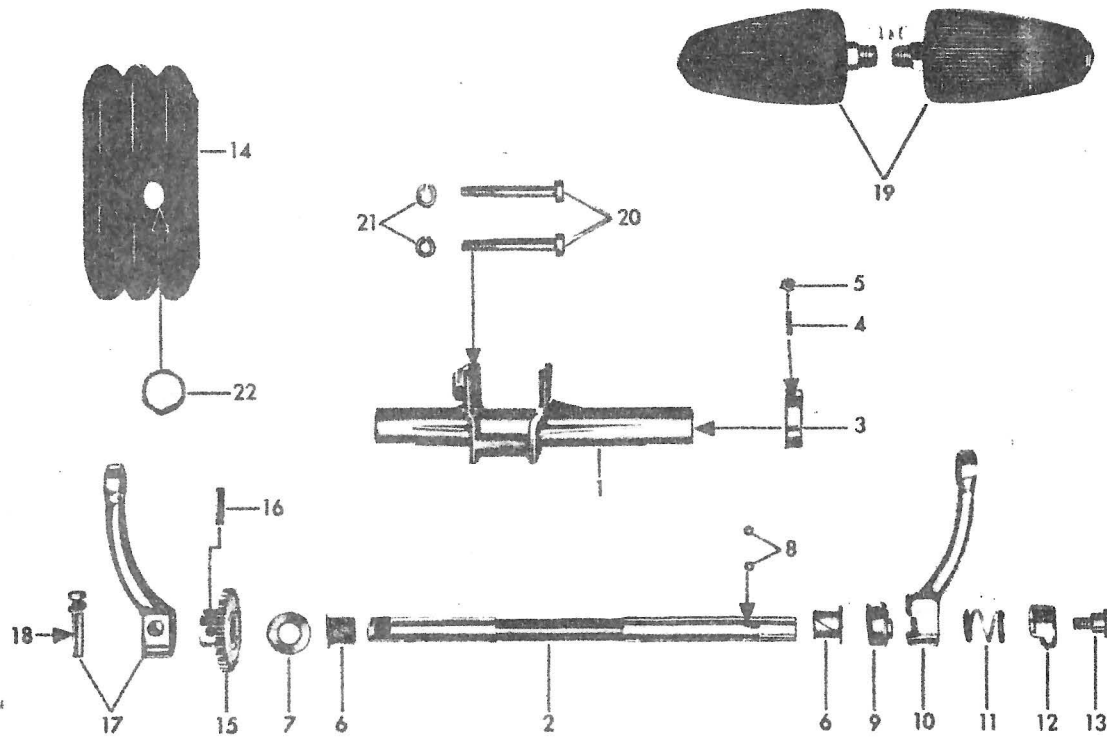

Afb.	Bestelnummer	Omschrijving	CS	GTS	KS
1	517-11.601	Trapaslager		1	1
2	517-11.116	Trapas		1	1
3	517-11.119	Excenterplaat		1	1
4	DIN 914 M 5x15	Stelbout		1	1
5	DIN 934 M 5	Moer		1	1
6	517-11.108	Glijlager		2	2
7	265-05.242	Ring		2	2
8	DIN 5401 \emptyset 5	Kogel		2	2
9	266-05.191	Meenemer	1	1	1
10	517-11.100	Krank R.	1	1	1
11	517-11.101	Drukveer	1	1	1
12	517-11.102	Kape	1	1	1
13	517-11.103	Bout	1	1	1
14	517-14.154	Kettingkast-manchet		1	1
15	517-11.600	Tandwiel 25 T.		1	1
16	DIN 1473 6x24	Borgpen		1	1
17	405-11.242	Krank L.	1	1	1
18	400-11.900	Krankspie compleet	1	1	1
19	442-11.901	Pedalen (set)	1	1	1
20	DIN 931 M 8x60	Bout		2	2
21	DIN 127 B 8	Veerring		2	2
22	517-11.120	Bus		1	1

Telescoopvoorvork

CS GTS

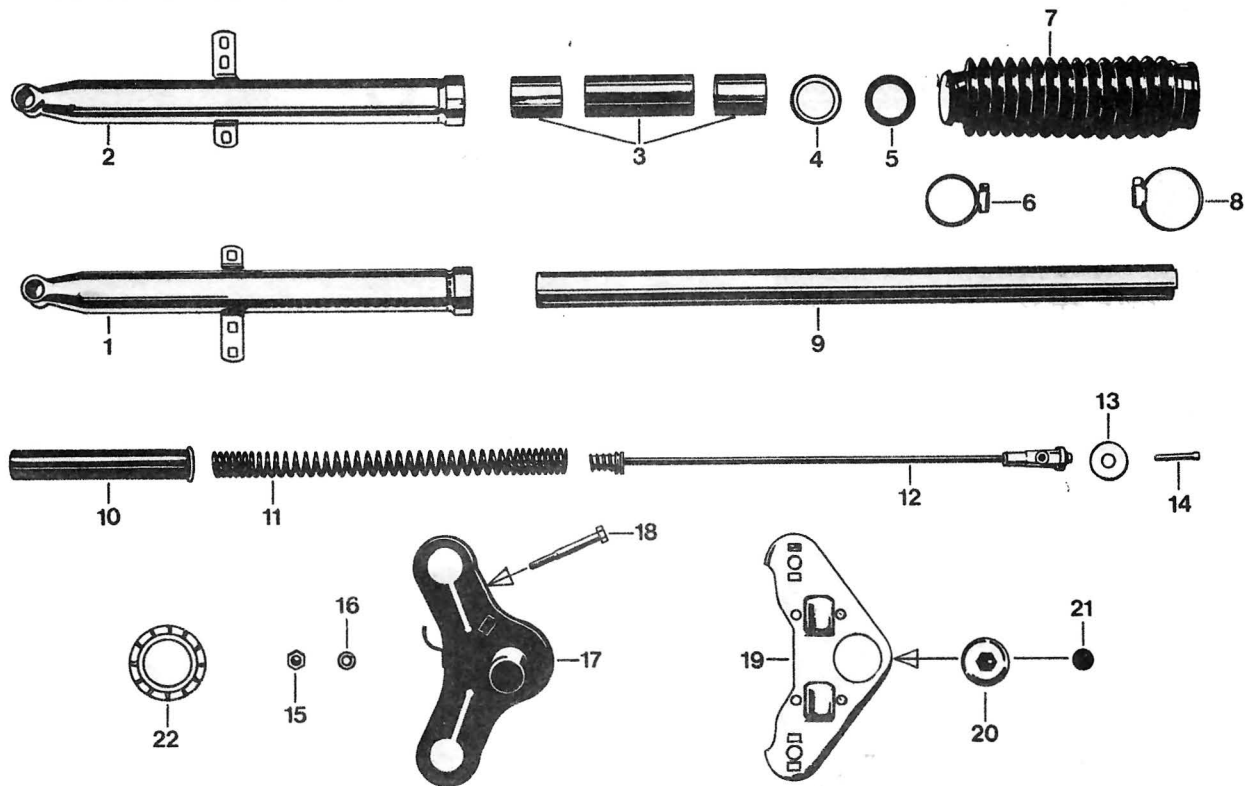

12.529.1

Afb.	Bestelnummer	Omschrijving	CS	GTS
-	529-12.900	Telescoopvoorvork kpl.	1	1
1	529-12.626	Onderpoot L.	1	1
2	529-12.628	Onderpoot R.	1	1
3	517-12.906	Glijbusset - v.twee vorkpoten-	1	1
4	517-12.140	Ring	2	2
5	520-12.142	Oliekeerring 30x40 G2/52	2	2
6	DIN 3017 LA 25-40	Klemband	2	2
7	517-12.198	Harmonicarubber	2	2
8	DIN 3017 LA 32-50	Klemband	2	2
9	529-12.623	Binnenpoot	2	2
10	517-12.131	Veergeleiderhuls	2	2
11	515-12.254	Voorvorkveer	2	2
12	529-12.612	Veerhoder	2	2
13	517-12.162	Vulschijf 8,4x32x3	2	2
14	529-12.101	Bout M 8x1x35	2	2
15	DIN 934 M 8	Moer	2	2
16	DIN 127 B 8	Veerring	2	2
17	529-12.614	Kroonstuk	1	1
18	DIN 931 M 8x60	Bout	2	2
19	529-12.600	Vorkverbinding	1	1
20	529-13.105	Balhoofdmoer	1	1
21	529-13.106	Afsluitdop	1	1
22	515-12.209	Afstandsbus	2	2

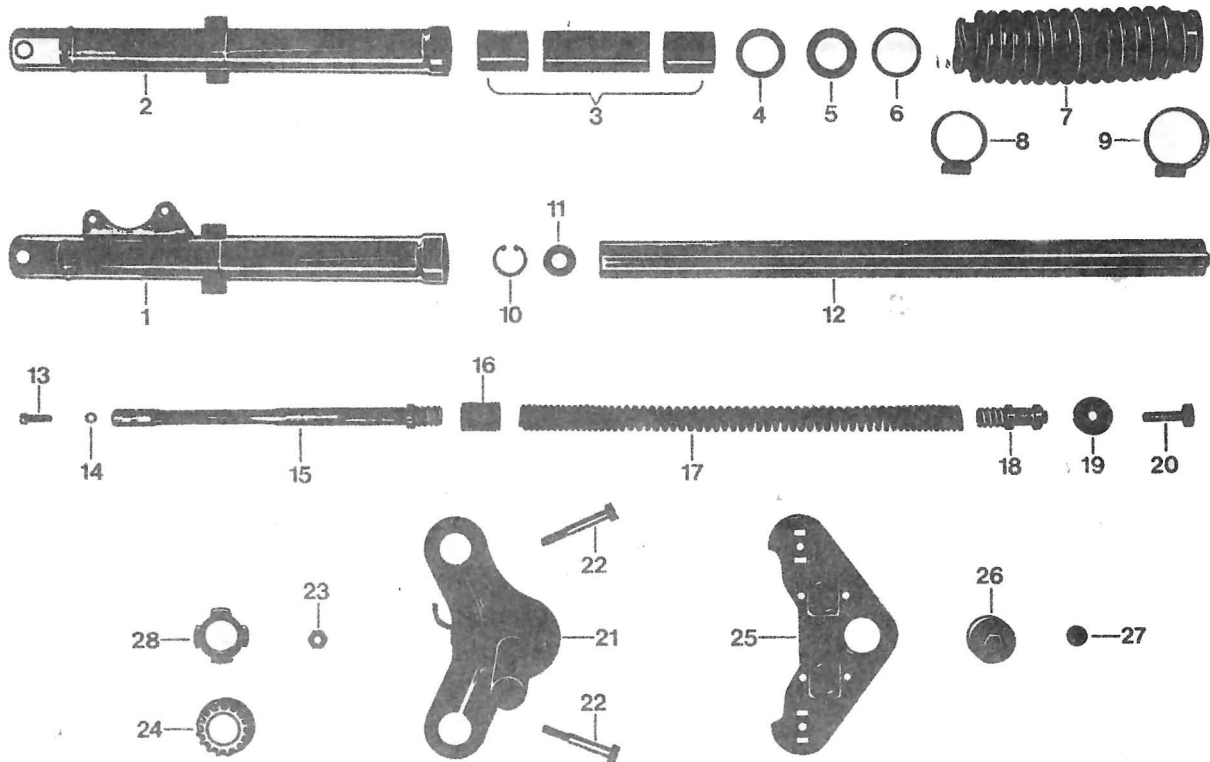

12.530.3

Afb.	Bestelnummer	Omschrijving	KS
-	530-12.902	Telescoopvoorvork kpl.	1
1	530-12.617	Onderpoot L.	1
2	530-12.618	Onderpoot R.	1
3	517-12.906	Glijbusset - v.twee vorkpoten-	1
4	517-12.140	Ring	2
5	520-12.142	Oliekeerring 30x40 G2/52	2
6	530-12.110	Afduchtring 34,5x40x1	2
7	517-12.198	Harmonicarubber	2
8	DIN 3017 LA 25-40	Klemband	2
9	DIN 3017 La 32-50	Klemband	2
10	DIN 472 26x1,2	Borgveer	2
11	530-12.103	Vulschijf 14,4x26x3	2
12	530-12.622	Binnenpoot	2
13	DIN 6912 M 6x25	Bout	2
14	520-12.271	O-Ring	2
15	530-12.101	Veerhouder	2
16	530-12.102	Veergeleiderhuls	2
17	515-12.258	Voorvorkveer	2
18	529-12.116	Veerhouder boven	2
19	517-12.162	Vulschijf 8,4x32x3	2
20	529-12.101	Bout M 8x1x35	2
21	530-12.612	Kroonstuk	1
22	DIN 931 M 8x60	Bout	2
23	DIN 934 M 8	Moer	2
24	515-12.209	Afstandsbus	2
25	529-12.600	Vorkverbinding	1
26	529-13.105	Balhoofdmoer	1
27	529-13.106	Afsluitdop	1
28	512-12.135	Rubberring	2

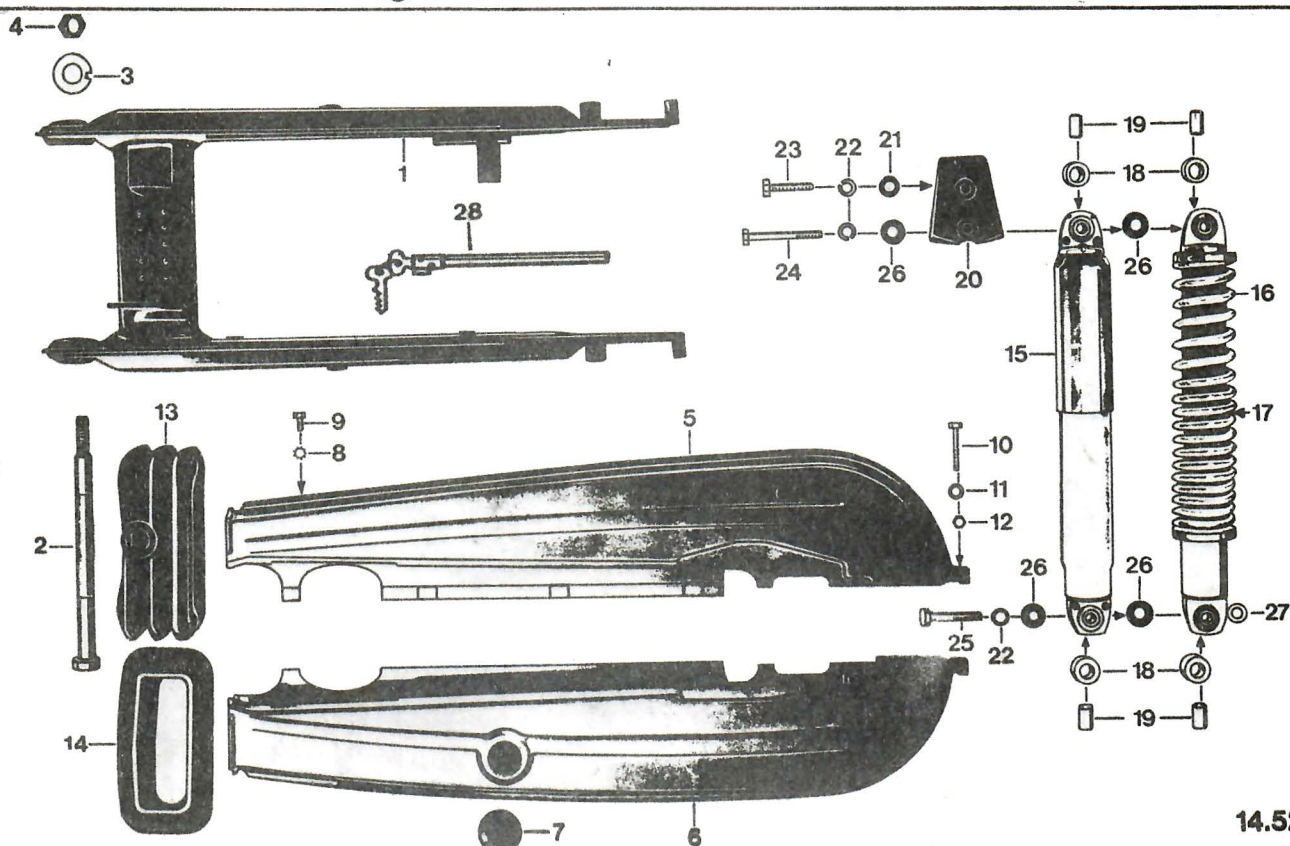

14.529.3

Afb.	Bestelnummer	Omschrijving	CS	GTS	KS
1	529-14.614	Achtervork kpl.	1	1	1
2	529-14.110	Swingarmas	1	1	1
3	DIN 432 13	Borgplaatje	1	1	1
4	DIN 936 M 12x1,5	Moer	1	1	1
5	529-14.618 <u>kleur</u>	Kettingkastdeel boven	1	1	1
6	529-14.602 <u>kleur</u>	Kettingkastdeel onder	1	1	1
7	432-14.117	Inspektierrubber	1	1	1
8	DIN 6797 A 6,4	Vulschijf	2	2	2
9	DIN 912 M 6x10	Bout	2	2	2
10	DIN 931 M 6x35	Bout	1	1	1
11	DIN 137 B 6	Veerring	1	1	1
12	DIN 934 M 6	Moer	1	1	1
13	517-14.154	Kettingkast-manchet	-	1	1
14	517-14.119	Kettingkast-manchet	1	-	-
15	529-14.702	Schokbreker compleet	2	-	-
16	529-14.701	Schokbreker compleet	-	2	2
17	517-14.145	Schokbrekerveer	-	2	2
18	433-14.129	Bus	4	4	4
19	433-14.141	Bus	4	4	4
20	529-14.100	Schokbrekerplaat	2	2	2
21	DIN 125 A 8,4	Vulschijf	2	2	2
22	DIN 127 B 8	Veerring	6	6	6
23	DIN 933 M 8x35	Bout	2	2	2
24	DIN 931 M 8x60	Bout	2	2	2
25	DIN 931 M 8x42/22	Bout	2	2	2
26	422-14.183	Sluitring	8	8	8
27	405-18.109	Vulschijf	-	2	2
28	529-10.904	Pen slot	1	1	1

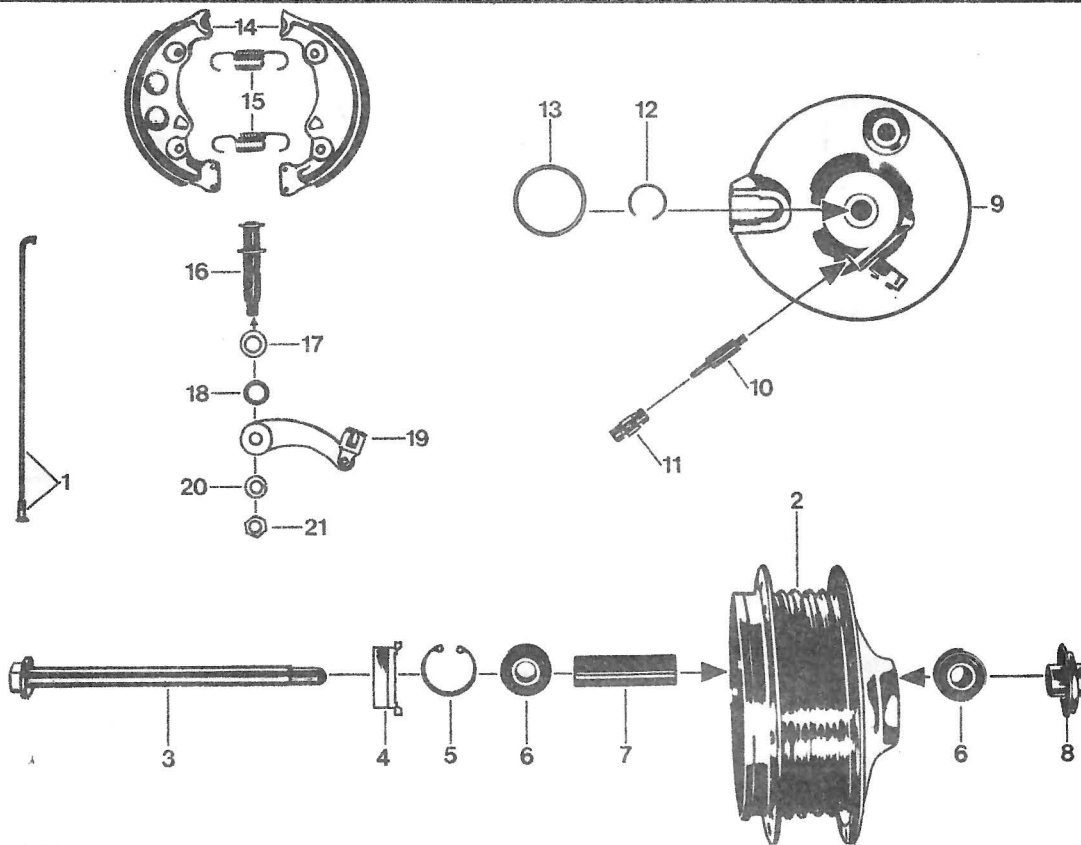

15.529.1

Afb.	Bestelnummer	Omschrijving	CS
-	441-15.710	Voorwiel, bestaande uit: velg, spaken, kale naaf met lagers	1
-	530-15.110	Buitenband 2 3/4 - 17	1
-	433-15.216	Binnenband 2 3/4 - 17	1
-	517-15.119	Velg 1,50A-17	1
1	517-15.152	Binnenspaak M3,5x181/10,8	18
1	517-15.153	Binnenspaak M3,5x181/11,3	18
2	517-15.633	Naafhuis kaal	1
3	512-15.104	Steekas	1
4	517-15.151	Tellertandwiel	1
5	DIN 472 32x1,2	Borgveer	1
6	DIN 625 6201 Z	Kogellager 12x32x10	2
7	433-15.102	Afstandsbus	1
8	517-15.634	Tussenbus	1
9	517-15.639	Remankerplaat kaal	1
10	515-15.106	Tellerasje 12 T.	1
11	515-15.100	Draadstukje voor telleraandrijving	1
12	DIN 9045 A 22	Borgring	1
13	510-15.164	Viltring	1
14	561-15.903	Remsegmenten (set)	1
15	517-15.127	Remsegmentveer	2
16	405-15.623	Remsleutel	1
17	267-05.597	Vulschijf 0,2 mm	1
18	405-15.388	O-Ring	1
19	517-15.638	Remhevel	1
20	DIN 127 B 8	Veerring	1
21	DIN 936 M 8x1	Moer	1

Alu voorwiel - naaf 150 mm ϕ
remtrommel

voor GTS,
voor CS vanaf framennr. 9 149 450

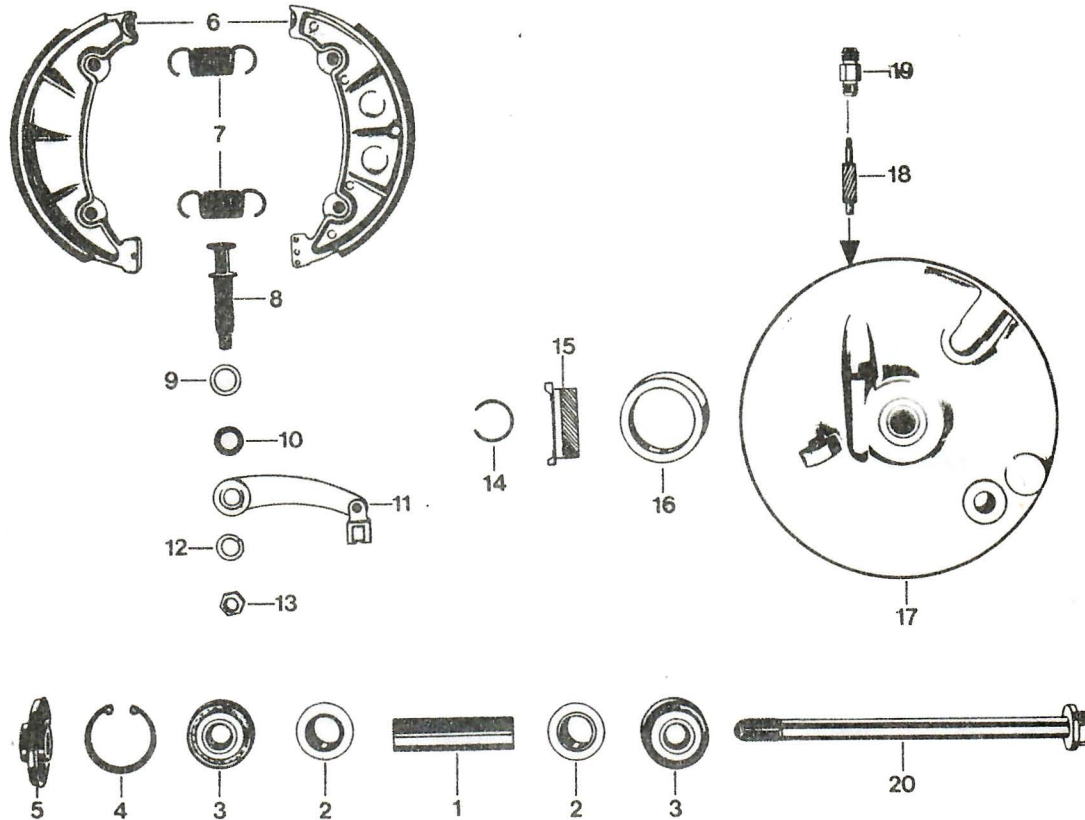

15.530.3

Afb.	Bestelnummer	Omschrijving	CS	GTS
-	530-15.606	Alu voorwiel met lagere en remtrommel	1	1
1	530-15.100	Afstandbus 67,2 mm	1	1
2	530-15.101	Vulschijf 18,4x30	2	2
3	DIN 625 6301 Z	Kogellager 12x37x12	2	2
4	DIN 472 37x1,5	Borgveer	1	1
5	530-15.603	Tussenbus	1	1
6	517-15.921	Remsegmenten (set)	1	1
7	517-15.133	Remsegmentveer	2	2
8	561-15.620	Remsleutel	1	1
9	267-05.597	Vulschijf 0,2 mm	1	1
10	405-15.388	O-Ring	1	1
11	517-15.607	Remhevel	1	1
12	DIN 127 B8	Veerring	1	1
13	DIN 936 M 8x1	Moer	1	1
14	DIN 9045 22	Borgring	1	1
15	517-15.151	Tellertandwiel	1	1
16	510-15.164	Viltring	1	1
17	517-15.605	Remankerplaat kaal	1	1
18	515-15.106	Tellerasje 12T.	1	1
19	515-15.100	Draadstukje voor telleraandrijving	1	1
20	512-15.104	Steekas	1	1
--	530-15.110	Buitenband 2 3/4 - 17	1	1
--	433-15.216	Binnenband 2 3/4 - 17	1	1

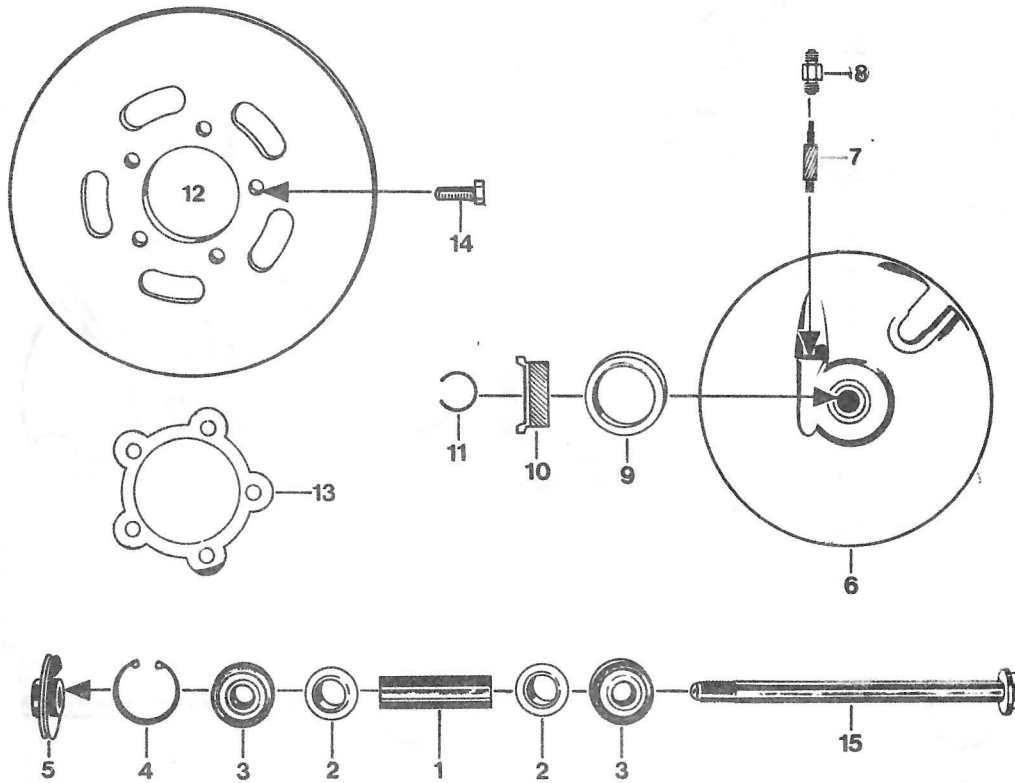

15.530.4

Afb.	Bestelnummer	Omschrijving	KS
-	530-15.608	Alu voorwiel met lagers	1
1	530-15.100	Afstandbus 67,2 mm	1
2	530-15.101	Vulschijf 18,4x30	2
3	DIN 625 6301 Z	Kogellager 12x37x12	2
4	DIN 472 37x1,5	Borgveer	1
5	530-15.603	Tussenbus	1
6	530-15.605	Remankerplaat kaal	1
7	515-15.106	Tellerasje 12 T.	1
8	515-15.100	Draadstukje voor telleraandrijving	1
9	510-15.164	Viltring	1
10	517-15.151	Tellertandwiel	1
11	DIN 9045 22	Borgring	1
12	530-15.109	Remschijf \varnothing 220 mm	1
13	530-15.108	Zekeringsplaat	1
14	DIN 933 M 8x22	Bout	5
15	512-15.104	Steekas	1
--	530-15.110	Buitenband 2 3/4-17	1
--	433-15.216	Binnenband 2 3/4-17	1

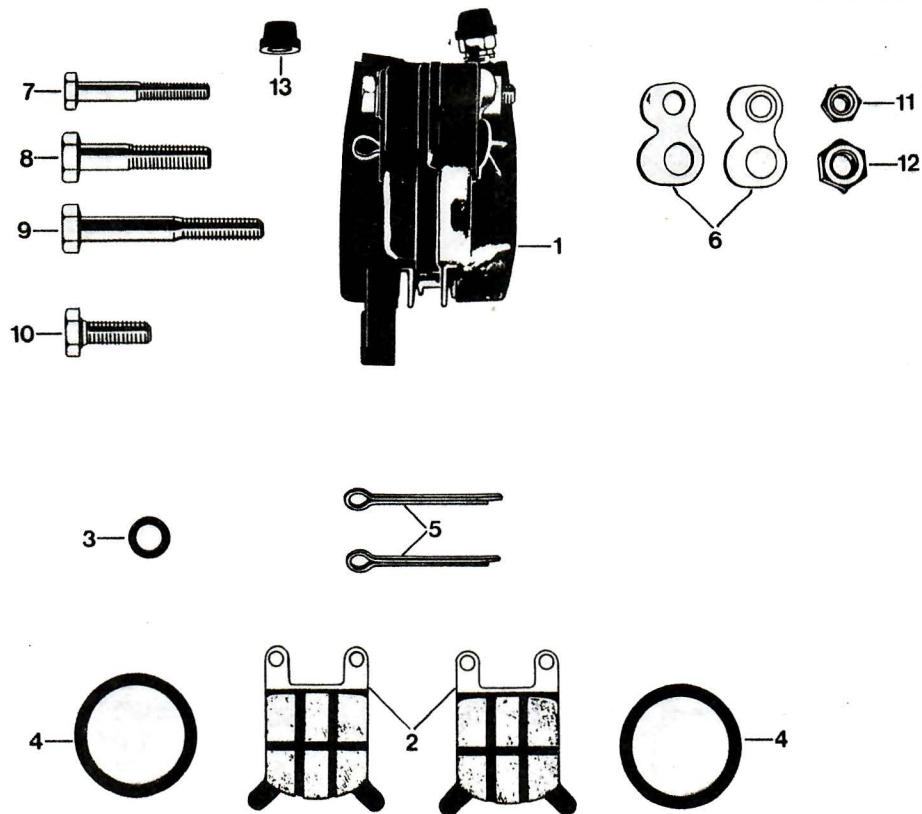

15.530.6

Afb.	Bestelnummer	Omschrijving	KS
1	530-15.707	Remklauw compleet	1
2	530-15.112	Remblokken per stel	1
3	530-15.902	Rubberring 9x2	1
4	530-15.901	Rubberring 30x3	2
5	530-15.900	Splitpen	2
6	530-15.904	Zekeringsplaat	2
7	DIN 931 M 6x40	Bout	2
8	DIN 931 M 8x40	Bout	1
9	DIN 931 M 8x55	Bout	1
10	DIN 933 M 8x25	Bout	1
11	DIN 934 M 6	Moer	2
12	DIN 934 M 8	Moer	2
13	530-15.903	Afdekplaat	1

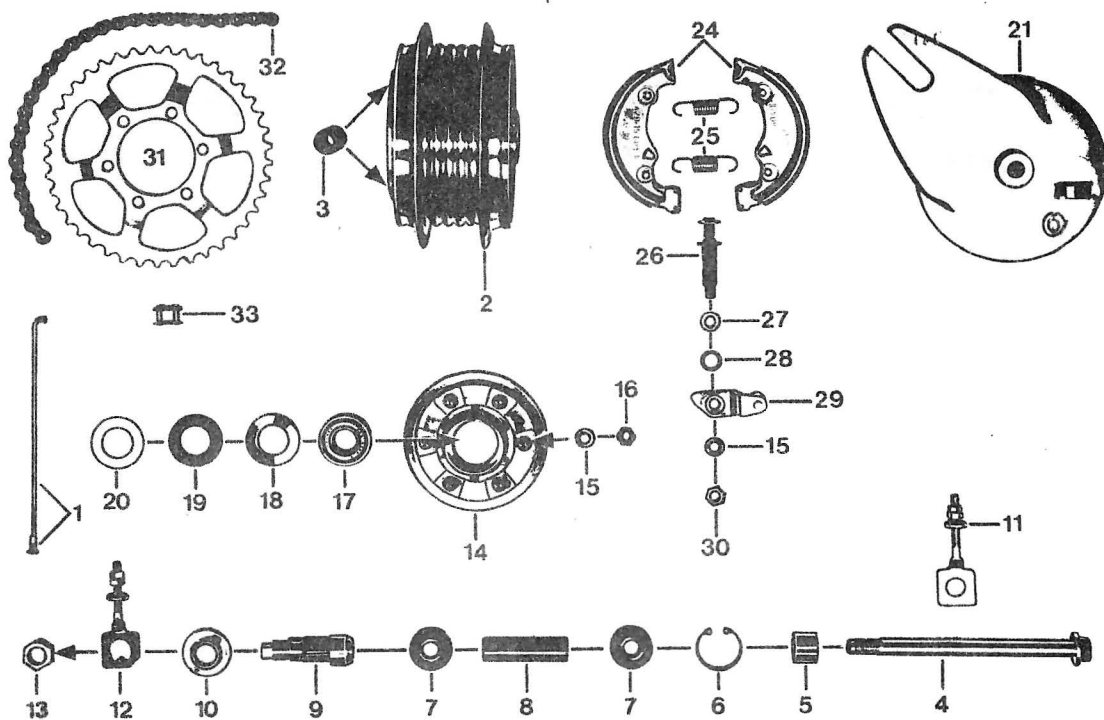

15.529.2

Afb.	Bestelnummer	Omschrijving	CS
-	441-15.707	Achterwiel, bestaande uit: velg, spaken, kale naaf met lagers	1
1	517-15.152	Binnenspaak M 3,5x181/10,8	18
-	517-15.153	Binnenspaak M 3,5x181/11,3	18
2	515-15.611	Naafhuis kaal	1
3	433-15.112	Tandwielrubber	6
4	433-15.147	Steekas	1
5	433-15.136	Afstandsring	1
6	DIN 472 32x1,2	Borgveer	1
7	DIN 625 6201 Z	Kogellager 12x32x10	2
8	433-15.102	Afstandbus	1
9	529-15.100	Draadbus	1
10	433-15.126	Afstandsring	1
11	517-15.623	Kettingspanner R.	1
12	529-15.700	Kettingspanner L.	1
13	433-15.131	Moer	1
14	561-15.626	Naafflens	1
15	DIN 127 B 8	Veerring	7
16	DIN 934 M 8	Moer	6
17	DIN 625 6203 Z	Kogellager 17x40x12	1
18	433-15.117	Afdekplaat	1
19	433-15.119	Viltring	1

Achterwiel - naaf ϕ 120 mm voor CS tot framennr. 9 149 449

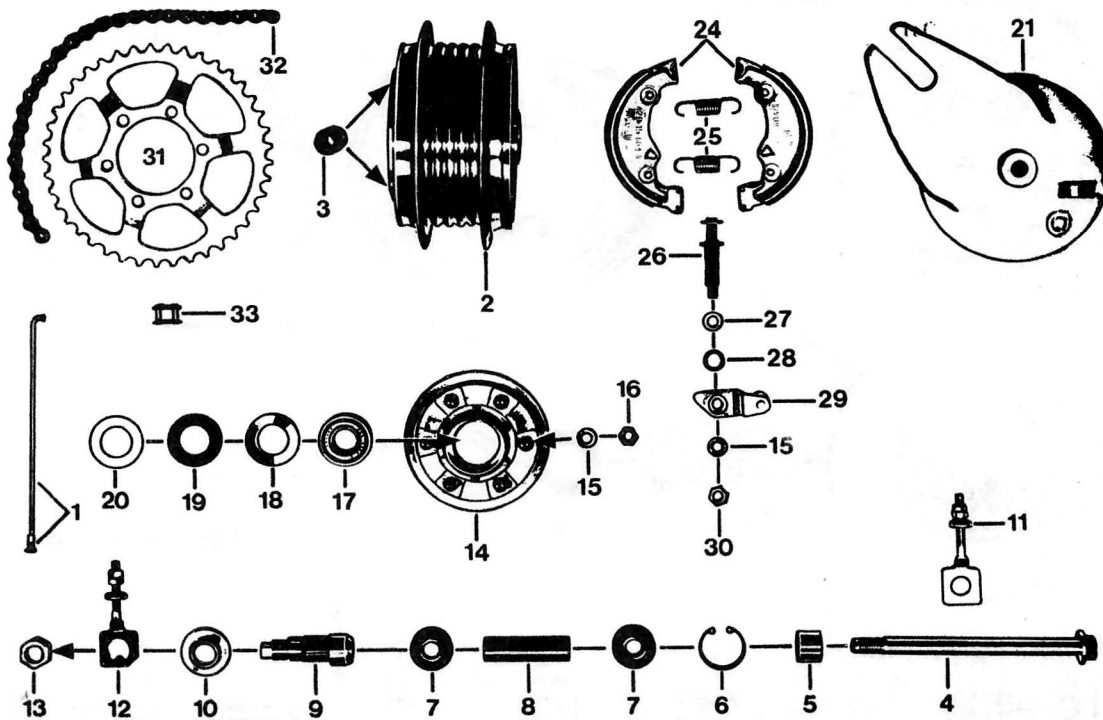

15.529.2

Afb.	Bestelnummer	Omschrijving	CS
20	433-15.121	Kap	1
21	517-15.626	Remankerplaat	1
24	561-15.903	Remsegmenten (set)	1
25	517-15.127	Remsegmentveer	2
26	405-15.623	Remsleutel	1
27	267-05.597	Vulschijf 0,2 mm	1
28	405-15.388	O-Ring	1
29	529-15.600	Remhevel	1
30	DIN 936 M 8x1	Moer	1
31	423-15.405	Kettingwiel 41 tanden	1
32	429-18.640	Ketting met slot 1/2"x3/16" 114 schakels	1
33	432-18.900	Slot voor Ketting 1/2"x3/16"	1
--	517-15.119	Velg 1.50x17	1
--	530-15.111	Buitenband 2 3/4 - 17	1
--	433-15.216	Binnenband 2 3/4 - 17	1

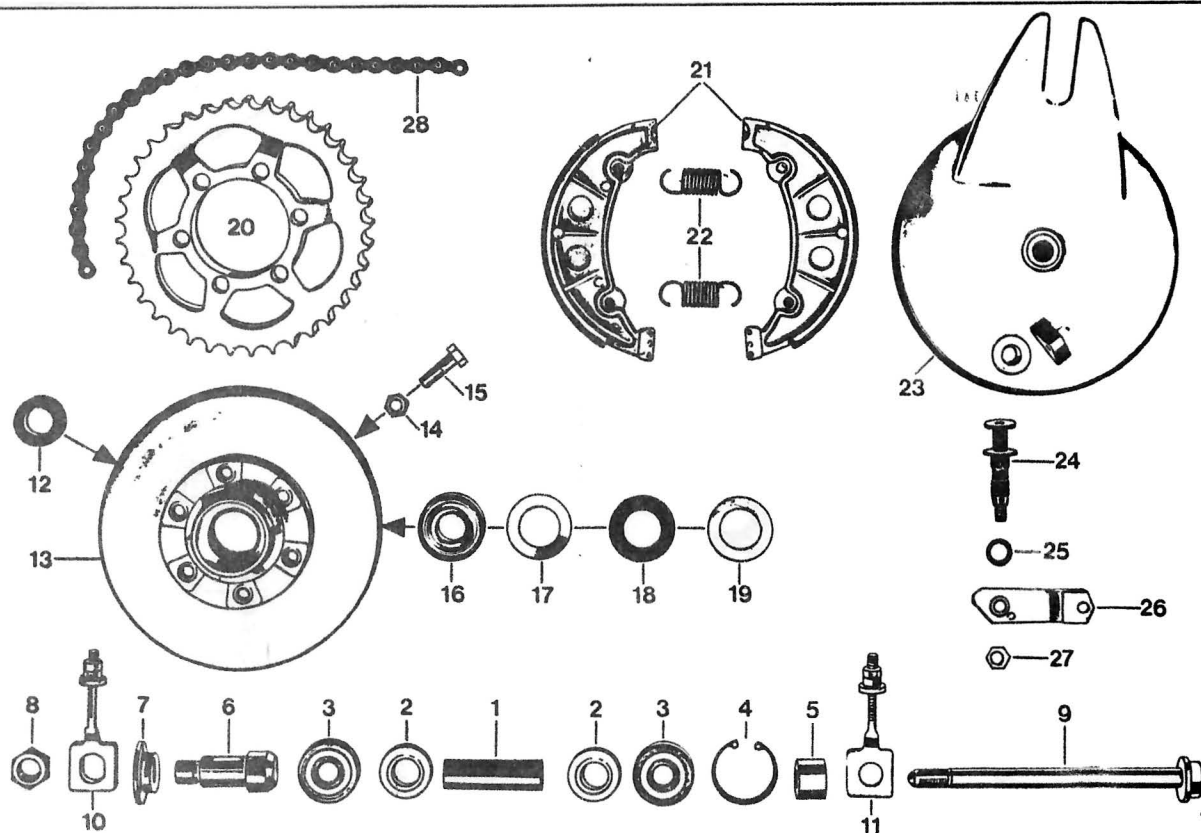

15.530.5

Afb.	Bestelnummer	Omschrijving	CS	GTS	KS
-	530-15.607	Alu-achterwiel met lagers	1	1	1
1	530-15.104	Afstandbus 59,5 mm	1	1	1
2	530-15.101	Vulschijf 18,4x30	2	2	2
3	DIN 625 6301 Z	Kogellager 12x37x12	2	2	2
4	DIN 472 37 x1,5	Borgveer	1	1	1
5	433-15.136	Afstandsring	1	1	1
6	529-15.100	Draadbus	1	1	1
7	433-15.126	Afstandsring	1	1	1
8	433-15.131	Moer	1	1	1
9	433-15.147	Steekas	1	1	1
10	529-15.700	Kettingspanner L.	1	1	1
11	517-15.623	Kettingspanner R.	1	1	1
12	517-15.112	Tandwielrubber	6	6	6
13	517-15.915	Naafflens afb. 13-15	1	1	1
14	561-17.111	Moer	6	6	6
15	DIN 931 M 8x25/14	Bout	6	6	6
--	DIN 127 B 8	Veerring	6	6	6
16	DIN 625 6203 Z	Kogellager 17x40x12	1	1	1
17	433-15.117	Afdekplaat	1	1	1
18	433-15.119	Viltring	1	1	1
19	433-15.121	Kap	1	1	1
20	423-15.405	Kettingwiel 41 tanden	1	-	-

Alu-achterwiel - naaf ϕ 150 mm

voor GTS, KS,
voor CS vanaf framennr. 9 149 450

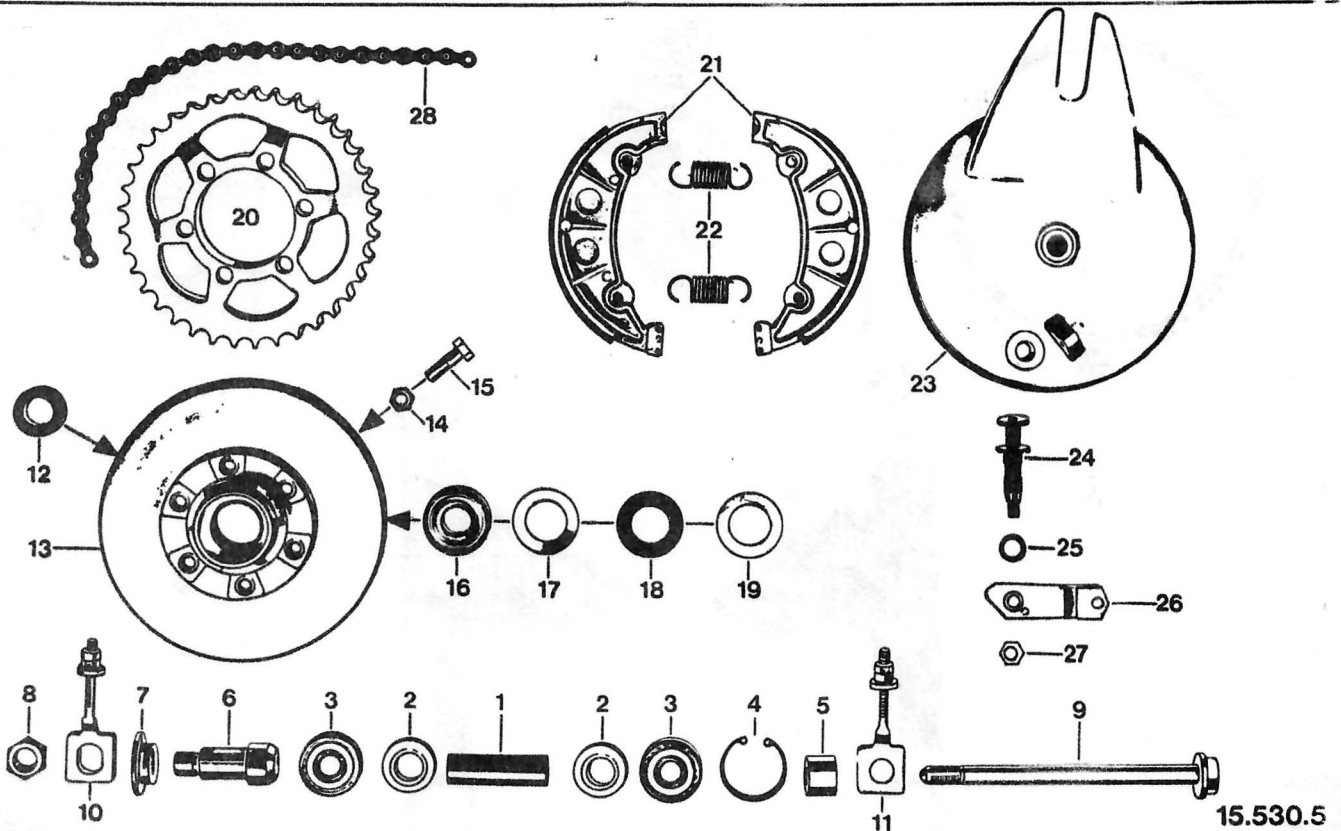

Afb.	Bestelnummer	Omschrijving	CS	GTS	KS
20	423-15.406	Kettingwiel 43 tanden	-	1	1
21	517-15.921	Remsegmenten (set)	1	1	1
22	517-15.133	Remsegmentveer	2	2	2
23	517-15.611	Remankerplaat	1	1	1
24	517-15.606	Remsleutel	1	1	1
25	405-15.388	O-Ring	1	1	1
--	267-05.597	Vulschijf 0,2 mm	1	1	1
26	530-15.611	Remhevel	1	1	1
27	DIN 936 M 8x1	Moer	1	1	1
28	429-18.640	Ketting met slot 1/2"x3/16" 114 schakels	1	-	-
28	517-18.609	Ketting met slot 1/2"x3/16" 122 schakels	-	1	1
--	432-18.900	Slot voor ketting 1/2"x3/16"	1	1	1
--	530-15.111	Buitenband 2 3/4 - 17	1	1	1
--	433-15.216	Binnenband 2 3/4 - 17	1	1	1

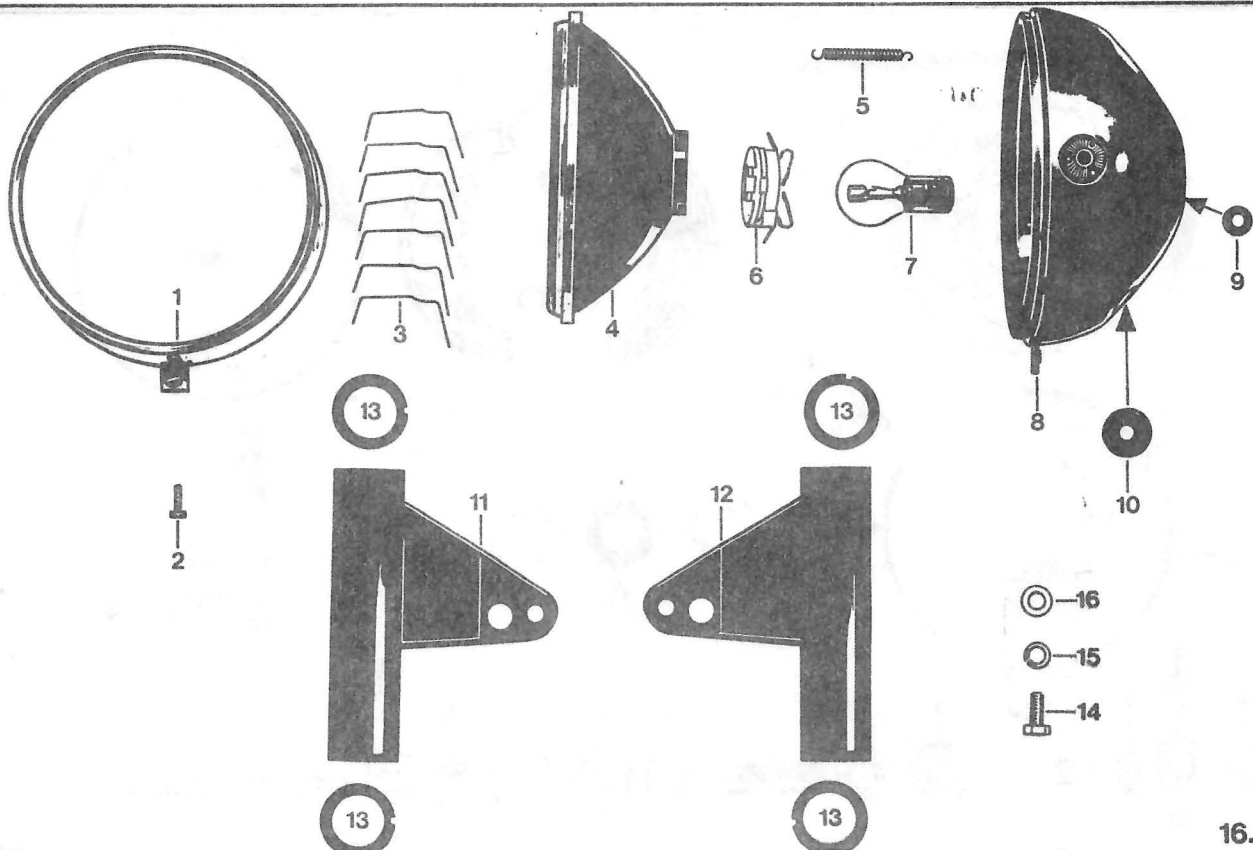

16.530.1

Afb.	Bestelnummer	Omschrijving	CS	GTS	KS
-	517-16.797	Inbouwset kpl. 6V, C 15/15W zonder lampje	1	-	-
-	529-16.709	Inbouwset kpl. 6V, 15/15W met lampje	-	1	1
-	517-16.949	Lamprand met bout	1	-	-
1	519-16.919	Lamprand met bout	-	1	1
2	517-16.950	Sluitbout	1	1	1
-	517-16.951	Glasrandveren	6	-	-
3	517-16.933	Glasrandveren	-	6	6
-	518-16.619	Lampglas met reflektor	1	-	-
4	519-16.921	Lampglas met reflektor	-	1	1
-	517-16.931	Veer	1	-	-
5	519-16.923	Veer	-	1	1
-	517-16.944	Fitting met draad aansluiting	1	-	-
6	519-16.920	Fitting met stekker aansluiting	-	1	1
-	DIN 72601 6V, C15/15W	Lampje	1	-	-
7	442-16.119	Lampje 6 V, 15/15 W	-	1	1
-	529-16.608 <u>kleur</u>	Koplamphuis	1	-	-
8	529-16.609 <u>kleur</u>	Koplamphuis	-	1	1
9	M 1806 z 59	Kabeltule	-	2	2
10	517-16.239	Kabeltule	2	2	2
11	529-16.601 <u>kleur</u>	Houder L.	1	1	1
12	529-16.602 <u>kleur</u>	Houder R.	1	1	1
13	517-12.182	Bus	4	4	4
14	DIN 933 M 8x20	Bout	2	2	2
15	DIN 127 B 8	Veerring	2	2	2
16	DIN 125 A 8,4	Ring	2	2	2

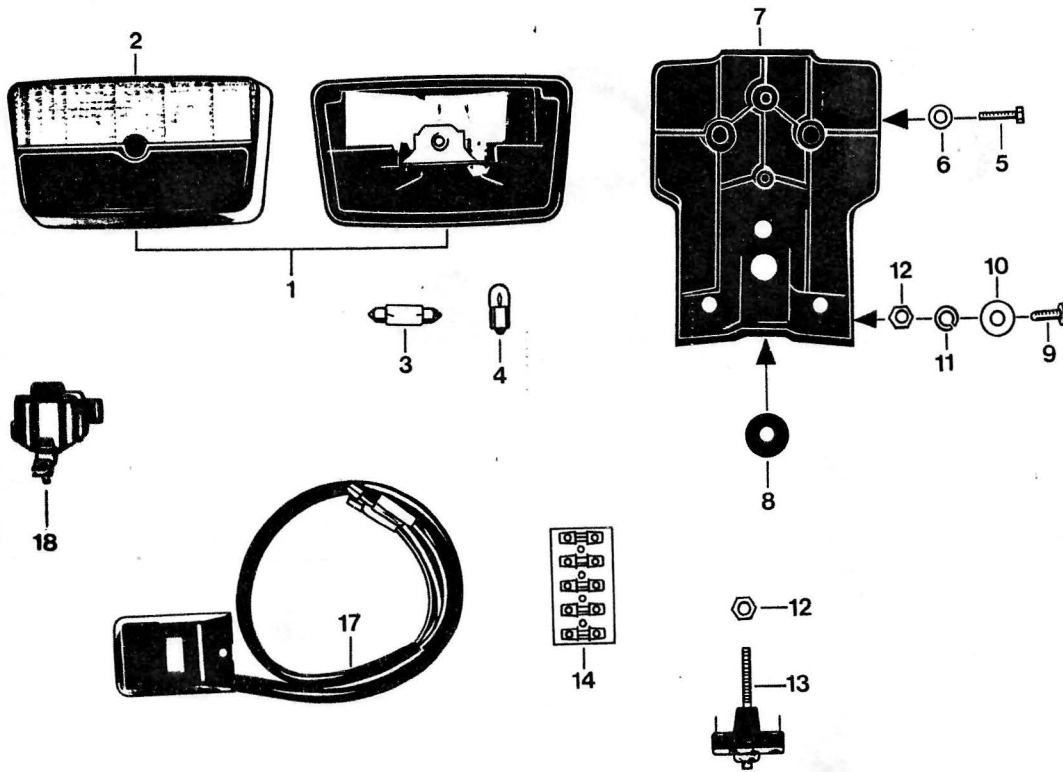

16.529.3

Afb.	Bestelnummer	Omschrijving	CS	GTS	KS
1	529-16.711	Achterlicht -zonder lampje-	1	-	-
1	529-16.741	Achterlicht -zonder lampje-	-	1	1
2	529-16.903	Achterlichtglas	1	1	1
3	DIN 72601 L6V, 5W	Lampje voor stoplicht	1	1	1
4	DIN 72601 HL6V, 4W	Lampje voor achterlicht	1	-	-
4	517-16.379	Lampje H6V, 3W voor achterlicht-	1	1	1
5	DIN 84 AM 5x16	Bout	1	1	1
6	DIN 137 A 5	Veerring	1	1	1
7	529-16.611	Achterlichtsteun	1	1	1
8	520-12.282	Kabeltule	1	1	1
9	DIN 933 M 6x16	Bout	3	3	3
10	DIN 9021 A 6,4	Ring	6	6	6
11	DIN 127 B 6	Veerring	3	3	3
12	DIN 934 M 6	Moer	5	5	5
13	517-16.113	Stoplichtschakelaar	1	1	1
14	446-16.125	Kabelverbinder 6-delig	3	4	4
17	519-16.792	Dimschakelaar cpl.	-	1	1
18	518-16.742	Dimschakelaar kaal	1	-	-
--	529-16.635	Kabelboom	1	-	-
--	529-16.622	Kabelboom	-	1	1

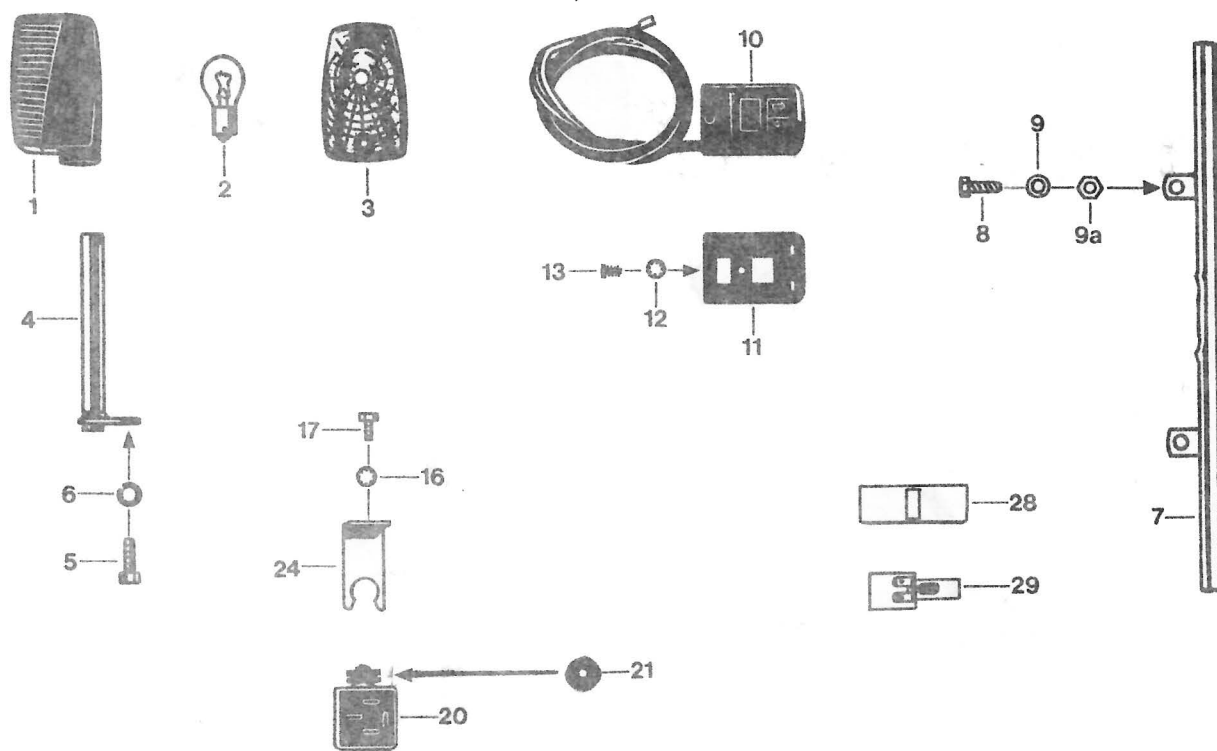

16.529.7

Afb.	Bestelnummer	Omschrijving	GTS	KS
1	519-16.770	Knipperlicht -zonder lampje-	-	4
2	DIN 72601 G6V, 5W	Lampje	-	4
3	519-16.181	Knipperlichtglas oranje	-	4
4	519-16.618	Houder knipperlicht voor	-	2
5	DIN 933 M 8x20	Bout	-	2
6	DIN 127 B 8	Veerring	-	2
7	529-16.625	Houder knipperlicht achter	-	1
8	DIN 933 M 6x12	Bout	-	2
9	DIN 127 B 6	Veerring	-	2
9a	DIN 934 M 6	Moer	-	2
10	519-16.760	R. A. W. schakelaar compl.	1	1
11	529-16.113	Schalteraufnahme	1	-
12	DIN 6797 J 5,3	Vulschijf	1	-
13	DIN 7971 B4,8x9,5	Bout	1	-
--	DIN 7971 B 3,9x16	Bout	1	-
16	DIN 6797 A 6,4	Vulschijf	1	1
17	DIN 933 M 6x12	Bout	1	1
20	529-16.642	Automaat	1	1
21	529-16.126	Rubber tule	1	1
24	529-16.109	Plaat	1	1
28	520-16.376	Stekker	2	2
29	686-16.129	Stekker	1	1

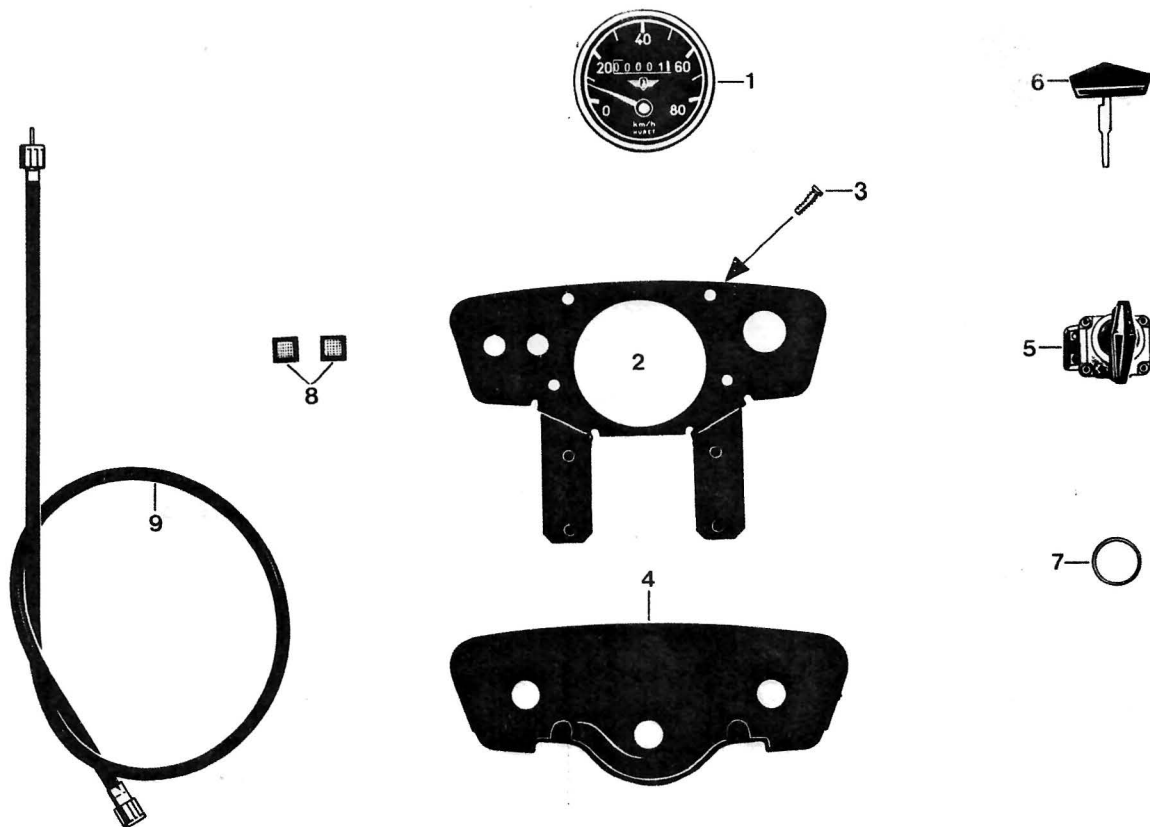

16.529.4

Afb.	Bestelnummer	Omschrijving	CS	GTS
1	529-16.907	Tellerklok \varnothing 60, 80 km/h	1	1
-	DIN 72601 J6V, 0,6W	Lampje voor tellerklok	1	1
-	529-16.124	Beugel voor tellerklok	1	1
-	529-16.125	Moer voor tellerklok	1	1
2	529-16.600	Drager	1	1
3	DIN 7981 BZ4,8x13	Bout	4	4
4	517-16.372	Tellerhuis	1	1
5	519-16.780	Kontaktschakelaar compl.	1	1
6	515-16.939	Kontaktsleutel	1	1
7	517-16.376	Tussenring	1	1
8	519-16.612	Controle glas groen	1	1
8	517-16.667	Signal glas rood	1	1
9	519-16.668	Tellerkabel	1	1

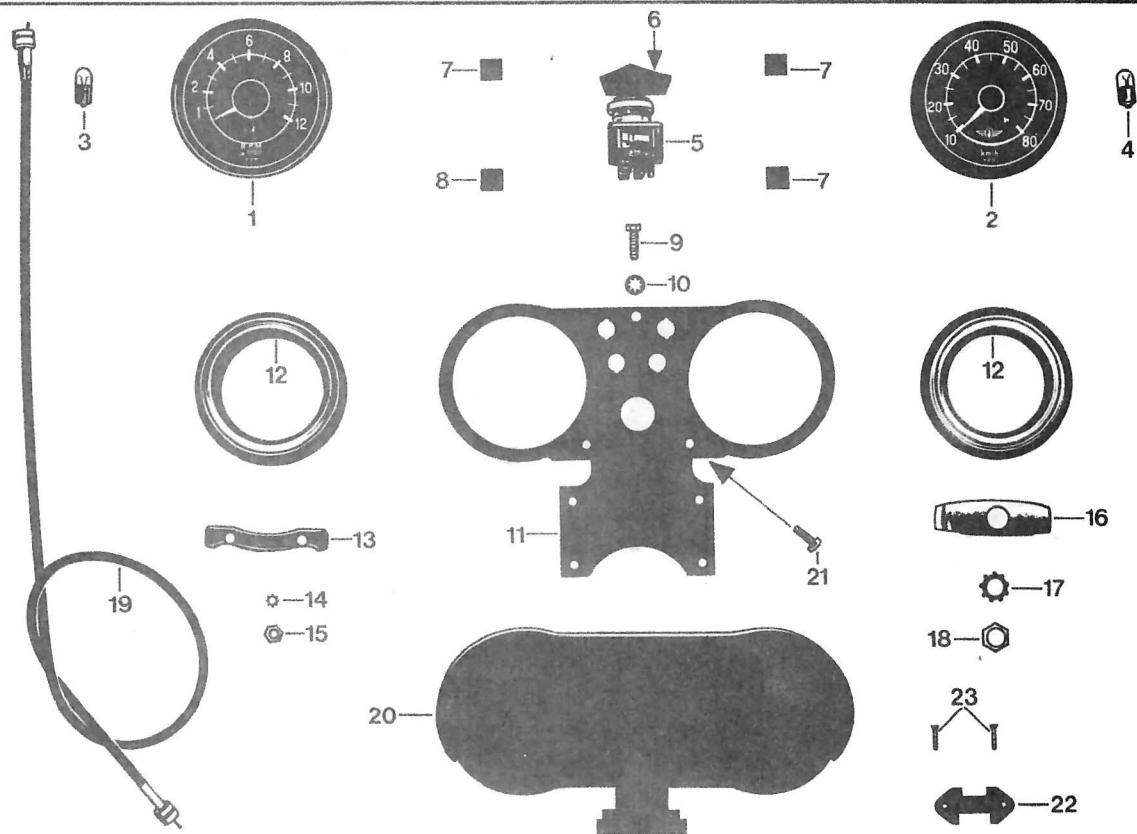

16.529.5

Afb.	Bestelnummer	Omschrijving	KS
1	529-16.909	Toerenteller	1
2	529-16.908	Tellerklok 80 km/h	1
3	DIN 72601 J6V, 0,6W	Lampje	1
4	DIN 72601 J6V, 0,6W	Lampje	1
5	519-16.780	Kontaktschakelaar compl.	1
6	515-16.939	Kontaktsleutel	1
7	519-16.612	Controle glas groen	3
8	517-16.667	Signal glas rood	1
9	DIN 933 M 5x15	Bout	1
10	DIN 6797 J 5,3	Vulschijf	1
11	529-16.605	Drager	1
12	521-16.602	Houder compl.	2
13	530-16.106	Beugel voor toerenteller	1
14	DIN 6797 A 4,3	Vulschijf	2
15	DIN 934 M 4	Moer	2
16	530-16.105	Beugel voor tellerklok	1
17	DIN 6797 A 10,5	Vulschijf	1
18	529-16.115	Moer	1
19	517-16.652	Tellerkabel	1
20	517-16.322	Cockpithuis	1
21	DIN 7981 BZ4,8x13	Bout	3
22	517-16.384	Plaatje	1
23	DIN 7972 BZ2,9x9,5	Bout	2

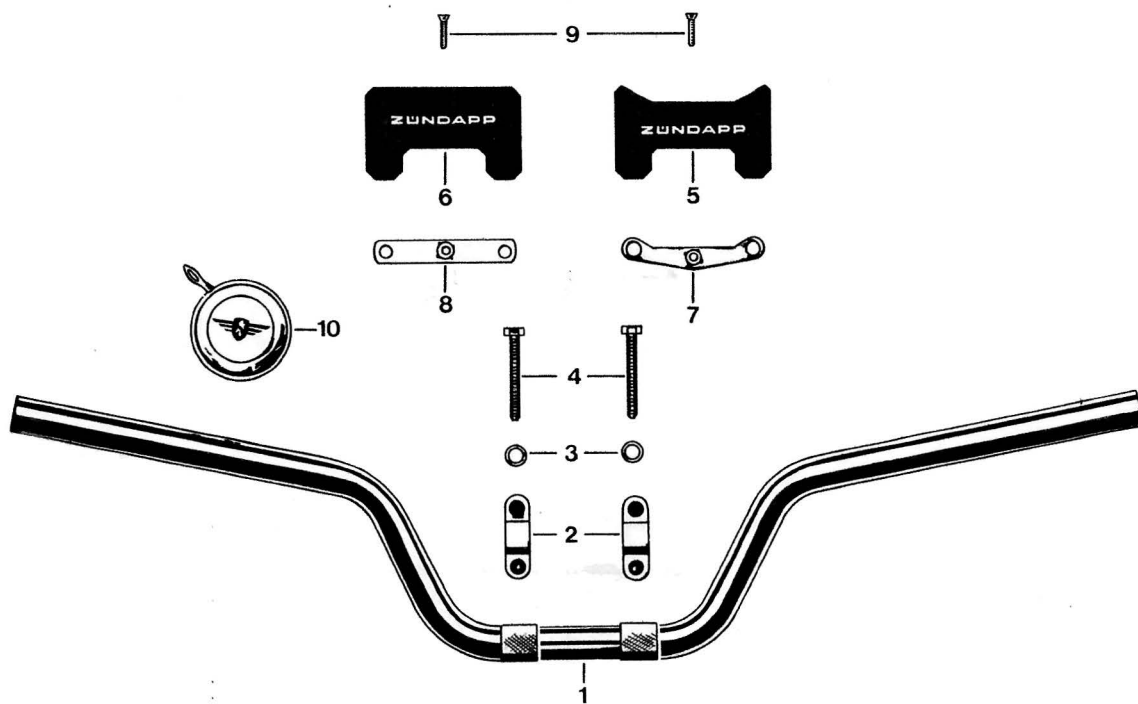

13.529.1

Afb.	Bestelnummer	Omschrijving	CS	GTS	KS
1	529-13.603	Stuur	1	1	1
-	529-10.160	Slothouder	1	1	1
2	529-13.100	Stuurklem	2	2	2
3	DIN 125 A 7,4	Ring	2	2	2
4	DIN 933 M 7x50	Bout	4	4	4
5	529-13.102	Afdekplaatje	1	1	-
6	517-13.131	Afdekplaatje	-	-	1
7	529-13.600	Houder	1	1	-
8	517-13.615	Houder	-	-	1
9	DIN 964 AM 5x20	Bout	1	1	1
10	400-17.610	Bel	1	1	1

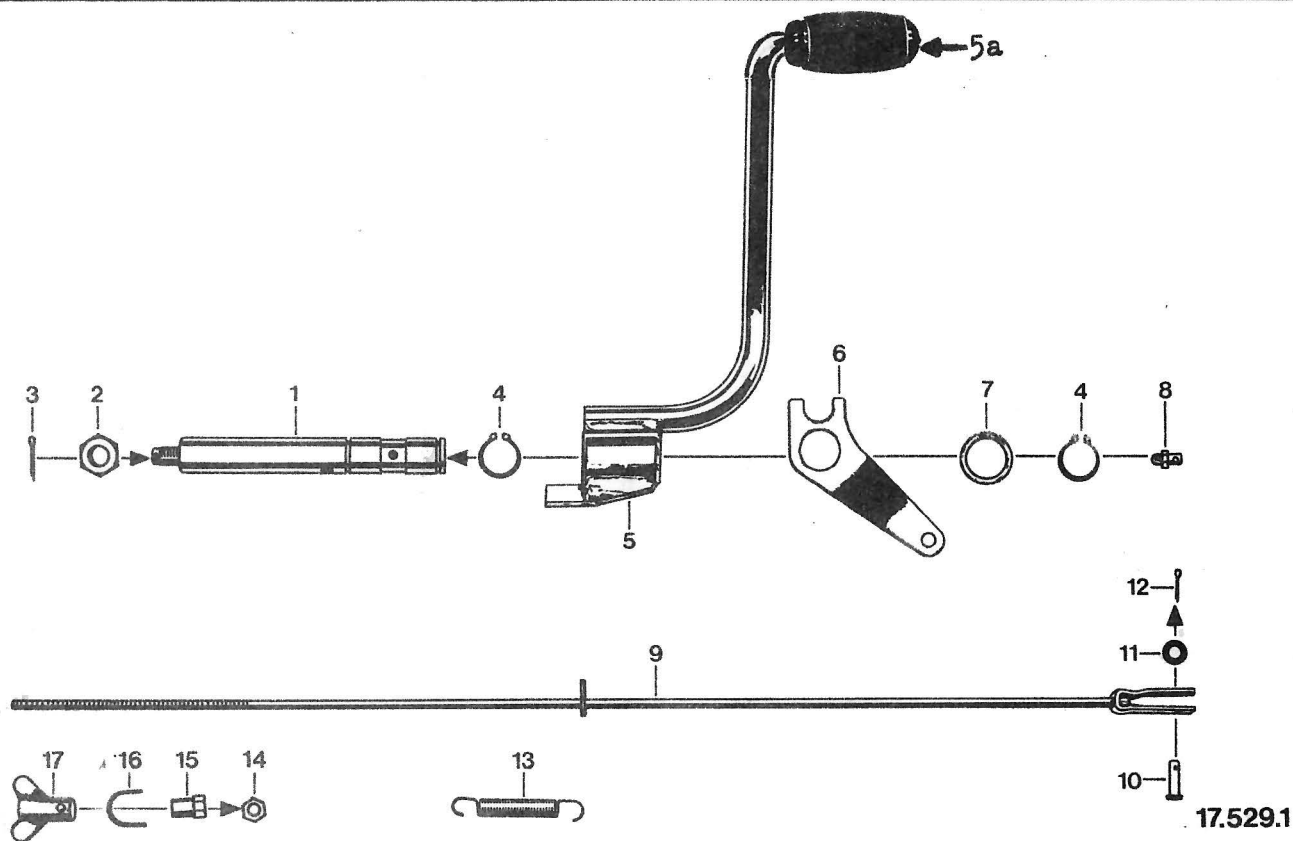

Afb.	Bestelnummer	Omschrijving	CS	GTS	KS
1	517-18.103	Pedaalas	1	1	1
2	DIN 936 M 10x1	Moer	1	1	1
3	DIN 94 2x18	Splitpen	1	1	1
4	DIN 471 18x1,2	Borgveer	2	2	2
-	529-17.605	Voetrempedaal met rubber	1	-	-
5	529-17.631	Voetrempedaal met rubber	-	1	1
5a	616 z 25	Rubber	1	1	1
6	529-17.102	Meeneemplaas	1	1	1
7	517-17.110	Vulschijf	1	1	1
8	DIN 71412 AM 6	Smeernippel	1	1	1
9	529-17.600	Remstang	1	1	1
10	519-17.106	Scharnierpen	1	1	1
11	DIN 125 A 6,4	Ring	1	1	1
12	DIN 94 2x12	Splitpen	1	1	1
13	529-17.105	Remstang trekveer	1	1	1
14	DIN 934 M 6	Moer	1	1	1
15	512-17.100	Moer	1	1	1
16	433-17.100	Remstangbeugel	1	1	1
17	428-17.103	Vleugelmoer	1	1	1

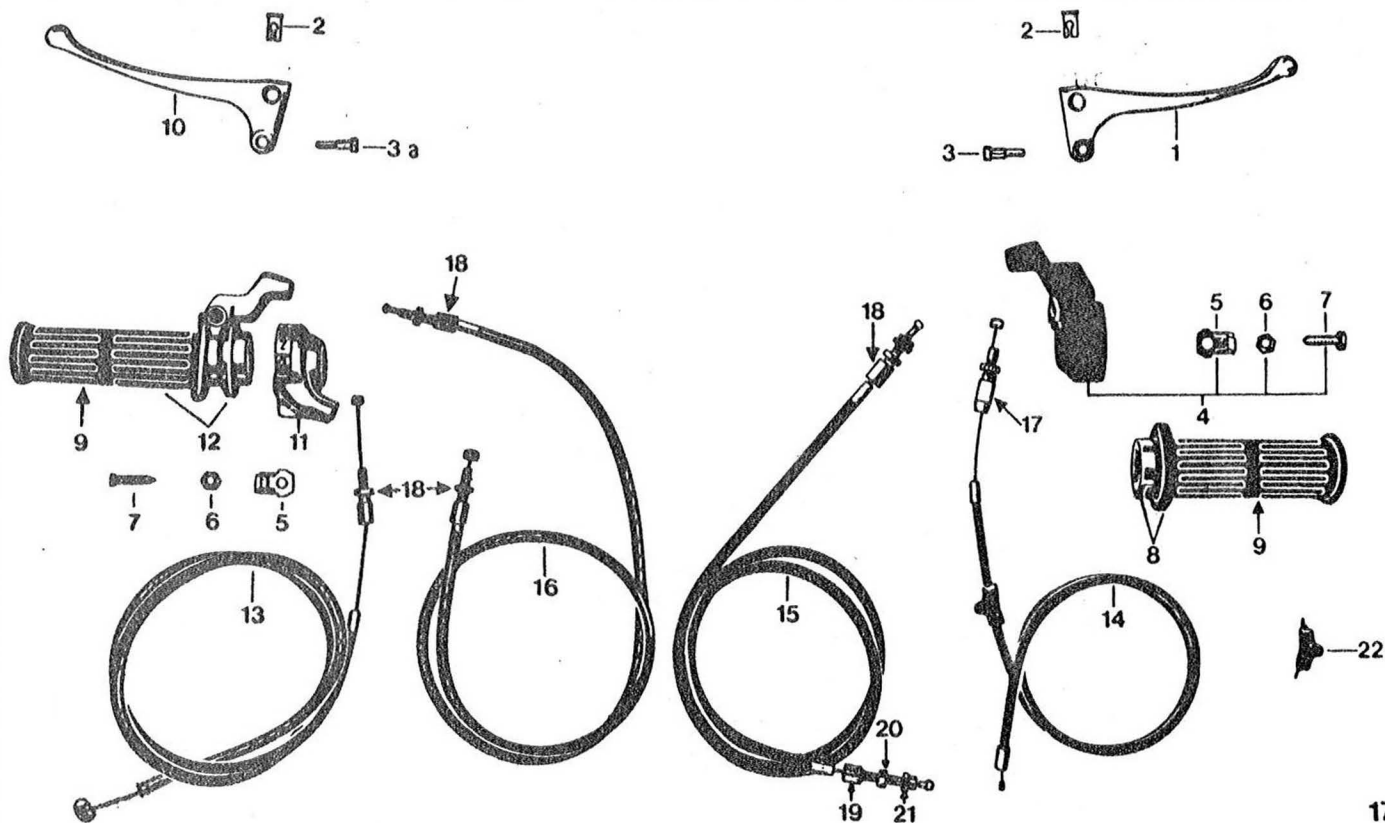

17.529.2

Afb.	Bestelnummer	Omschrijving	CS
-	529-17.704	Gashandle compleet	1
1	442-17.907	Remhandgreep	1
2	428-17.115	Nippelhouder	2
3	408-17.903	Handgreepbout	1
3a	510-17.911	Handgreepbout	1
4	517-17.904	Gashandlehuis	1
5	515-17.904	Haaksebevestigingsbeugel	2
6	515-17.907	Moer	2
7	515-17.913	Drukstift	2
8	529-17.900	Gashandle-draaigedeelte	1
9	446-17.905	Handvatrubber	2
-	529-17.707	Schakelhandle compleet	1
10	434-17.902	Koppelingshandgreep	1
11	433-17.901	Schakelhandlehuis	1
12	446-17.906	Schakelhandle draaigedeelte	1
13	529-17.627	Schakelkabel A 1,6x1060	1
14	529-17.628	Gaskabel A 1x938	1
15	529-17.609	Remkabel A 1,8x1081	1
16	529-17.608	Koppelingskabel A 1,6x972	1
17	515-17.719	Stelbout	1
18	428-17.715	Stelbout	4
19	400-17.141	Stelschroef	1
20	400-17.142	Moer	1
21	400-17.140	Stelring	1
22	521-17.607	Plastic smeernippel	1

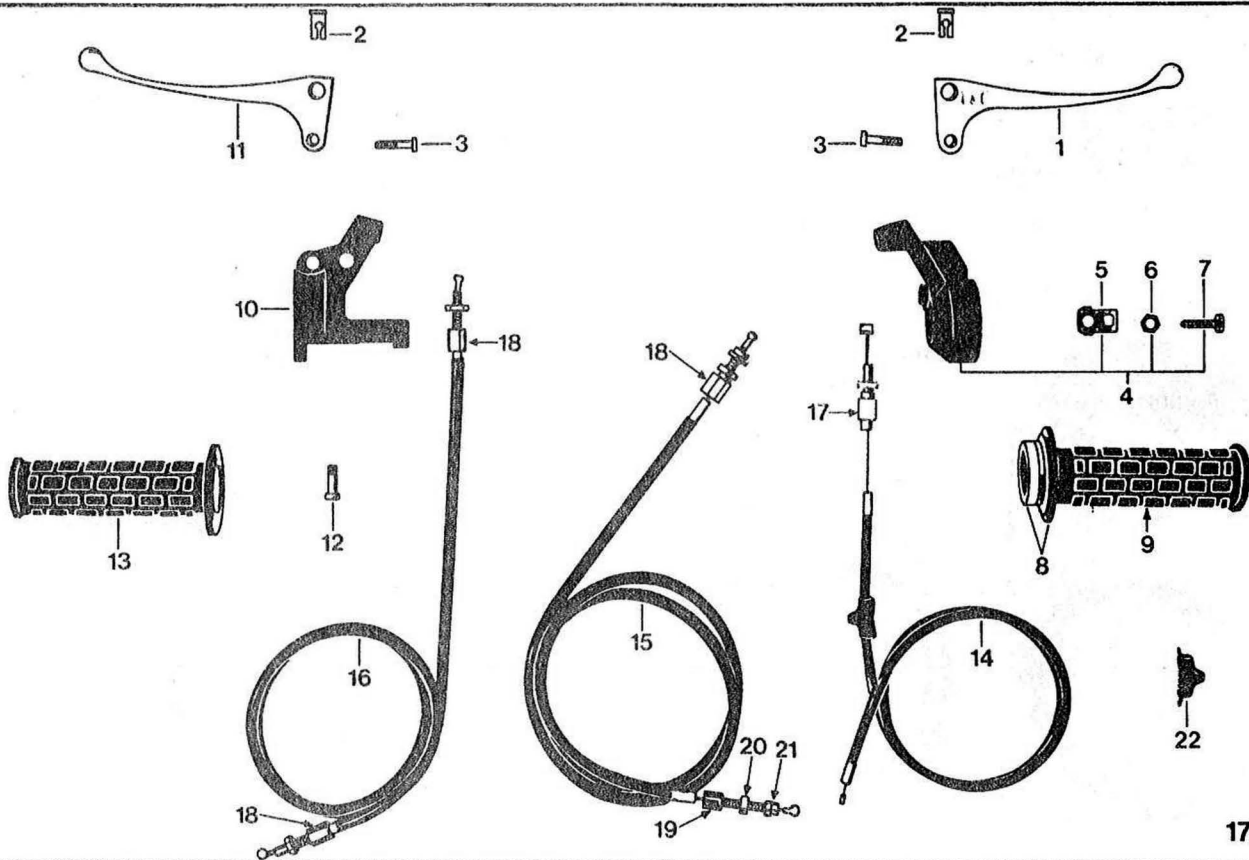

17.529.3

Afb.	Bestelnummer	Omschrijving	GTS
-	529-17.706	Gashandle compl.	1
1	517-17.909	Remhandgreep	1
2	428-17.115	Nippelhouder	2
3	408-17.903	Handgreepbout	2
4	517-17.729	Gashandlehuis	1
5	515-17.904	Haaksbevestigingsbeugel	1
6	515-17.907	Moer	1
7	515-17.913	Drukstift	1
8	529-17.901	Gashandle-draaigedeelte	1
9	529-17.902	Handvatrubber R.	1
-	517-17.739	Koppelingshandle' compl.	1
10	517-17.922	Scharnierstuk	1
11	517-17.912	Koppelingshandgreep	1
12	400-17.912	Bout	1
13	529-17.113	Handvatrubber L.	1
14	529-17.607	Gaskabel A 1x945	1
15	529-17.609	Remkabel A 1,8x1081	1
16	529-17.608	Koppelingskabel A 1,6x972	1
17	515-17.719	Stelbout	1
18	428-17.715	Stelbout	3
19	400-17.141	Stelschroef	1
20	400-17.142	Moer	1
21	400-17.140	Stelring	1
22	521-17.607	Plastic smeernippel	1

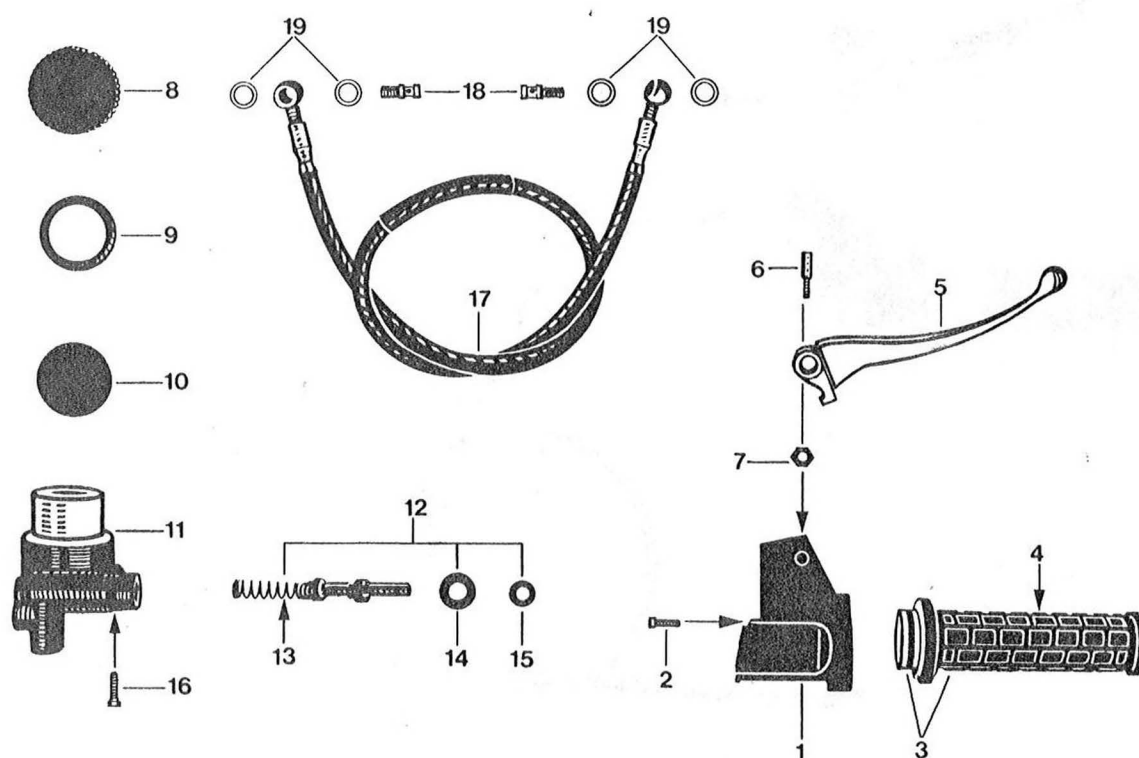

17.530.3

Afb.	Bestelnummer	Omschrijving	KS
-	530-17.721	Gashandle met remcilinder	1
1	530-17.703	Gashandlehuis kpl.	1
2	400-17.912	Bout	1
3	530-17.916	Gashandle-draaigedeelte	1
4	530-17.915	Handvatrubber R.	1
5	530-17.914	Remhandgreep	1
6	530-17.901	Bout voor handgreep	1
7	530-17.910	Zekeringsmoer M 6	1
8	530-17.902	Vuldop	1
9	530-17.903	Vulschijf	1
10	530-17.904	Balg voor cilinder	1
11	530-17.706	Cilinder compleet	1
12	530-17.707	Zuiger compleet	1
--	530-17.705	Cilinder compl. + zuiger compl. afb. 8 - 12	1
13	530-17.908	Drukveer voor zuiger	1
14	530-17.906	Vulschijf 10x22	1
15	530-17.905	Afsluiter voor zuiger	1
16	DIN 912 M 5x16	Bout	2
17	530-17.702	Remsleiding compl. afb. 17-19	1
18	530-17.911	Banjo-bout M 10x1	2
19	530-17.912	Afdichtring 10x14	4

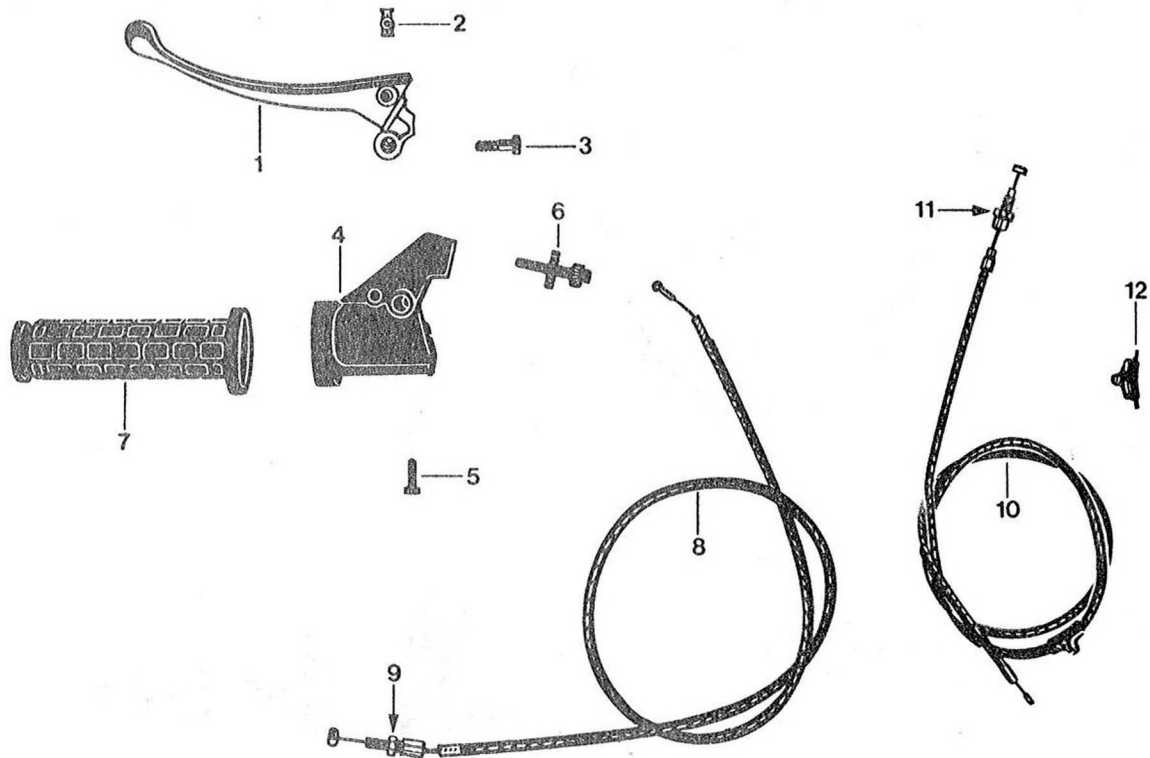

17.530.2

Afb.	Bestelnummer	Omschrijving	KS
-	530-17.720	Koppelingshandle compl.	1
1	530-17.913	Koppelingshandgreep	1
2	428-17.115	Nippelhouder	1
3	425-17.902	Handgreepbout	1
4	517-17.733	Scharnierstuk	1
5	400-17.912	Bout	1
6	425-17.718	Stelbout	1
7	530-17.107	Handvatrubber L.	1
8	530-17.603	Koppelingskabel A 1,6x950	1
9	428-17.715	Stelbout	1
10	529-17.623	Gaskabel A 1x982	1
11	517-17.180	Stelbout	1
12	521-17.607	Plastic smeernippel	1

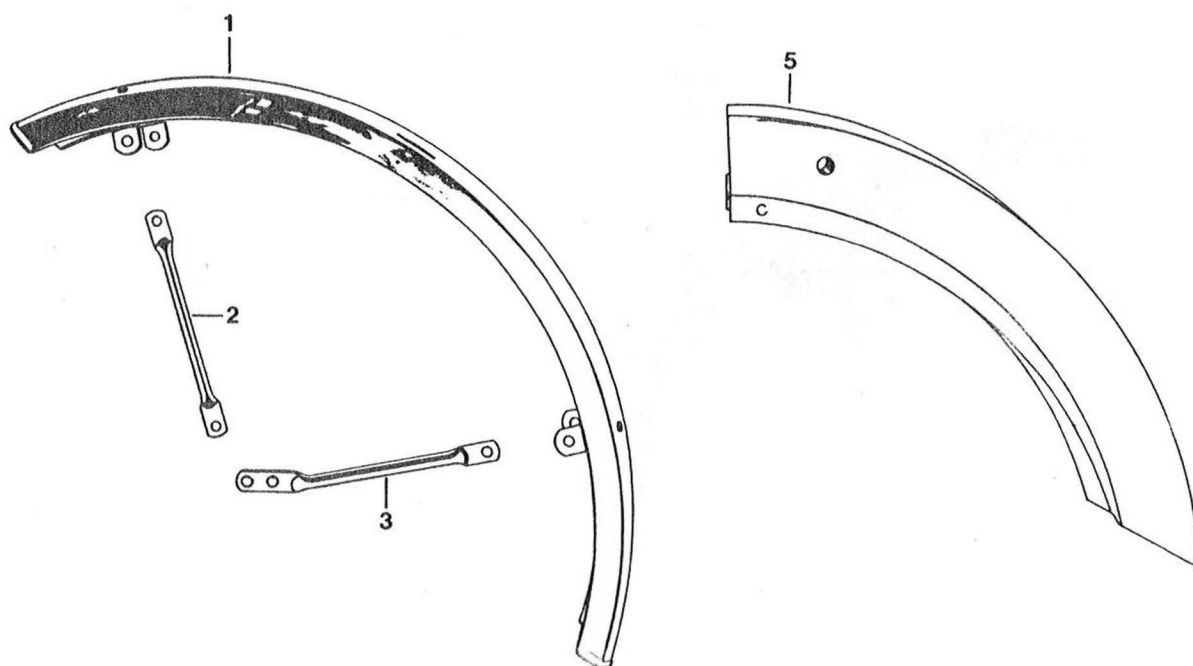

19.529.1

Afd.	Bestelnummer	Omschrijving	CS	GTS
1	529-16.607 kleur	Voorspatscherm	1	-
-	530-19.900	Voorspatscherm -verchroomd-	-	1
2	529-19.104	Bovenbeugel	2	2
3	529-19.103	Onderbeugel	2	2
-	DIN 7985 AM 6x10	Bout	10	10
-	DIN 6797 A 6,4	Vulschijf	6	6
-	DIN 934 M 6	Moer	6	6
-	517-22.111	Zekeringsmoer M 6	4	4
-	1236 z 06	Rubber	1	1
5	529-19.613	Achterspatscherm	1	-
-	529-19.612	Achterspatscherm -verchroomd-	-	1
-	529-19.106	Wit oplegstrip voor A	1	1
-	DIN 84 AM 6x16	Bout	4	4
-	DIN 933 M 6x18	Bout	2	2
-	1301 z 1019	Vulschijf 6,2x22x1	2	2
-	DIN 125 A 6,4	Vulschijf	2	2
-	DIN 137 B 6	Veerring	6	6
-	DIN 934 M 6	Moer	6	6

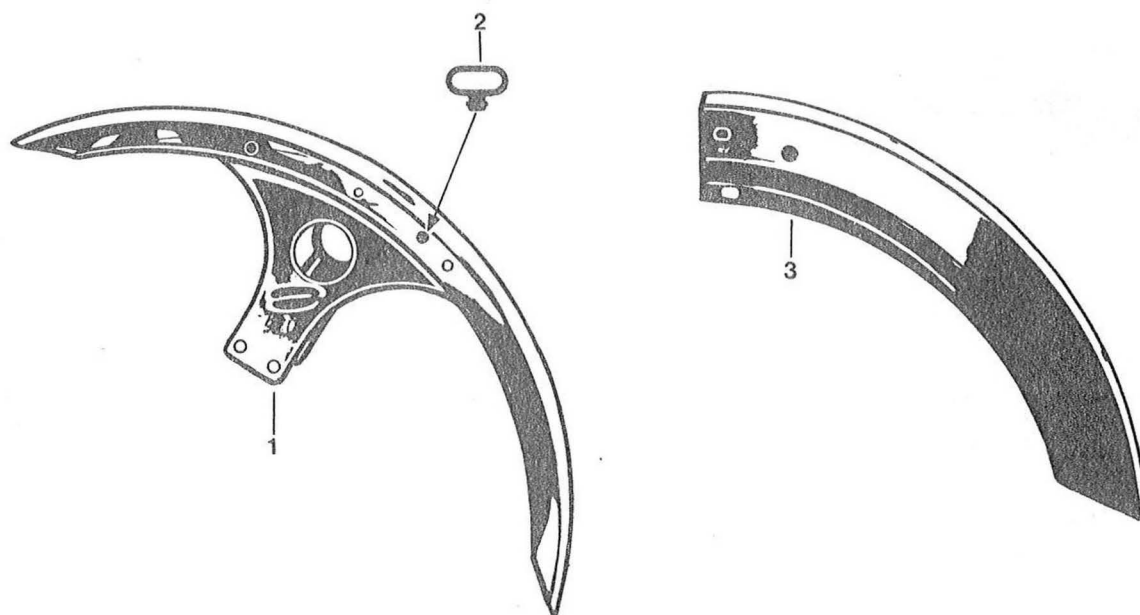

19. 530. 1

Afb.	Bestelnummer	Omschrijving	KS
1	530-19.605	Voorspatbord -verchroomd-	1
2	530-19.101	Houder voor remsleiding	2
-	DIN 933 M 6x12	Bout	4
-	DIN 6797 A 6,4	Vulschijf	4
-	DIN 125 A 6,4	Vulschijf	4
3	529-19.612	Achterspatbord -verchroomd-	1
-	529-19.106	Wit oplegstrip voor A	1
-	DIN 84 AM 6x16	Bout	4
-	DIN 933 M 6x18	Bout	2
-	DIN 125 A 6,4	Vulschijf	2
-	1301 z 1019	Vulschijf 6,2x22x1	2
-	DIN 137 B 6	Veerring	6
-	DIN 934 M 6	Moer	6

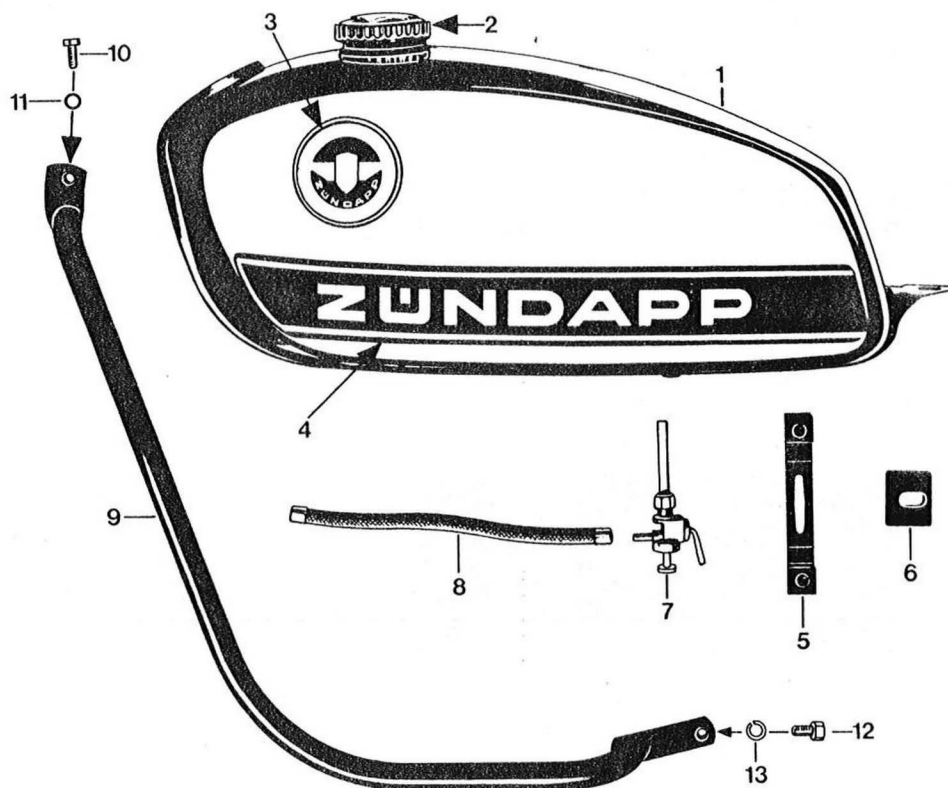

20.529.1

Afb.	Bestelnummer	Omschrijving	CS	GTS	KS
1	529-20.700 kleur	Benzinetank	1	1	1
2	432-20.610	Tankdop	1	1	1
3	517-20.142	Tankembleem	2	2	2
4	529-20.106	Transfer "ZÜNDAPP" L.	1	1	1
-	529-20.107	Transfer "ZÜNDAPP" R.	1	1	1
-	529-20.114	Tanktransfer	1	1	1
-	517-20.153	Transfer "Trophy"	1	1	1
5	529-20.109	Rubber buffer	1	1	1
6	529-20.105	Rubber buffer	1	1	1
7	428-20.712	Benzinekraan	1	1	1
8	DIN 73379 A 5x9x620	Benzineslang	1	1	1
9	529-10.605	Beugel L.	-	1	1
-	529-10.606	Beugel R.	-	1	1
10	DIN 933 M 8x16	Bout	-	2	2
11	DIN 127 B 8	Veerring	-	2	2
12	DIN 912 M 8x16	Bout	-	2	2
13	DIN 7980 B 8	Veerring	-	2	2
--	517-20.752	Gereedschap-set	1	1	1
--	517-20.603	Bougie sleutel SW 17/21	1	1	1
--	444-20.600	Luchtpomp	1	1	1

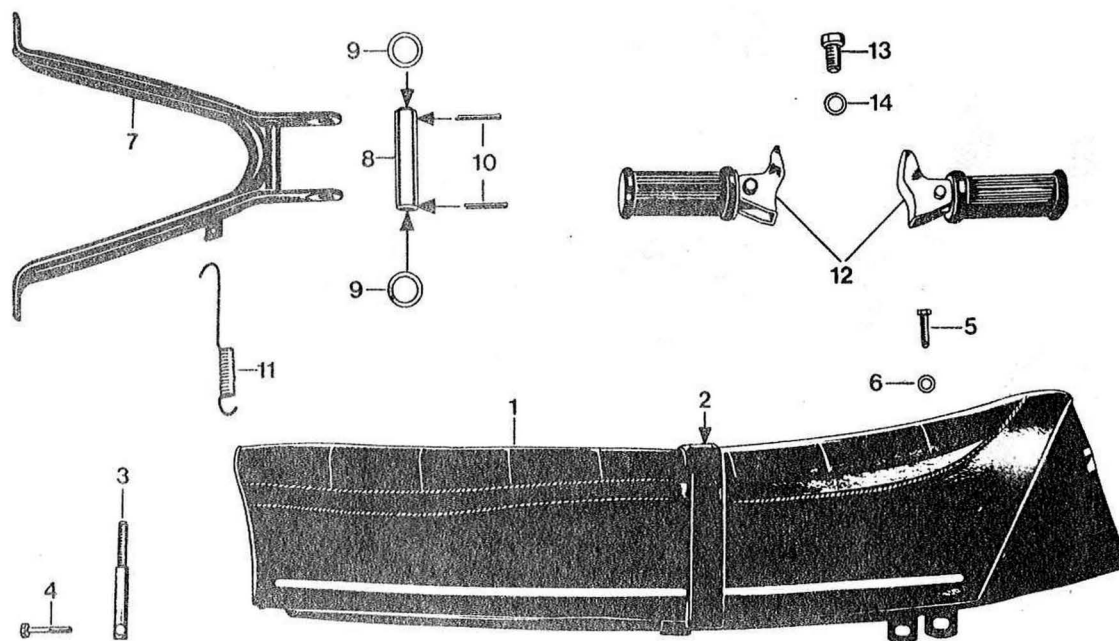

21.529.1

Afb.	Bestelnummer	Omschrijving	CS
1	529-21.603	Buddyseat	1
2	529-21.900	Buddyseatriem	1
3	517-21.104	Buddyseatbout	1
-	400-20.106	Vulschijf	1
4	DIN 931 M 6x35	Bout	1
5	DIN 933 M 7x25	Bout	2
6	DIN 127 B 7	Veerring	2
7	517-21.608	Middenstandaard	1
8	517-21.116	Standaardbus	1
9	517-21.113	Vulschijf	2
10	DIN 94 3,2x28	Splitpen	2
11	517-21.109	Standaardveer	2
12	425-14.670	Duo-voetsteunen (stel)	1
13	DIN 933 M 10x18	Bout	2
14	DIN 127 B 10	Veerring	2

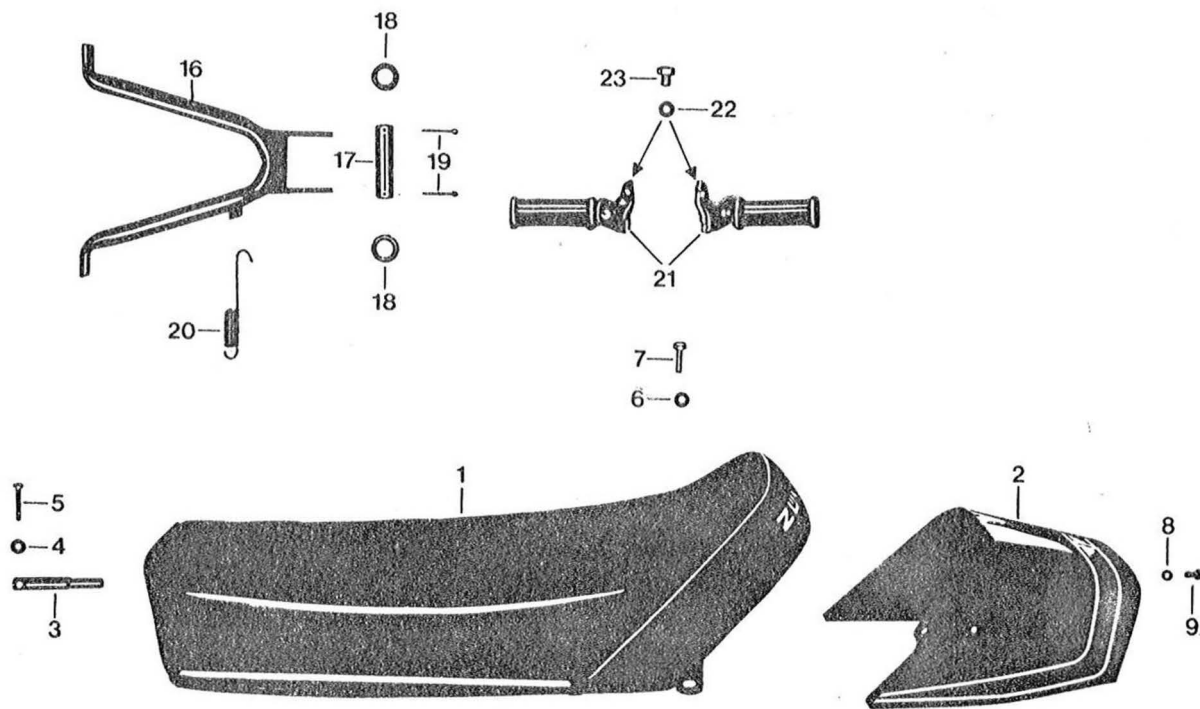

21.530.1

Afb.	Bestelnummer	Omschrijving	GTS	KS
1	530-21.603	Buddyseat	1	1
2	529-21.604	Spoiler	1	1
-	530-21.102	Transfer voor spoiler	1	1
3	517-21.104	Buddyseatbout	1	1
4	400-20.106	Vulschijf	1	1
5	DIN 931 M 6x35	Bout	1	1
6	DIN 127 B 7	Veerring	2	2
7	DIN 933 M 7x25	Bout	2	2
8	DIN 137 B 6	Veerring	3	3
9	DIN 933 M 6x18	Bout	3	3
-	529-16.122	Reflector (voor spoiler)	1	1
-	DIN 84 AM 5x14	Bout	2	2
-	DIN 137 A 5	Veerring	2	2
16	517-21.608	Middenstandaard	1	1
17	517-21.116	Standaardbus	1	1
18	517-21.113	Vulschijf	2	2
19	DIN 94 3,2x28	Splitpen	2	2
20	517-21.109	Standaardveer	2	2
21	425-14.670	Duo-voetsteunen (stel)	1	1
22	DIN 127 B 10	Veerring	2	2
23	DIN 933 M 10x18	Bout	2	2



ZÜNDAPP-WERKE GMBH MÜNCHEN