

# ZÜNDAPP

ONDERDELEN-CATALOGUS 6-1980  
TYPEN 529

CS50-GTS50-KS50

Catalogus voor de typen

Type	vanaf Framenr.	Motortype	vanaf Motornr.	Kleur
CS 50 = 529-030	9110031 - 9195839	266-720	9595301 - 9773422	33, 67
CS 50 = 529-032	9195839 - 9280648	266-720	9595301 - 9773422	33, 67
CS 50 = 529-034	9280649 -	266-721	9773423 -	33, 67
GTS 50 = 529-050	9102751 - 9195839	280-770	9586404 - 9779088	67
GTS 50 = 529-052	9195840 - 9284713	280-770	9586404 - 9779088	67, 70
GTS 50 = 529-054	9284714 - 9332082	280-772	9779089 - 9829442	67, 70
GTS 50 = 529-056	9332083 -	280-774	9829443 -	67, 70
KS 50 = 529-051	9102731 - 9195839	280-771	9586334 - 9773772	67
KS 50 = 529-053	9195840 - 9280823	280-771	9586334 - 9773772	67, 70
KS 50 = 529-055	9280824 - 9315844	280-773	9773773 - 9810635	67, 70
KS 50 = 529-057	9315845 -	280-775	9810636 -	67, 70

Kleur-aanduiding

33 = briljant-blauw

67 = goud-oranje lasuur

70 = zilver

Uitgegeven door ZÜNDAPP WERKE GMBH MÜNCHEN in samenwerking met de  
2 ZÜNDAPP importeurs voor nederland Groninger Motorimport B.V., Handels-  
sonderneming Riemersma B.V. afd. Ramo.

I N H O U D S O P G A V E

Motorisch-gedeelte	Bldz.		
	CS	GTS	KS
Carterdeksel links - kickstarter - voetschakelas .....	-	4	4
Koelingskap - schoepenrad .....	6	-	-
Carterhelft links - carterdeksel links - lagers .....	7	-	-
Carterhelft links .....	-	8	8
Carterhelft rechts .....	9	10	10
Carterdeksel rechts - koppelingshevel .....	11	11	11
Koppeling .....	12	12	12
Cylinder - krukas .....	13	13	13
Carburateur .....	14	--	--
Carburateur .....	tot motornr. 9 810 635	15	15
Carburateur .....	vanaf motornr. 9 810 636	16	16
Aanzuigflens en rubber - geruisdemper .....	18	18	18
Schakelhevel - schakelvork - trapas .....	19	--	--
Versnellingsbak - onderdelen - kettingwiel .....	20	21	21
Ontsteking 6 V, 24 W .....	22	--	--
Ontsteking 6 V, 33 W .....	--	23	23
Uitlaatbocht - demper en bevestigingen .....	24	24	24

Frame-gedeelte

Frame - framebeplating - stuurslot - balhoofdstel .....	25	25	25
Trapas - kranks - pedalen .....	26	26	26
Motorophanging .....	27	27	27
Telescoopvoorvork .....	28	28	29
Achtersvork - kettingkast - schokbrekers .....	30	30	30
Alu-voorwiel - naaf $\emptyset$ 150 mm - remtrommel .....	31	31	--
Alu-voorwiel - remschijf $\emptyset$ 220 mm .....	--	--	32
Remklauw .....	--	--	33
Alu-achterwiel - naaf $\emptyset$ 150 mm .....	34	34	34
Koplamp - koplamphouders .....	36	36	36
Achterlicht - dimeschakelaar - kabelboom .....	37	37	37
R. A. W. installatie .....	--	38	38
Cockpit - installatie .....	tot framenr. 9 347 686	39	--
Cockpit - installatie .....	vanaf framenr. 9 347 687	40	--
Cockpit - installatie .....	--	41	41
Stuur - afdekplaatje - bel .....	42	42	42
Voetrem .....	43	43	43
Handles en bedieningskabels .....	44	--	--
Handles en bedieningskabels .....	tot framenr. 9 332 082	--	45
Gashandle en bedieningskabels ....	vanaf framenr. 9 332 083	--	46
Koppelingshandle en bedieningskabel	vanaf framenr. 9 332 083	--	47
Gashandle - remleiding .....	--	--	48
Koppelingshandle en bedieningskabels .....	--	--	49
Spatschermen - bevestigingen .....	50	50	51
Benzinetank - gereedschap-set - luchtpomp - beugel .....	52	52	52
Buddyseat - standaard - voetsteunen .....	53	--	--
Buddyseat - spoiler - standaard - voetsteunen .....	--	54	54
Toebehoren / Cockpit-bekleding .....	55	55	55

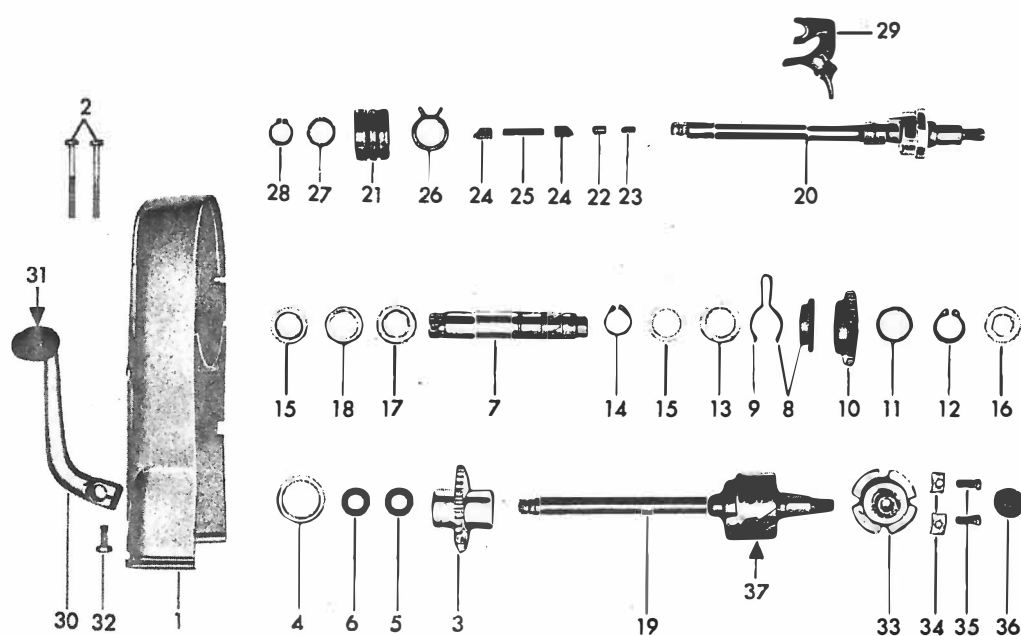

01.266.2

Afb.	Bestelnummer	Omschrijving	GTS	KS
1	280-01.255	Carterdeksel links zwart	1	1
2	DIN 84/500	Carterbout M 6x45	2	2
3	280-05.612	Tandwiel 30 t.	1	1
4	278-01.128	Afstandsbus 28,2x35x4	1	1
5	284-05.101	Dichtring	1	1
6	283-05.167	Oliekeerring 12x20x4	1	1
7	280-05.170	Kickstarteras	1	1
8	283-05.901	Meenemer met remveer	1	1
9	267-05.334	Remveer	1	1
10	281-05.162	Startertandwiel 31 t.	1	1
11	265-05.203	Tussenring 20x28x2	1	1
12	DIN 471/535	Borgring 20x1,75	1	1
13	265-05.255	Vulschijf 22,1x32x0,2		n.beh.
14	DIN 471/530	Borgring 20x1,2 tot motornr. 9 827 703	2	2
14	DIN 471/535	Borgring 20x1,75 vanaf motornr. 9 827 704	2	2
15	267-05.310	Vulschijf 20,2x28x0,1		n.beh.
--	278-01.129	Vulschijf 20,2x28x0,2		n.beh.
--	278-01.130	Vulschijf 20,2x28x0,5		n.beh.
--	278-01.131	Vulschijf 20,2x28x1,0	1	1
16	265-05.245	Vulschijf 16,2x28x1,0	1	1
17	278-01.125	Vulschijf 20,5x31x1,0	1	1

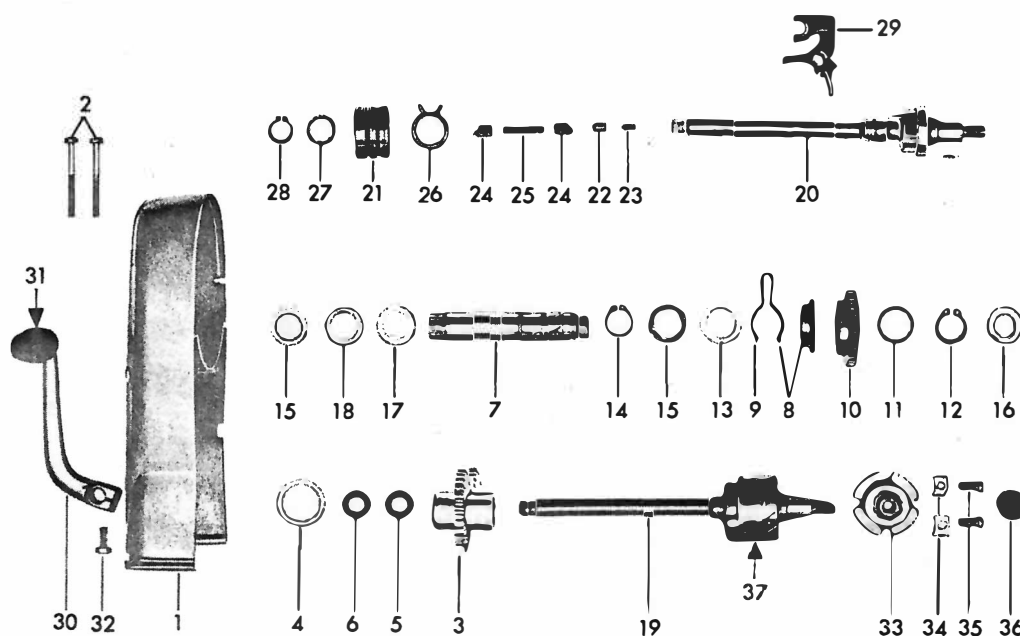

01.266.2

Afb.	Bestelnummer	Omschrijving	GTS	KS
18	278-01.131	Vulschijf 20,2x28x1,0	1	1
19	281-05.708	Voetschakelas compleet	1	1
20	267-05.654	Voetschakelas kaal	1	1
--	DIN 5402/300	Borgpen 3x27,8	1	1
21	281-05.137	Huls	1	1
22	267-05.125	Aanslagbout	1	1
23	267-05.126	Drukveer voor aanslagbout	1	1
--	DIN 660/345	Niet 2,6x6	1	1
24	267-05.586	Schakelpal	2	2
25	267-05.585	Drukveer voor schakelpal	1	1
26	278-05.100	Terugslagveer	1	1
27	267-05.244	Vulschijf 16,2x22,8x1,0	n.beh.	
28	DIN 471/350	Borgring 16x1	1	1
29	267-05.633	Schakelvork	1	1
30	283-05.716	Voetschakelpedaal compleet	1	1
31	616 z 25	Rubber	1	1
32	DIN 933/346	Bout M 6x16	1	1
33	267-05.112	Instelplaat	1	1
34	267-05.113	Onderlegplaatje	2	2
35	DIN 920/430	Bout voor instelplaat M 6x16	2	2
36	267-05.130	Rubber dop	1	1
37	281-05.158	Schakelhuls	1	1

Koelingskap - schoepenrad

CS

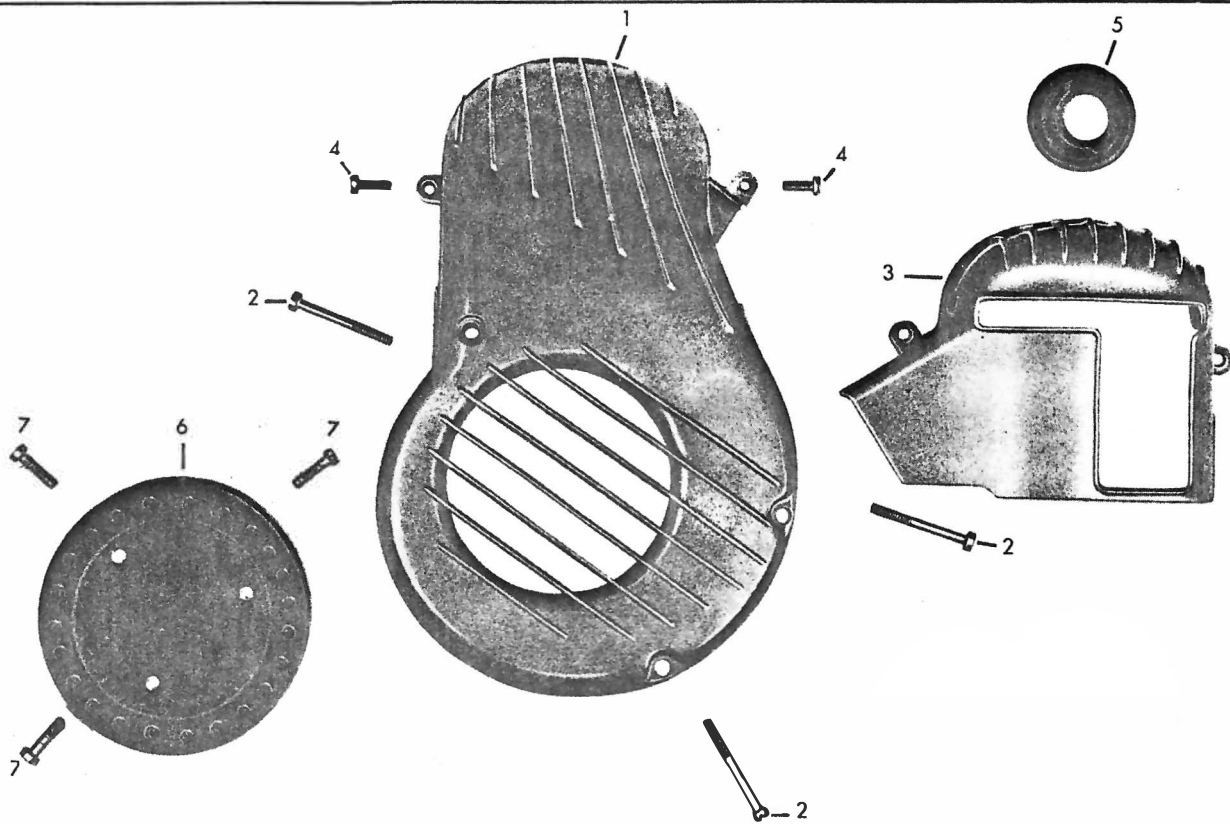

Afb.	Bestelnummer	Omschrijving	CS
1	266-01.209	Koelingskap	1
2	DIN 84/500	Bout BM 6x45	3
3	266-01.602	Kleine koelingskap	1
-	266-01.217	Rubbertje voor koelingskap	2
4	DIN 84/350	Bout AM 5x14	2
5	266-01.214	Rubber	1
6	266-07.603	Schoepenrad	1
-	284-07.116	Vulschijf 6,1x11,8x1,25	3
7	DIN 84/430	Bout AM 6x12	3
-	266-01.211	Afsluitdeksel	1

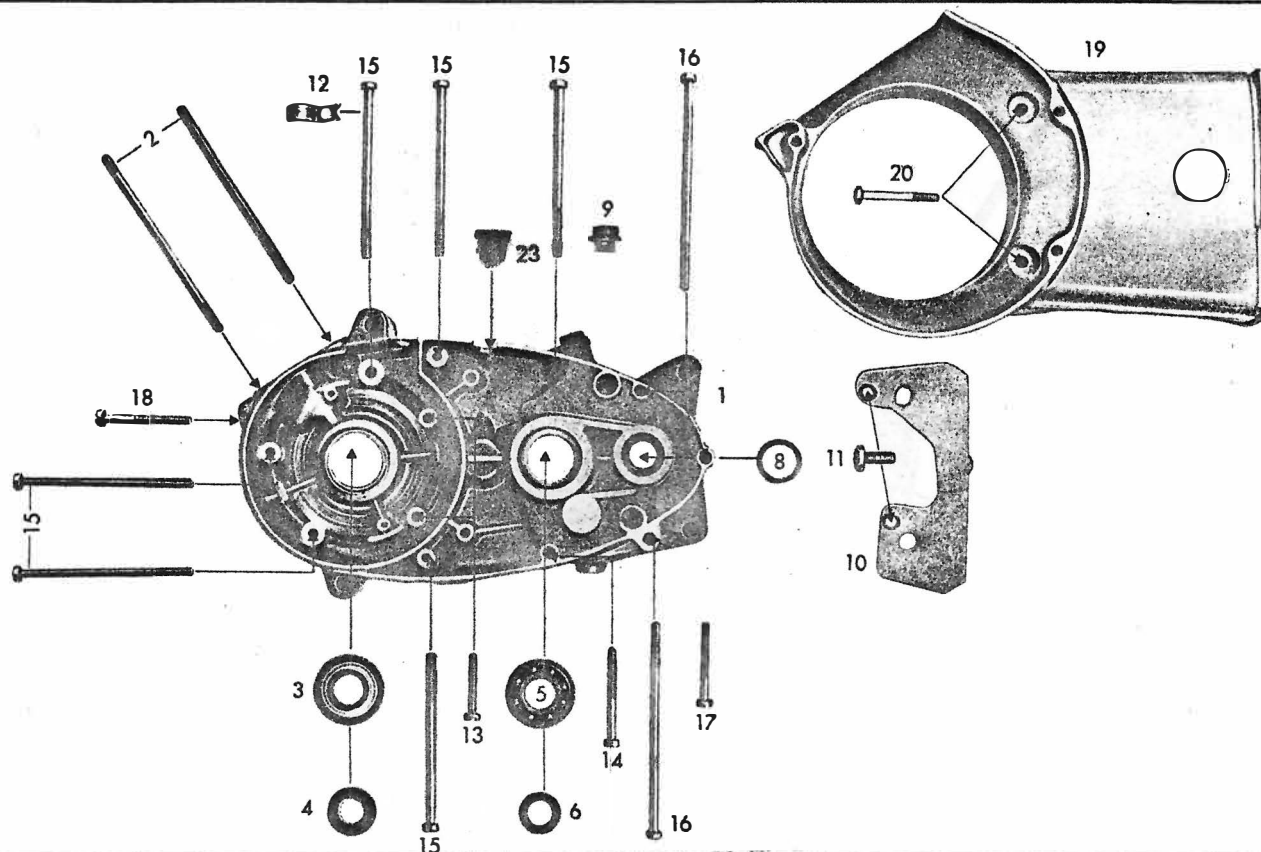

Afb.	Bestelnummer	Omschrijving	CS
1	265-01.908	Carterhelft links kaal	1
-	265-01.117	Carterpakking	1
2	265-01.100	Tapeind M 7x120	2
3	DIN 625/500	Kogellager 6203 Z/C3 17x40x12	1
4	277-01.136	Simmerring 17x28x7	1
5	DIN 625/470	Kogellager 6203 C3 17x40x12	1
6	265-01.135	Simmerring 16x24x7	1
8	265-01.136	Simmerring 16x22x3	1
9	281-01.135	Olievulschroef	1
10	266-01.208	Tussenplaat	1
11	DIN 964/430	Bout M 5x10	2
12	276-01.145	Kabelklem	1
13	DIN 84/480	Carterbout AM 6x35	2
14	DIN 84/540	Carterbout BM 6x65/20	1
15	DIN 84/590	Carterbout BM 6x98/25	6
16	DIN 84/610	Carterbout BM 6x120/25	3
17	DIN 84/510	Carterbout BM 6x50	1
18	DIN 84/500	Carterbout BM 6x45	1
19	267-01.137	Carterdeksel links kaal	1
20	DIN 931/320	Bout M 6x45	2
23	284-01.100	Afsluitkap	1

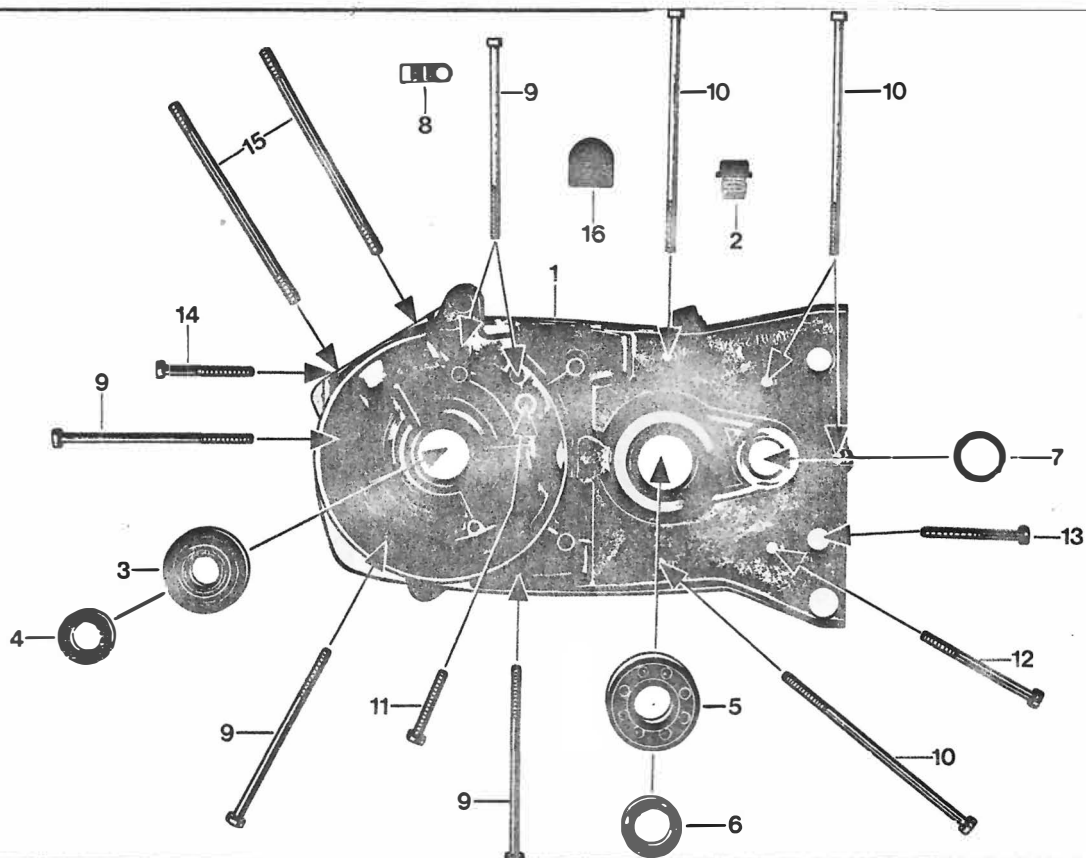

01.280.2

Afb.	Bestelnummer	Omschrijving	GTS	KS
1+2	276-01.910	Carterhelft links	1	1
2	281-01.135	Olievulschroef	1	1
-	265-01.117	Carterpakking	1	1
3	DIN 625/500	Kogellager 6203 Z/C3 17x40x12	1	1
4	277-01.136	Simmerring 17 x28x7	1	1
5	DIN 625/515	Kogellager 6204 C3 20x47x14	1	1
6	285-01.183	Simmerring 20x30x7	1	1
7	285-01.153	Simmerring 20x26x4	1	1
8	276-01.145	Kabelklem	1	1
9	DIN 84/590	Carterbout BM 6x98/25	5	5
10	DIN 84/610	Carterbout BM 6x120/25	4	4
11	DIN 84/480	Carterbout AM 6x35	2	2
12	DIN 84/540	Carterbout BM 6x65/20	1	1
13	DIN 84/510	Carterbout BM 6x50	1	1
14	DIN 84/500	Carterbout BM 6x45	1	1
15	265-01.100	Tapeind M 7x120 $\phi$ 6,35	1	1
15	278-01.137	Tapeind M 7x120 $\phi$ 8	1	1
16	284-01.100	Afsluitkap	1	1



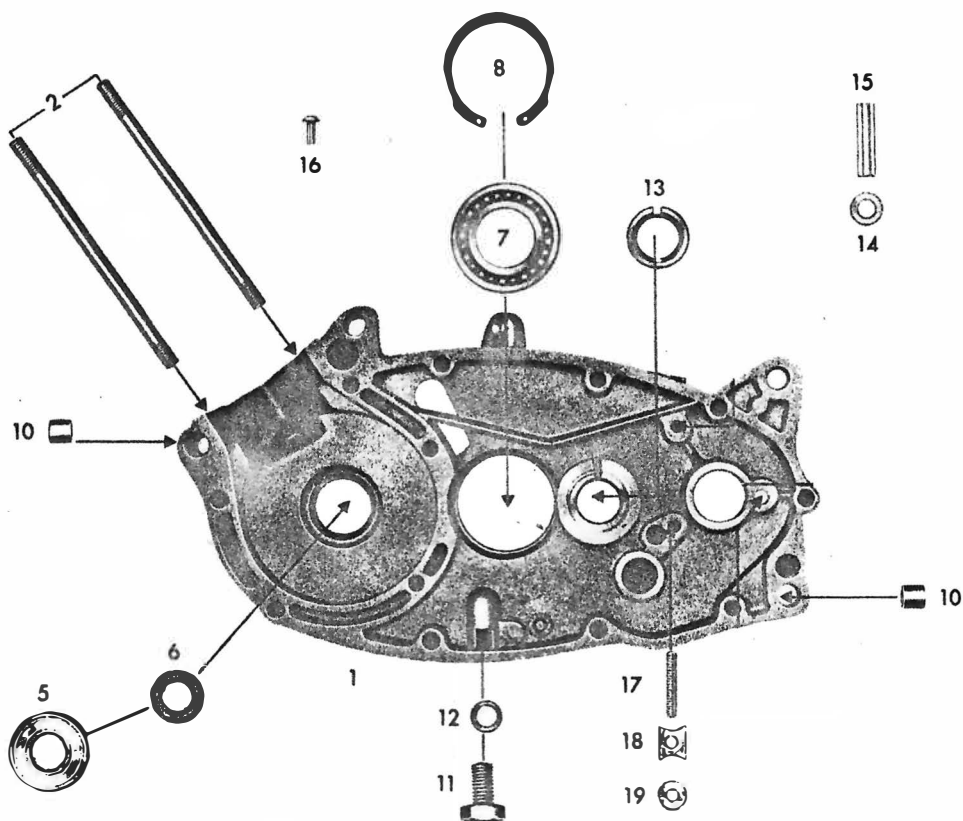

Afb.	Bestelnummer	Omschrijving	CS
1	265-01.907	Carterhelft rechts kaal	1
-	265-01.118	Carterpakking	1
2	265-01.100	Tapeind M 7x120	2
5	DIN 625/440	Kogellager 6202 Z/C3 15x35x11	1
6	255-01.144	Simmerring 15x24x7	1
7	DIN 625/695	Kogellager 16005 C3 25x37x8	1
8	276-01.154	Borgring J 47x1,75	1
10	M 181 z 138	Pasbus	4
11	DIN 933/670	Olie-aftapbout M 10x18	1
12	DIN 7603/410	Afdichtring A 10x13,5	1
13	265-01.102	Lagerbus	1
14	265-01.105	Bronzen lager	1
15	265-01.104	Afstandsbus	1
16	DIN 1476/650	Niet 5x15	1
17	DIN 551/625	Tapeind M 6x40	1
18	DIN 439/400	Moer BM 6	1
19	265-01.138	Borgplaatje	1
--	DIN 1476/200	Niet 2x3	3
--	265-01.143	Borgplaatje	1
--	DIN 6797/400	Vulschijf A 6,4	1
--	DIN 933/346	Bout M 6x16	1

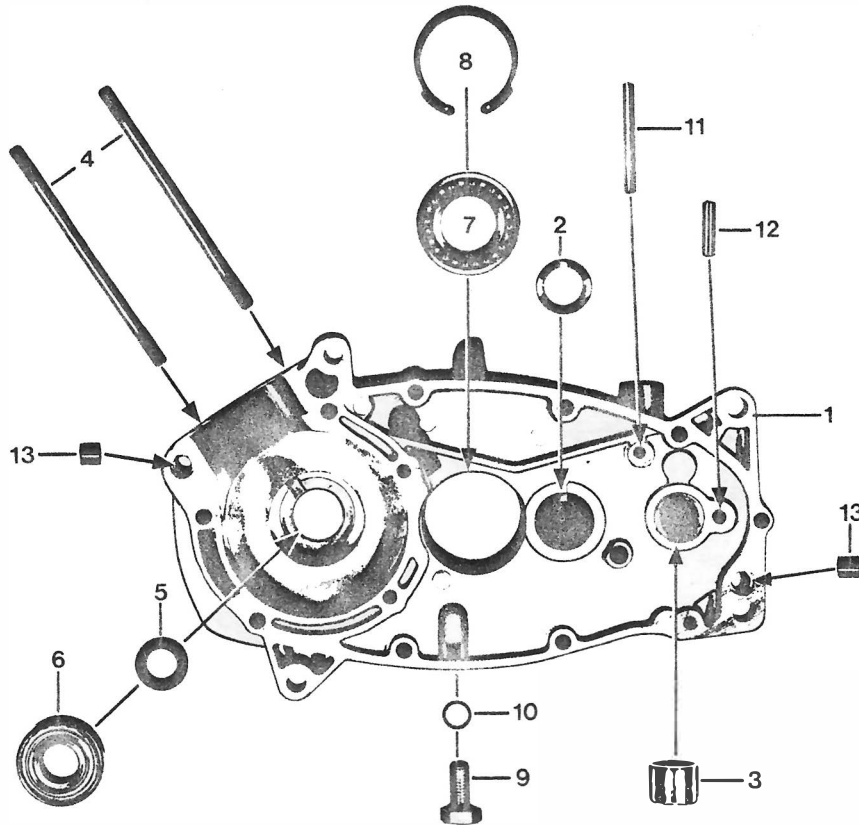

01.280.1

Afb.	Bestelnummer	Omschrijving	GTS	KS
1-3	280-01.903	Carterhelft rechts kaal	1	1
2	265-01.102	Lagerbus $\varnothing 18$	1	1
3	267-01.128	Lagerbus $\varnothing 16$ tot motornr. 9 712 484	1	1
3	267-01.153	Lagerbus $\varnothing 16$ vanaf motornr. 9 712 485	1	1
-	265-01.118	Carterpakking	1	1
4	265-01.100	Tapeind M 7x120	2	2
5	255-01.144	Simmerring 15x24x7	1	1
6	DIN 625/650	Kogellager 6302 Z/C3 15x42x13	1	1
7	DIN 625/695	Kogellager 16005 C3 25x47x8	1	1
8	276-01.154	Borgring J 47x1,75	1	1
9	DIN 933/670	Olie-aftapbout M 10x18	1	1
10	DIN 7603/410	Afdichtring A 10x13,5	1	1
11	DIN 1481/620	Huls 5x45	1	1
12	267-05.129	Stift 6x24	1	1
13	M 181 z 138	Pasbus	4	4
--	DIN 1476/200	Niet 2x3	3	3

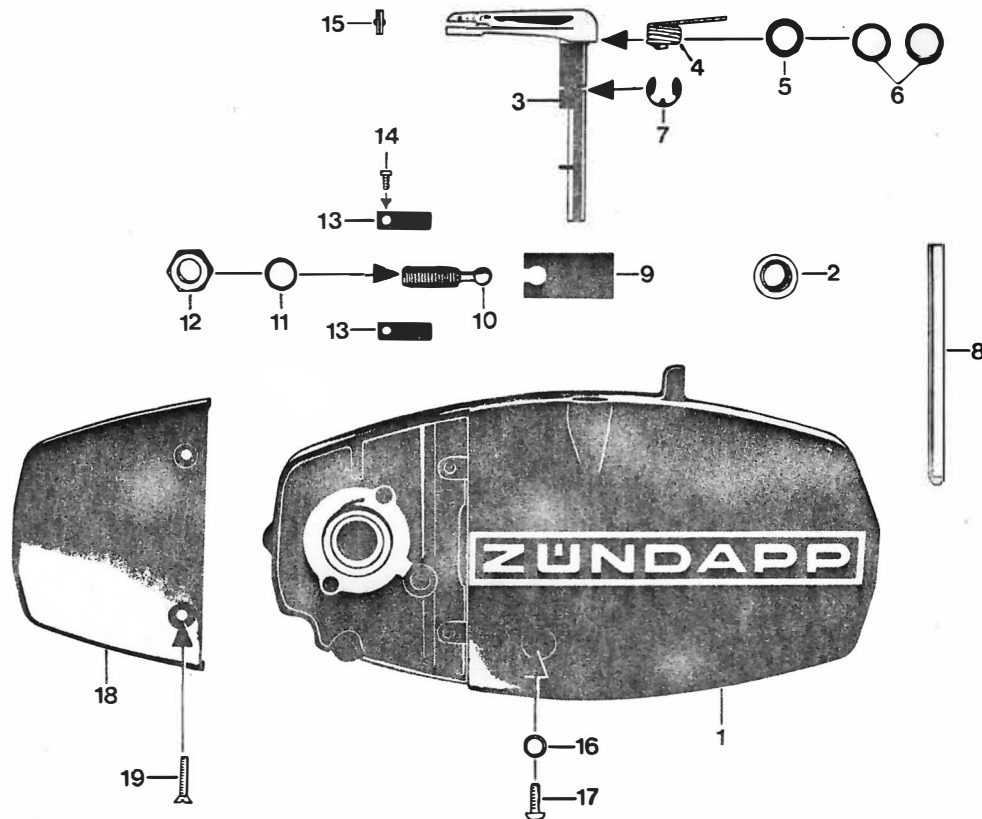

01.278.3

Afb.	Bestelnummer	Omschrijving	CS	GTS	KS
1	278-01.144	Carterdeksel rechts kaal zwart	-	1	1
-	265-01.151	Carterdeksel rechts kaal	1	-	-
2	265-01.136	Simmerring 16x22x3	1	-	-
3	265-06.602	Koppelingshevel	1	1	1
4	265-06.112	Veer	1	1	1
5	405-15.388	O-Ring $\phi$ 11x2,5	1	1	1
6	281-06.114	Vulschijf 0,2	1	1	1
-	281-06.115	Vulschijf 0,5		n. beh.	
7	DIN 6799/500	Borgveer 8	1	1	1
8	276-05.172	Geleidestift $\phi$ 8x95,5	-	1	1
9	265-06.104	Koppelingstong	1	1	1
10	265-06.106	Stelschroef	1	1	1
11	DIN 7603/410	Afdichtring A 10x13,5	1	1	1
12	DIN 936/560	Moer M 10x1	1	1	1
13	265-06.109	Bladveer	2	2	2
14	DIN 84/250	Bout AM 4x6	2	2	2
15	DIN 1481/260	Huls 3x12	1	1	1
16	DIN 7603/200	Afdichtring A 6x10	1	1	1
17	DIN 85/500	Bout AM 6x12	1	1	1
18	284-01.176	Aansluitkap	-	1	1
--	265-01.115	Aansluitkap	1	-	-
19	DIN 964/440	Bout AM 5x20	2	2	2

Koppeling

CS GTS KS

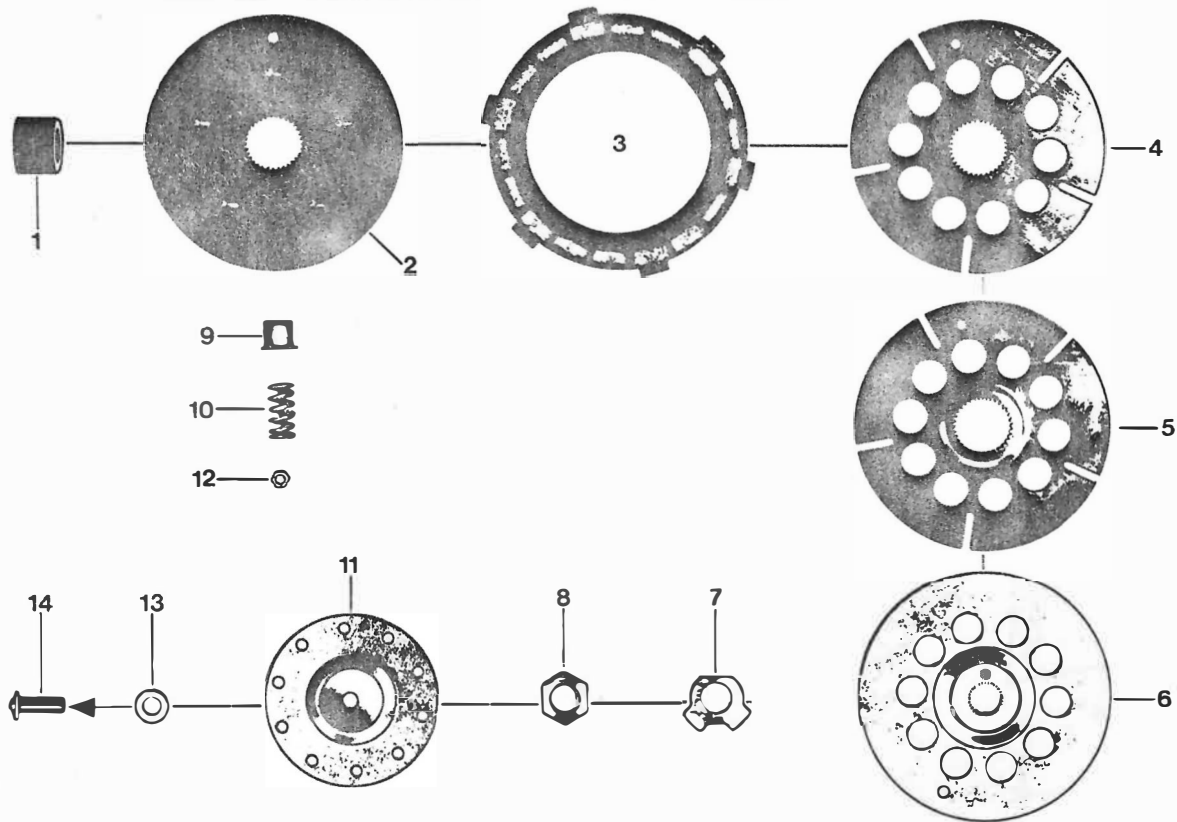

06.265.1

Afb.	Bestelnummer	Omschrijving	CS	GTS	KS
1	265-06.201	Koppelingskern	1	1	1
2	265-06.606	Grondplaat	1	1	1
3	280-06.100	Koppelingsplaat	4	4	4
4	265-06.130	Stalen koppelingsplaat	2	2	2
5	265-06.131	Stalen koppelingsplaat	1	1	1
6	265-06.127	Dekplaat	1	1	1
7	284-06.104	Borgplaatje	1	1	1
8	265-06.202	Moer	1	1	1
9	261-06.155	Veerhoedje	10	10	10
10	281-06.101	Koppelingsveer	10	10	10
11	265-06.216	Drukplaat	1	1	1
12	DIN 934/280	Moer M 4	5	5	5
13	265-05.296	Vulschijf 6,1x11,8x0,8	1	1	1
--	265-05.295	Vulschijf 6,1x11,8x0,4		n. beh.	
--	265-05.294	Vulschijf 6,1x11,8x0,2		n. beh.	
14	247-05.233	Koppelingsdrukstift	1	1	1

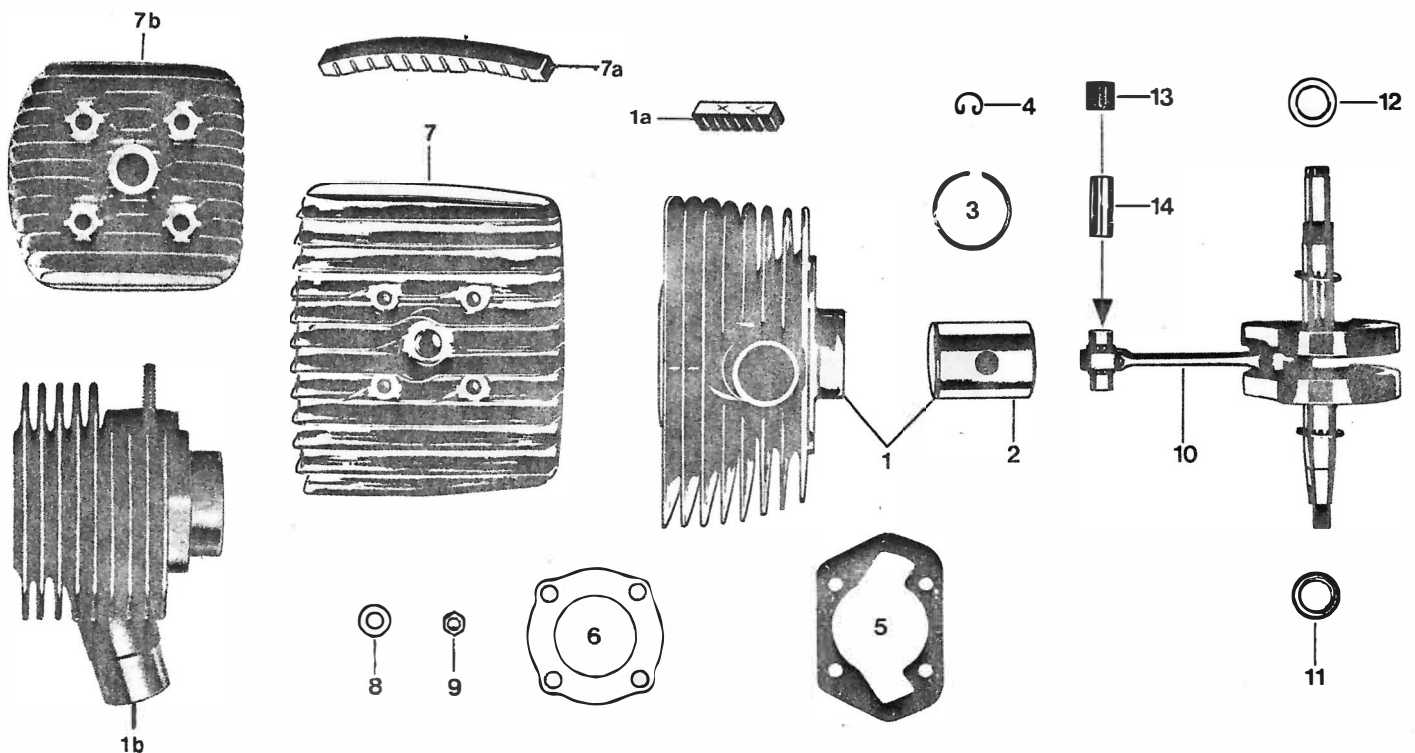

Afb.	Bestelnummer	Omschrijving	CS	GTS	KS
1	278-02.721	*Cylinder met zuiger	-	1	1
1	280-02.719	**Cylinder met zuiger	-	1	1
1a	250-02.119	**Rubber	-	4	4
1b	266-02.700	Cylinder met zuiger	1	-	-
2	278-02.729	Zuiger compleet	1	1	1
3	248-02.107	Zuigerveer 39x1,5	1	1	1
4	DIN 73123/500	Zuigerpenborgveer A 12	2	2	2
5	276-02.219	*Cylindervoetpakking	-	1	1
5	284-02.165	**Cylindervoetpakking	-	1	1
5	265-02.110	Cylindervoetpakking	1	-	-
6	278-02.109	Cylinderkoppakking	-	1	1
6	284-02.158	Cylinderkoppakking	1	-	-
7	278-02.107	*Cylinderkop	-	1	1
7	278-02.732	**Cylinderkop	-	1	1
7a	278-02.116	Rubber	-	2	2
7b	265-02.201	Cylinderkop	1	-	-
8	265-02.120	Sluitring	4	4	4
9	DIN 934/440	Moer M 7	4	4	4
10	278-03.902	Krukas compleet	1	1	1
--	278-03.903	Drijfset	1	1	1
11	277-03.111	Facettenschijf 17,1x24x1,5x2	1	1	1
--	265-05.177	Vulschijf 17,1x24x0,1	n.	beh.	
--	265-05.176	Vulschijf 17,1x24x0,2	n.	beh.	
--	265-05.175	Vulschijf 17,1x24x0,5	n.	beh.	
--	265-05.179	Vulschijf 17,1x24x0,8	n.	beh.	
12	277-03.115	Facettenschijf 15,1x24x1,5x2	1	1	1
--	261-05.144	Vulschijf 15,1x24x0,1	n.	beh.	
--	261-05.137	Vulschijf 15,1x24x0,2	n.	beh.	
--	261-05.138	Vulschijf 15,1x24x0,5	n.	beh.	
--	261-05.132	Vulschijf 15,1x24x0,8	n.	beh.	
13	258-03.600	Zuiger naaldlager 12x15x14,8	1	1	1
14	M 121 z 605	Zuigerpen $\varnothing$ 12	1	1	1

\*tot motornr. 9 810 635

\*\*vanaf motornr. 9 810 636

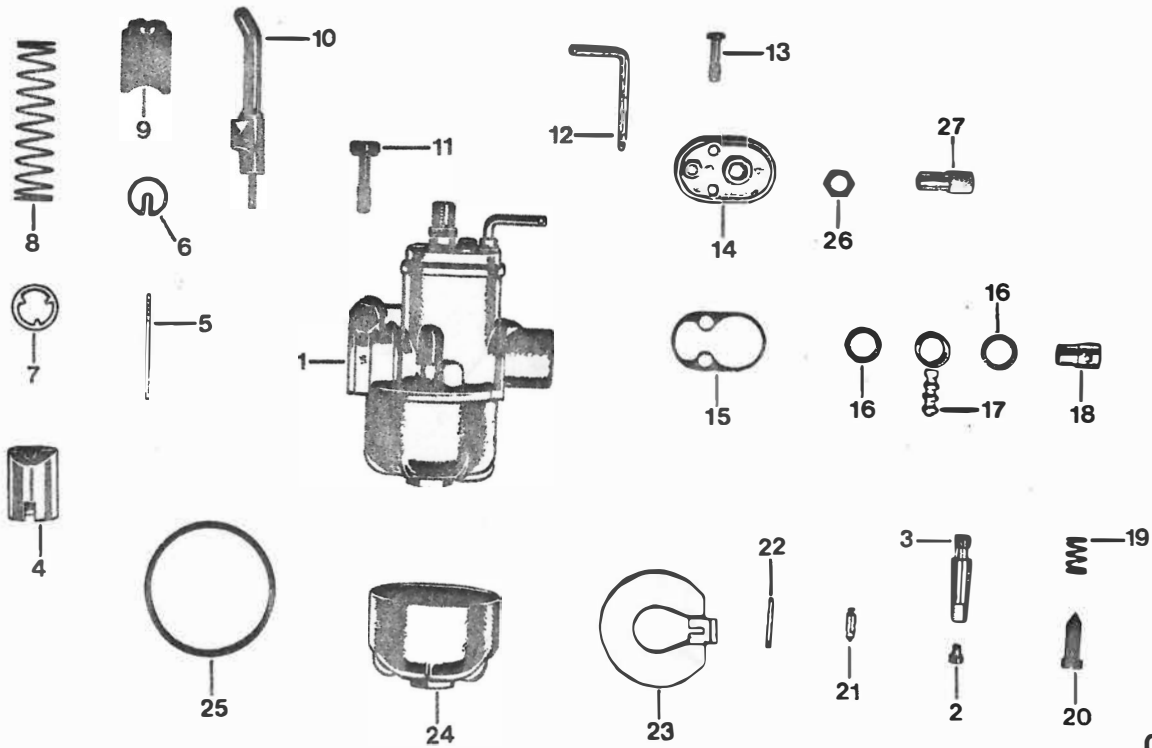

04.278.1

Afb.	Bestelnummer	Omschrijving	CS
1	266-04.731	Carburateur kpl. 1/10/139	1
2	276-04.924	Hoofdsproeier no. 58	n.beh.
-	248-04.908	Hoofdsproeier no. 60	1
-	248-04.900	Hoofdsproeier no. 62	n.beh.
3	248-04.911	Naaldsproeier no. 2,12	n.beh.
-	266-04.910	Naaldsproeier no. 2,15	1
-	278-04.904	Naaldsproeier no. 2,17	n.beh.
4	278-04.924	Gasschuif	1
5	267-04.903	Sproeiernaald	1
6	265-04.907	Sproeiernaaldhouder	1
7	265-04.912	Plaatje	1
8	265-04.909	Gasschuifveer	1
9	265-04.908	Startschuif	1
10	248-04.917	Tickler	1
11	266-04.909	Klemschroef	1
12	249-04.901	Drukstift	1
13	267-04.960	Boutje	2
14	265-04.900	Mengkamerdeksel	1
15	265-04.910	Mengkamerdeksel-pakking	1
16	267-04.946	Afdichtring	2
17	251-04.933	Slangnippel	1
18	251-04.934	Boutje	1
19	251-04.922	Stelschroefveer	1
20	251-04.921	Luchtreghelschroef	1
21	267-04.961	Vlotternaald	1
22	267-04.941	Scharnierstift	1
23	267-04.962	Vlotter	1
24	267-04.922	Vlotterkamer	1
25	267-04.947	Pakking	1
26	251-04.927	Moer voor stelschroef	1
27	400-17.126	Kabelstelschroef	1

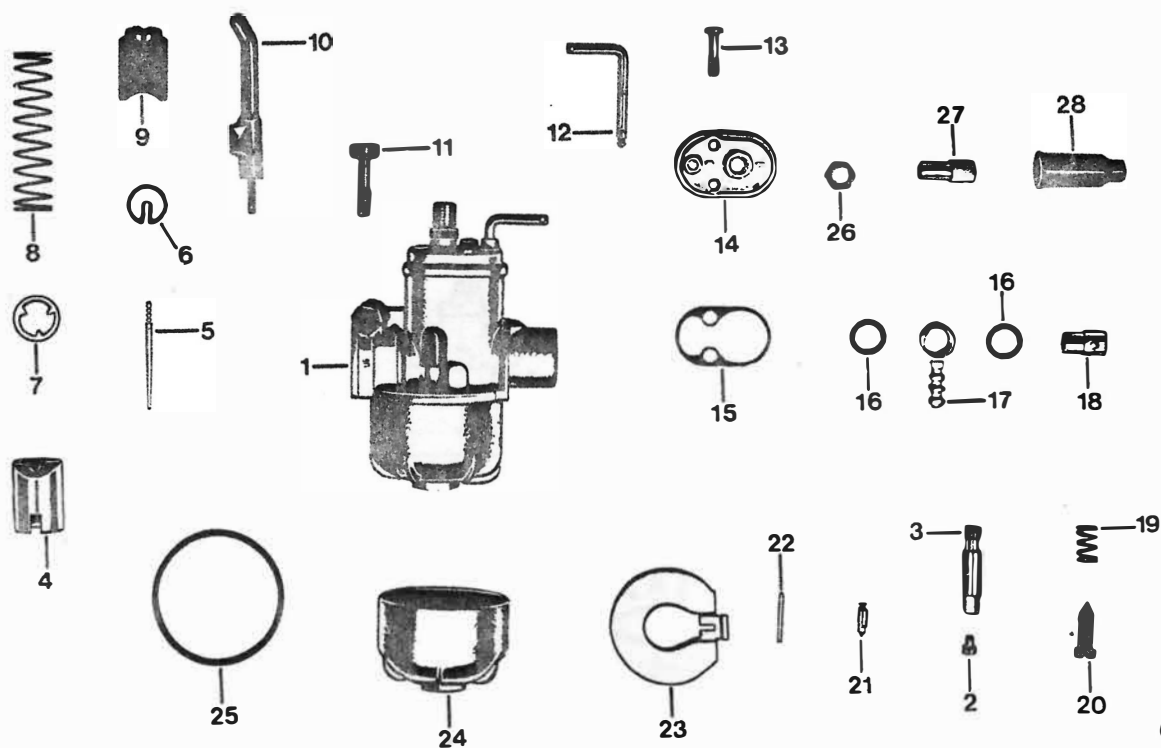

04.278.1

Afb.	Bestelnummer	Omschrijving	GTS	KS
1	280-04.713	Carburateur kpl. 1/10/140	1	1
2	248-04.909	Hoofdsproeier no. 56	n. beh.	
-	276-04.924	Hoofdsproeier no. 58	1	1
-	248-04.908	Hoofdsproeier no. 60	n. beh.	
3	248-04.911	Naaldsproeier no. 2,12	n. beh.	
-	266-04.910	Naaldsproeier no. 2,15	1	1
-	278-04.904	Naaldsproeier no. 2.17	n. beh.	
4	278-04.910	Gasschuif	1	1
5	248-04.914	Sproeiernaald	1	1
6	265-04.907	Sproeiernaaldhouder	1	1
7	265-04.912	Plaatje	1	1
8	265-04.909	Gasschuifveer	1	1
9	265-04.908	Startschuif	1	1
10	248-04.917	Tickler	1	1
11	266-04.909	Klemschroef	1	1
12	249-04.901	Drukstift	1	1
13	267-04.960	Boutje	2	2
14	265-04.900	Mengkamerdeksel	1	1
15	265-04.910	Mengkamerdeksel-pakking	1	1
16	267-04.946	Afdichtring	2	2
17	251-04.933	Slangnippel	1	1
18	251-04.934	Boutje	1	1
19	251-04.922	Stelschroefveer	1	1
20	251-04.921	Luchtregelschroef	1	1
21	267-04.961	Vlotternaald	1	1
22	267-04.941	Scharnierstift	1	1
23	267-04.962	Vlotter	1	1
24	267-04.922	Vlotterkamer	1	1
25	267-04.947	Pakking	1	1
26	251-04.927	Moer voor stelschroef	1	1
27	400-17.126	Kabelstelschroef	1	1
28	517-17.111	Rubber tule	1	1

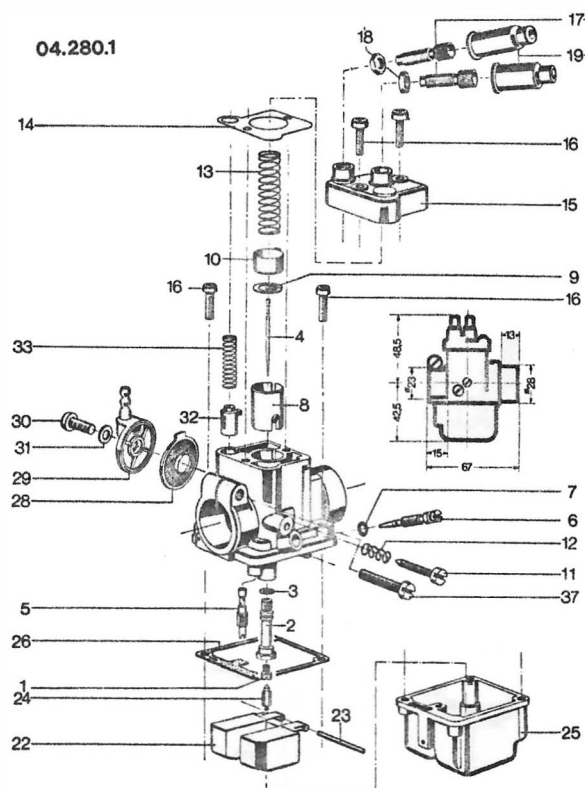

Afb,	Bestelnummer	Omschrijving	GTS	KS
-	278-04.758	Carburateur kpl. 17/10/103	1	1
1	278-04.964	Hoofdsproeier no. 44	n.	beh.
1	278-04.965	Hoofdsproeier no. 46	n.	beh.
1	278-04.966	Hoofdsproeier no. 48	1	1
1	278-04.967	Hoofdsproeier no. 50	n.	beh.
1	278-04.968	Hoofdsproeier no. 52	n.	beh.
2	278-04.947	Naaldsproeier no. 2,04	n.	beh.
2	278-04.948	Naaldsproeier no. 2,06	n.	beh.
2	278-04.949	Naaldsproeier no. 2,08	1	1
2	278-04.950	Naaldsproeier no. 2,10	n.	beh.
2	278-04.951	Naaldsproeier no. 2,12	n.	beh.
3	278-04.925	Afdichtring	1	1
4	248-04.914	Sproeiernaald	1	1
5	278-04.970	Stat. sproeier no. 36	n.	beh.
5	278-04.971	Stat. sproeier no. 40	1	1
6	278-04.926	Luchtregelschroef	1	1
7	278-04.927	Afdichtring	1	1
8	278-04.934	Gasschuif	1	1
9	265-04.907	Sproeiernaaldhouder	1	1
10	278-04.935	Gasschuifgeleider	1	1
11	278-04.928	Luchtregelschroef	1	1



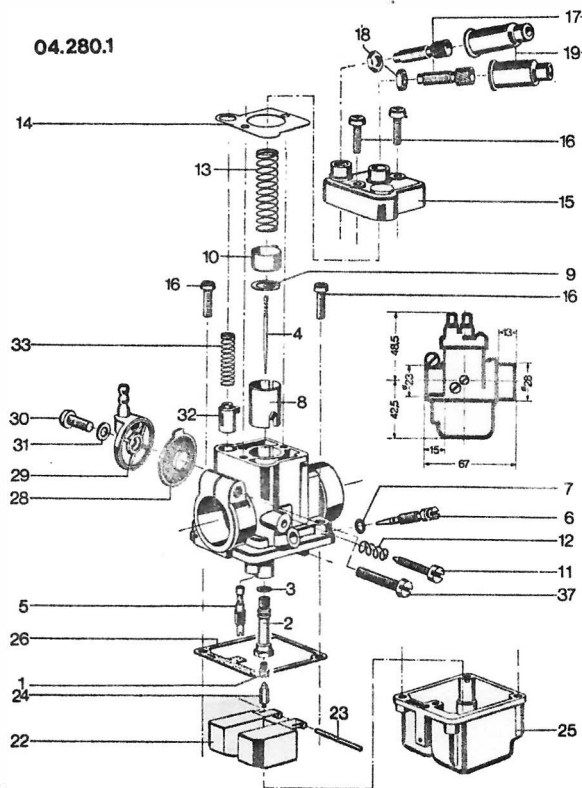

Afb.	Bestelnummer	Omschrijving	GTS	KS
12	278-04.929	Veer	1	1
13	278-04.936	Gasschuifveer	1	1
14	278-04.940	Mengkamerdeksel-pakking	1	1
15	278-04.939	Mengkamerdeksel	1	1
16	278-04.946	Boutje	4	4
17	400-17.126	Kabelstelschroef	2	2
18	251-04.927	Moer voor stelschroef	2	2
19	517-17.111	Rubber tule	2	2
22	278-04.942	Vlotter	1	1
23	278-04.943	Scharnierstift	1	1
24	267-04.961	Vlotternaald	1	1
25	278-04.945	Vlotterkamer	1	1
26	278-04.944	Pakking	1	1
28	278-04.931	Filter	1	1
29	278-04.932	Filterdeksel	1	1
30	278-04.969	Boutje	1	1
31	304-06.905	Afdichtring	1	1
32	278-04.937	Startschuif	1	1
33	278-04.938	Startschuifveer	1	1
37	278-04.930	Klemschroef	1	1

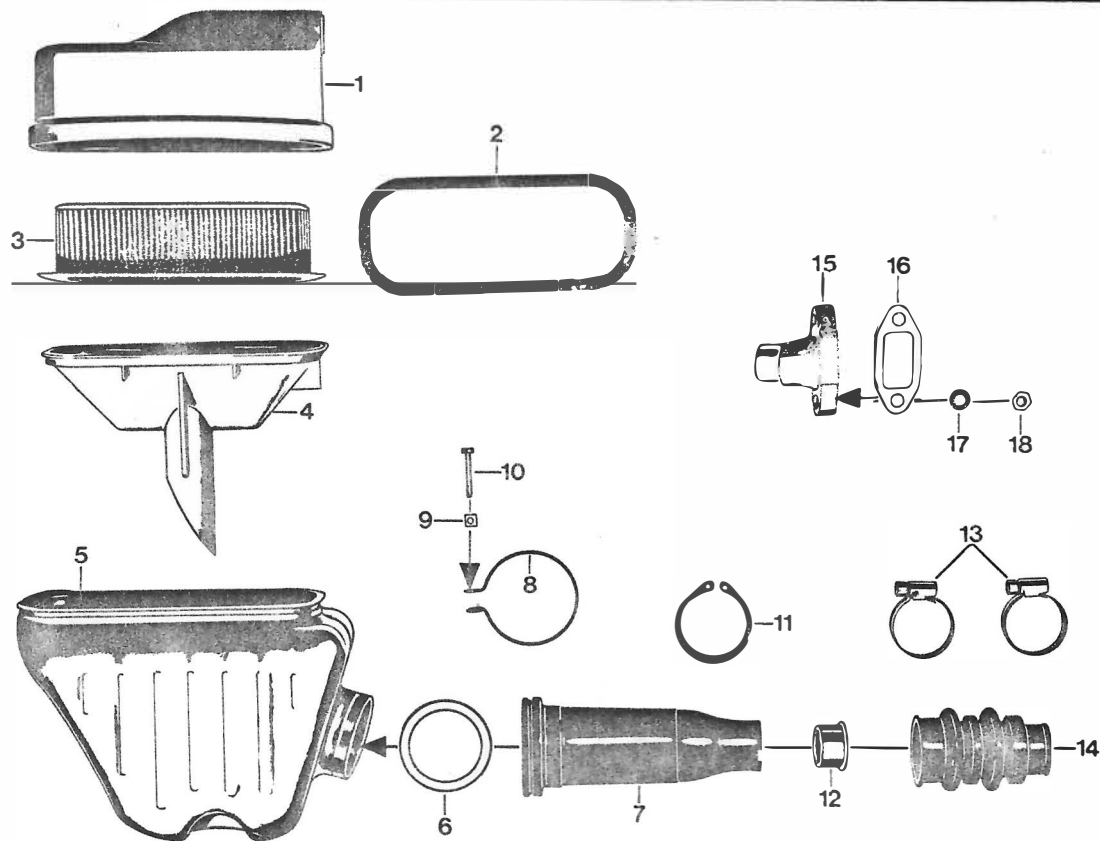

04.278.2

Afb.	Bestelnummer	Omschrijving	CS	GTS	KS
1	517-10.152	Kap voor geruisdemper	1	1	1
2	517-10.142	Afdichtring	1	1	1
3	517-10.604	Microfilter	1	1	1
4	517-10.133	Aanzuigtrechter	1	1	1
5	529-10.130	Geruisdemper	1	1	1
6	517-10.123	Versterkingsring	1	1	1
7	529-10.137	Luchttrechter	1	1	1
8	517-10.131	Spanveer	1	1	1
9	DIN 562/500	Moer M 4	1	1	1
10	DIN 84/310	Bout AM 4x25	1	1	1
11	DIN 471/778	Borgveer 40x1,75	1	1	1
12	280-04.107	Aanzuigbus $\varnothing$ 24,5	1	1	1
13	DIN 3017/370	Klemring LA 20-32	2	1	1
13	DIN 3017/390	Klemring LA 25-40	1	2	2
14	278-04.112	Harmonicarubber	1	-	-
14	280-04.106	*Harmonicarubber	-	1	1
14	278-04.136	**Harmonicarubber	-	1	1
15	266-04.108	Aanzuigflens	1	-	-
15	280-04.104	*Aanzuigflens	-	1	1
15	278-04.135	**Aanzuigflens	-	1	1
16	267-04.113	Aanzuigpakking	1	-	-
16	283-04.111	*Aanzuigpakking	-	1	1
16	280-04.118	**Aanzuigpakking	-	1	1
17	DIN 433/400	Vulschijf 6,4	2	2	2
18	DIN 934/410	Moer M 6	2	2	2

\*voor GTS, KS tot motornr. 9829555

\*\*voor GTS, KS vanaf motornr. 9829556

## Schakelhevel - schakelvork - trapas

CS

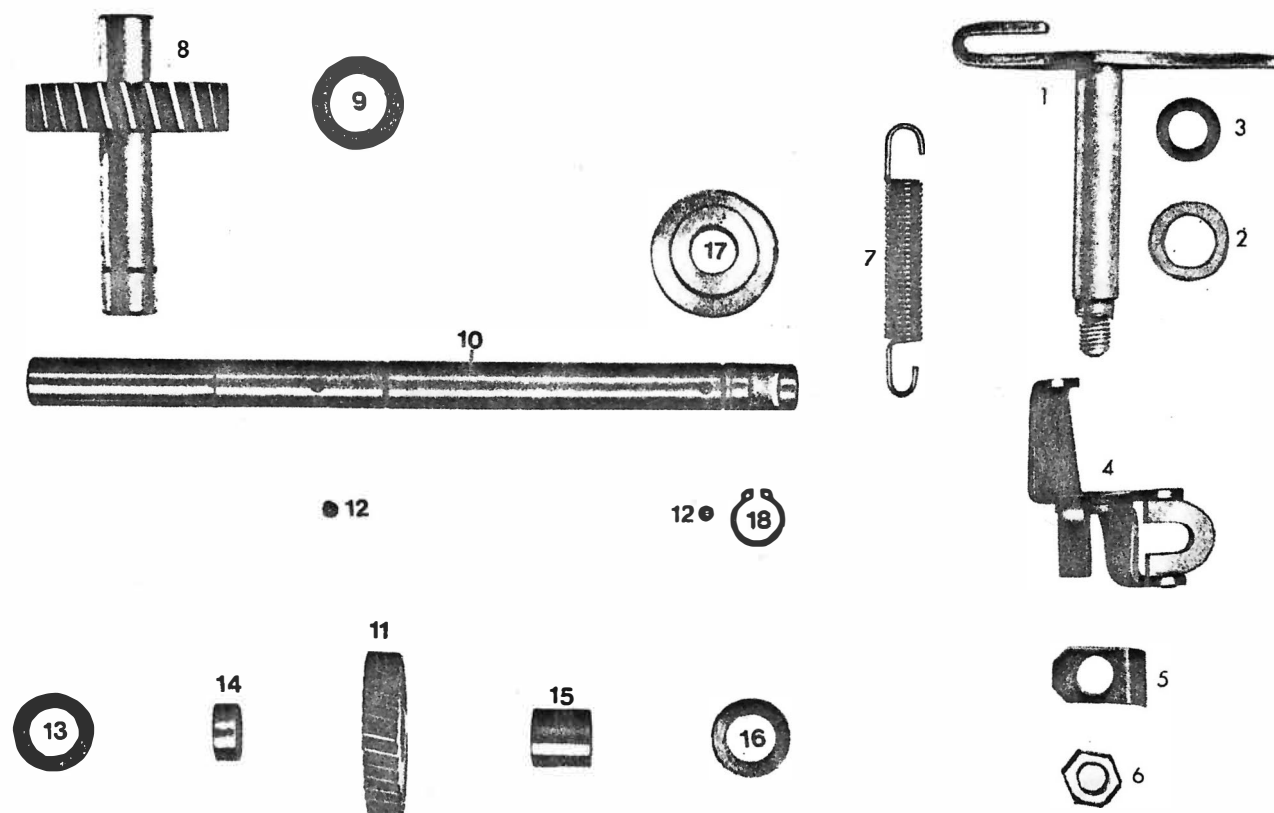

Afb.	Bestelnummer	Omschrijving	CS
1	265-05.612	Schakelhevel	1
2	278-05.165	Vulschijf 9,2x18,0x1,5	1
-	265-05.156	Vulschijf 9,2x18,1x1,5	1
3	265-05.252	Ring	1
4	265-05.613	Schakelvork	1
5	265-05.184	Borgplaatje	1
6	DIN 934/440	Moer M 7	1
7	265-05.118	Trekveer	1
8	265-05.625	Tussenas met tandwiel kpl.	1
9	261-05.242	Vulschijf 18x20x0,5	1
-	261-05.241	Vulschijf 18x20x0,2	n.beh.
10	266-05.190	Trapas kaal	1
11	265-05.218	Trapastandwiel 35 tanden	1
12	DIN 5401/350	Kogel $\varnothing$ 5	4
13	265-05.241	Vulschijf 16,2x28x1,5	2
--	265-05.243	Vulschijf 16,2x28x0,2	n.beh.
--	265-05.244	Vulschijf 16,2x28x0,1	n.beh.
14	265-05.220	Afstandbus 16,2x20x8,5	1
15	265-05.221	Afstandbus 16,2x20x19,8	1
16	265-05.242	Vulschijf 16,2x20x0,5	n.beh.
17	266-05.191	Meenemer	1
18	DIN 471/230	Borgveer 12x1	1

Versnellingsbak - onderdelen - kettingwiel

CS

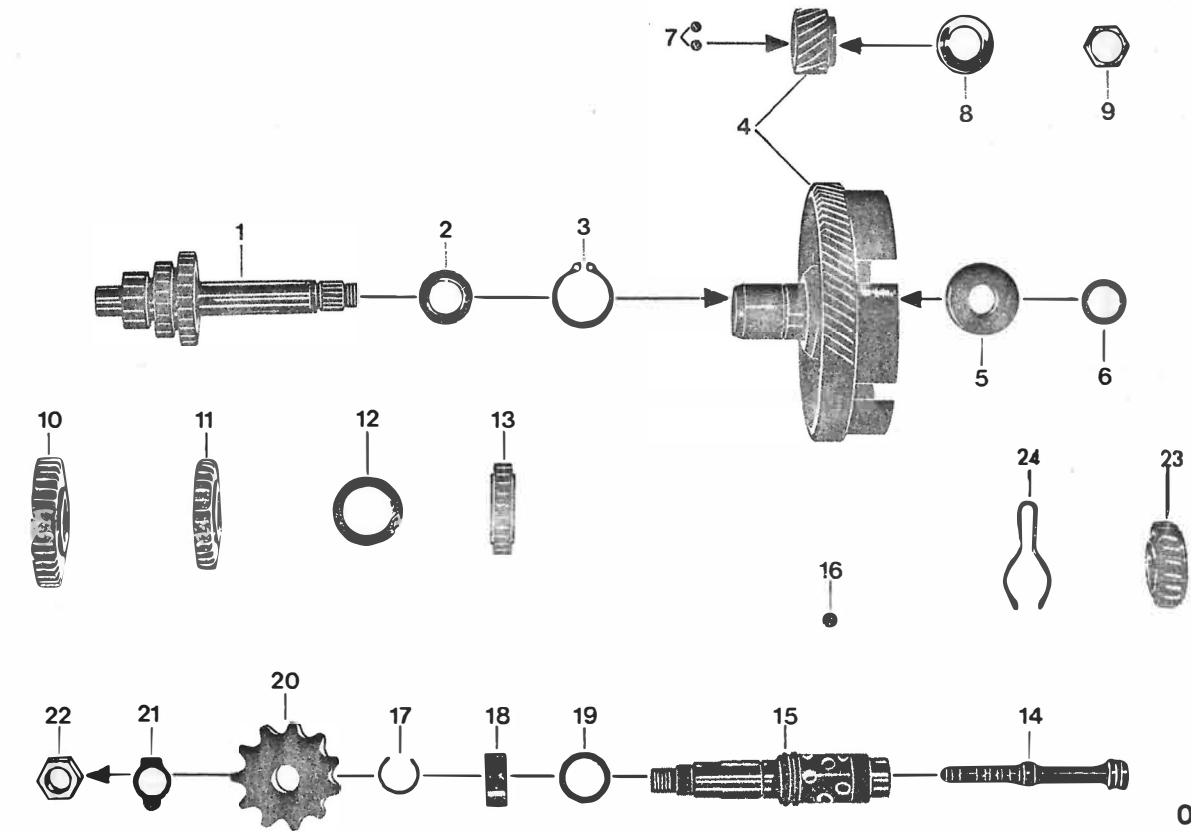

05.278.1

Afb.	Bestelnummer	Omschrijving	CS
1	266-05.157	Hoofdas	1
2	276-05.108	Vulschijf 15,1x17,8x24x1,0	n.beh.
-	276-05.110	Vulschijf 15,1x17,8x24x1,5	n.beh.
3	DIN 471/560	Borgveer 25x1,2	1
4	283-05.900	Koppelingshuis	1
5	DIN 625/215	Kogellager 6002 15x32x9	1
6	M 1301 z 459	Vulschijf 15,1x21x0,1	n.beh.
-	M 1301 z 451	Vulschijf 15,1x21x0,2	n.beh.
-	M 1301 z 452	Vulschijf 15,1x21x0,5	n.beh.
-	M 1301 z 450	Vulschijf 15,1x21x0,8	n.beh.
7	DIN 5401/350	Kogel $\phi$ 5	2
8	265-05.122	Vulschijf 15,2x25x0,8	1
9	265-05.123	Moer M 15x1 (SW 19)	1
10	266-05.110	Tandwiel 1e versnelling, 37 t.	1
11	266-05.113	Tandwiel 2e versnelling, 31 t.	1
12	265-05.256	Vulschijf 22,1x32x0,1	n.beh.
--	265-05.255	Vulschijf 22,1x32x0,2	n.beh.
13	266-05.263	Tandwiel 3e versnelling, 25 t.	1
14	265-05.105	Trekspie	1
15	265-05.101	Schakelas	1
16	278-05.101	Kogel $\phi$ 7	12
17	265-05.181	Borgring	1
18	267-05.549	Afstandbus	1
19	265-05.176	Vulschijf 17,1x23x0,2	n.beh.
--	265-05.177	Vulschijf 17,1x23x0,1	n.beh.
20	265-05.275	Kettingwiel 11 tanden	1
21	265-05.183	Borgplaatje voor kettingwiel	1
22	423-15.460	Moer M 12x1	1
23	265-05.900	Tandwiel met bus	1
24	265-05.164	Remveer	1

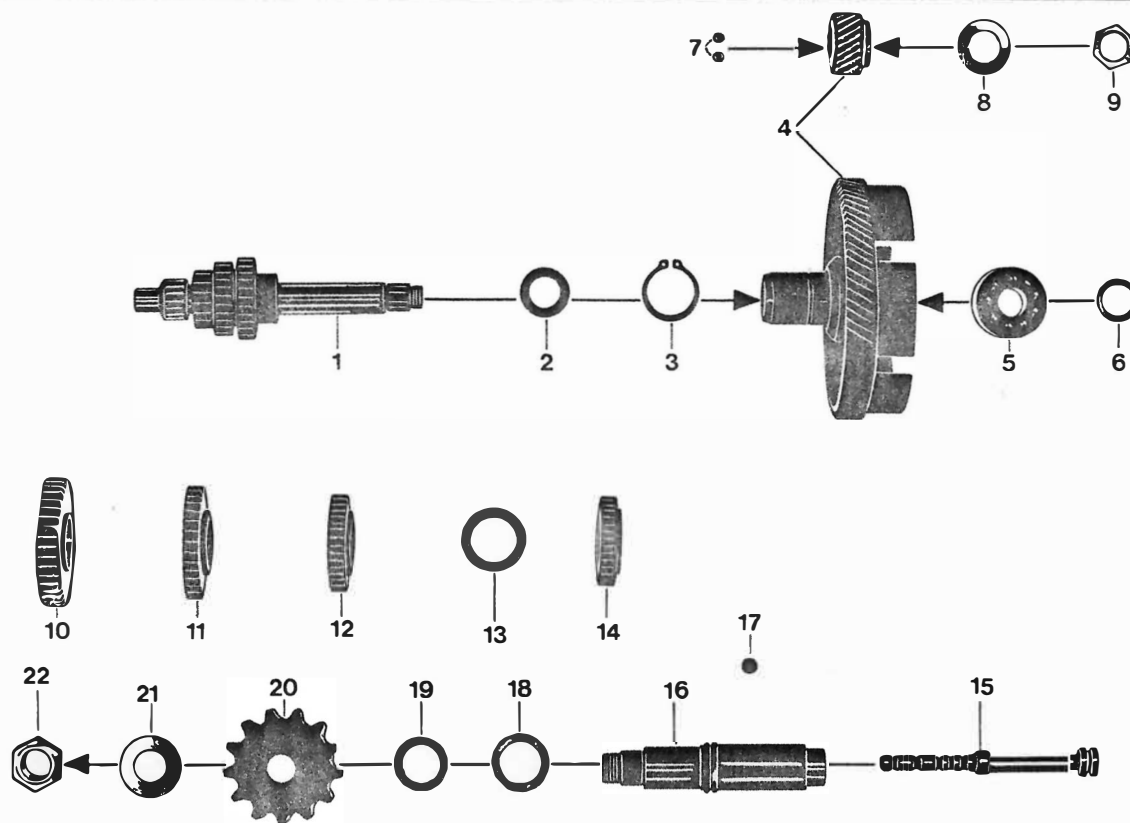

05.280.1

Afb.	Bestelnummer	Omschrijving	GTS	KS
1	276-05.613	Hoofdas	1	1
2	261-05.132	Vulschijf 15,1x24x0,8	n.	beh.
-	261-05.133	Vulschijf 15,1x24x1,0	n.	beh.
3	DIN 471/560	Borgveer 25x1,2	1	1
4	283-05.900	Koppelingshuis	1	1
5	DIN 625/215	Kogellager 6002 15x32x9	1	1
6	M 1301 z 459	Vulschijf 15,1x21x0,1	n.	beh.
-	M 1301 z 451	Vulschijf 15,1x21x0,2	n.	beh.
-	M 1301 z 452	Vulschijf 15,1x21x0,5	n.	beh.
-	M 1301 z 450	Vulschijf 15,1x21x0,8	n.	beh.
7	DIN 5401/350	Kogel $\phi$ 5	2	2
8	265-05.122	Borgschijf 15,2x25x0,8	1	1
9	265-05.123	Moer M 15x1 (SW 19)	1	1
10	276-05.140	Tandwiel 1e versnelling, 40 t.	1	1
11	277-05.141	Tandwiel 2e versnelling, 35 t.	1	1
12	276-05.142	Tandwiel 3e versnelling, 30 t.	1	1
13	265-05.256	Vulschijf 22,1x32x0,1	n.	beh.
--	265-05.255	Vulschijf 22,1x32x0,2	n.	beh.
--	265-05.257	Vulschijf 22,1x32x0,3	n.	beh.
14	276-05.146	Tandwiel 4e versnelling, 27 t.	1	1
15	276-05.148	Trekspie	1	1
16	276-05.900	Schakelas	1	1
17	278-05.101	Kogel $\phi$ 7	16	16
18	267-05.310	Vulschijf 20,2x28x0,1	n.	beh.
--	278-01.129	Vulschijf 20,2x28x0,2	n.	beh.
--	278-01.130	Vulschijf 20,2x28x0,5	n.	beh.
19	277-05.130	Afstandbus 20,1x25x4,3	1	1
20	276-05.218	Kettingwiel 13 tanden	1	1
21	276-05.198	Vulschijf 15,2x20x0,75	1	1
22	276-05.119	Moer M 15x1	1	1

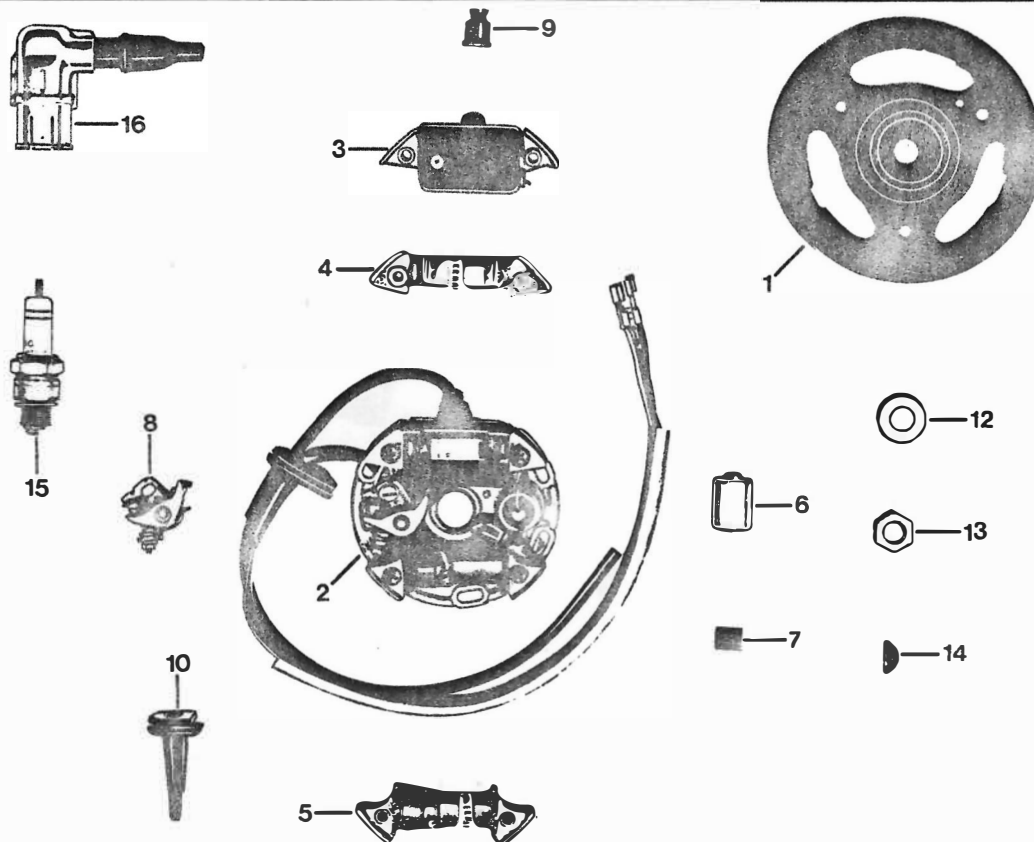

07.278.1

Afb.	Bestelnummer	Omschrijving	CS
1-9	280-07.707	Vliegwiel kpl. 6 V, 19-5 W	1
1	265-07.915	Vliegwiel kaal	1
2	280-07.900	Ankerplaat kpl.	1
3	265-07.909	Ontstekingspoel	1
4	265-07.910	Stoplichtspoel	1
5	265-07.926	Lichtspoel	1
6	266-07.903	Kondensator	1
7	265-07.919	Smeervilt	1
8	265-07.930	Kontaktset	1
9	285-07.144	Rubber tule	1
10	265-07.100	Kabeltule	1
12	DIN 125/600	Vulschijf A 10,5	1
13	DIN 934/600	Moer M 10x1	1
14	DIN 6888/300	Halvemaan-spie 3x3,7	1
15	265-07.101	Bougie W 175	1
16	247-07.703	Bougiekap	1
--	DIN 46340/200	Kabelschoentje 6,3x1	3
--	DIN 84/293	Bout AM 4x16 voor ankerplaat	2
--	DIN 125/250	Vulschijf A 4,3 voor ankerplaat	2

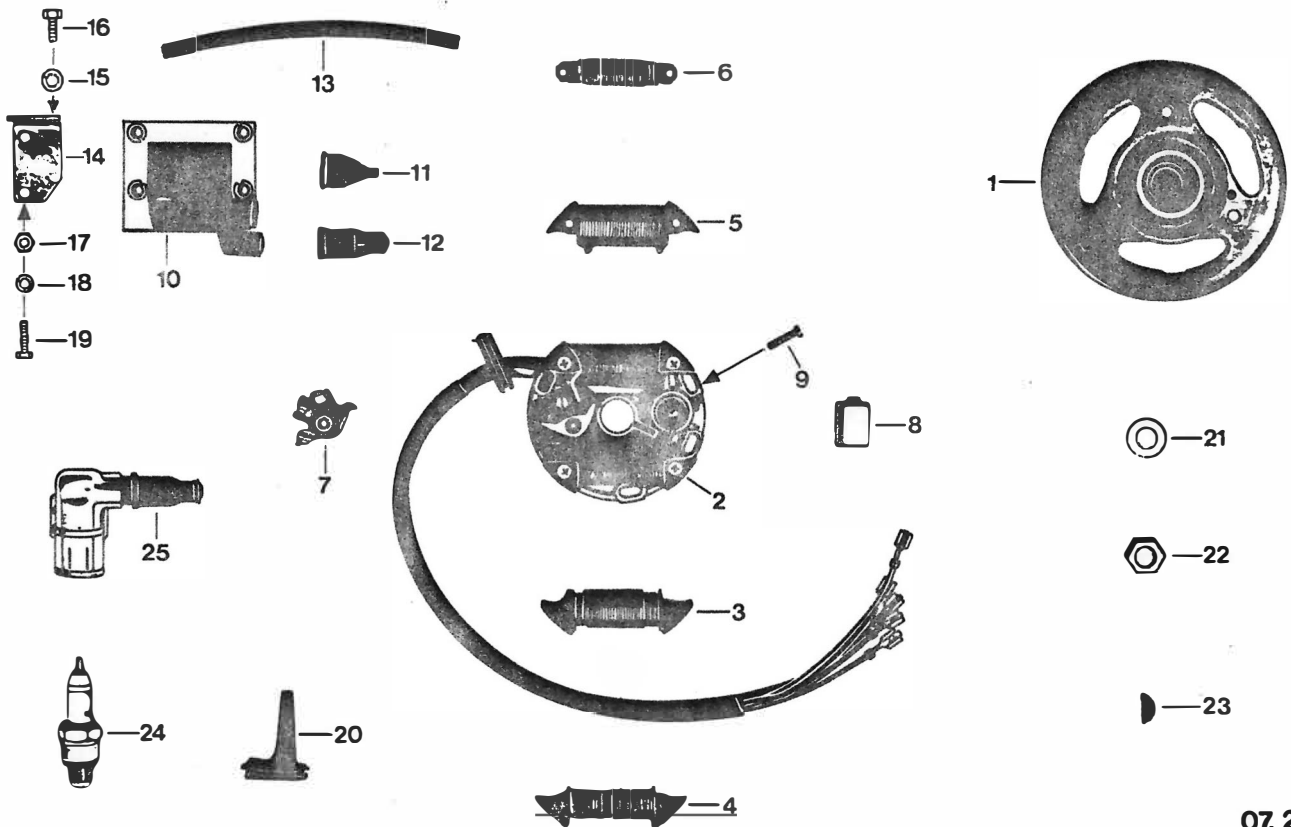

07.278.2

Afb.	Bestelnummer	Omschrijving	GTS	KS
1-8	280-07.709	Vliegwiel kpl. 6 V, 33 W	1	1
1	278-07.900	Vliegwiel kaal	1	1
2	278-07.906	Ankerplaat kpl. met kabel	1	1
3	278-07.905	Commandospoel	1	1
4	278-07.902	Stoplichtspoel 10 W	1	1
5	278-07.904	Lichtspoel 15/5 W	1	1
6	278-07.903	Achterlichtspoel 3 W	1	1
7	265-07.930	Kontaktset	1	1
-	265-07.919	Smeervilt	1	1
8	266-07.903	Kondensator	1	1
9	DIN 84/293	Bout AM 4x16	2	2
-	DIN 125/250	Vulschijf A 4,3	2	2
10	283-07.702	Ontstekingspoel	1	1
11	517-16.108	Kabeltule	2	2
12	282-07.101	Rubber tule	2	2
13	282-07.104	Bougiekabel	1	1
14	517-10.141	Plaat	1	1
15	DIN 127/400	Veerring B 6	1	1
16	DIN 933/320	Bout M 6x12	1	1
17	DIN 934/320	Moer M 5	2	2
18	DIN 127/320	Veerring B 5	2	2
19	DIN 933/270	Bout M 5x22	2	2
20	283-07.100	Kabeltule	1	1
21	DIN 125/600	Vulschijf A 10,5	1	1
22	DIN 934/600	Moer M 10x1	1	1
23	DIN 6888/300	Halvemaan-spie 3x3,7	1	1
24	265-07.101	Bougie W 7 A	1	1
		tot motornr. 9 810 635		
24	280-07.141	Bougie W 8 D	1	1
		vanaf motornr. 9 810 636		
25	284-07.715	Bougiecap	1	1
--	DIN 46340/200	Kabelschoentje 6,1x1	5	5

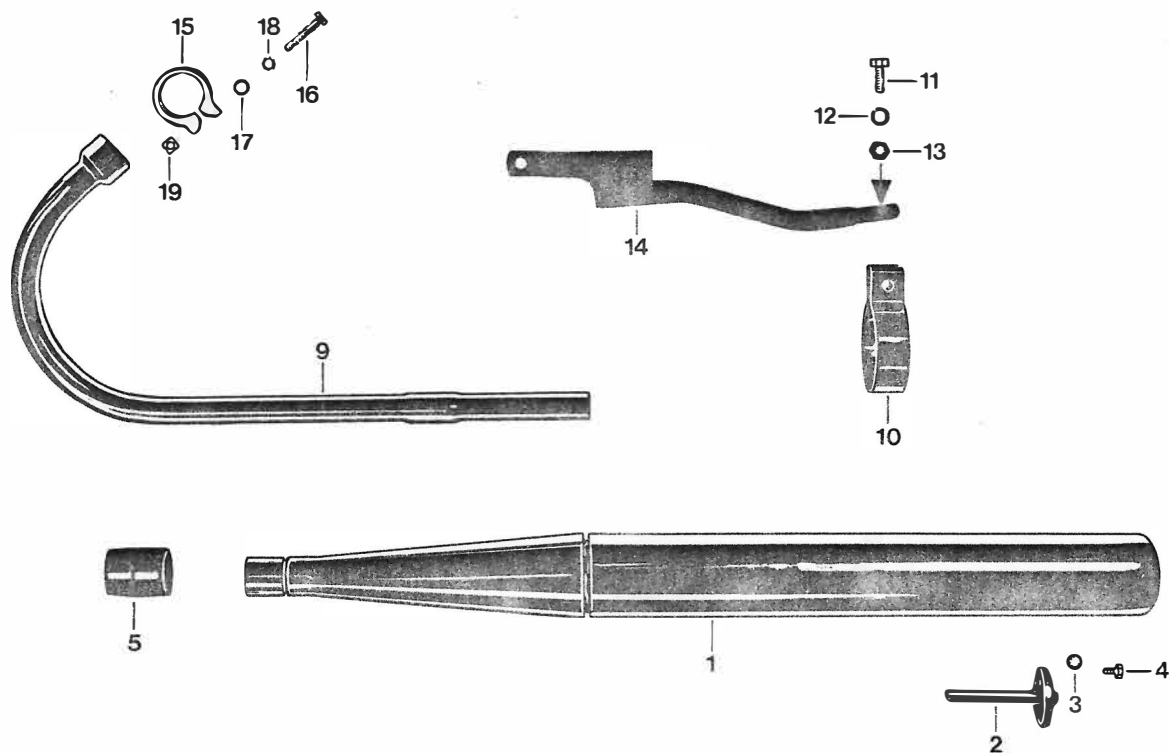

22.529.1

Afb.	Bestelnummer	Omschrijving	CS	GTS	KS
1	529-22.701	Uitlaatdemper	1	1	1
2	529-22.104	Binnendemper	1	1	1
3	DIN 6797/470	Vulschijf J 6,4	1	1	1
4	DIN 933/300	Bout M 6x10	1	1	1
5	446-22.107	Rubber	1	1	1
9	529-22.108	Uitlaatbocht	1	-	-
9	529-22.110	*Uitlaatbocht	-	1	1
9	529-22.608	**Uitlaatbocht	-	1	1
10	517-22.169	Demperklem	1	1	1
11	DIN 933/610	Bout M 8x25	1	1	1
12	DIN 127/560	Veerring B 8	1	1	1
13	DIN 934/500	Moer M 8	1	1	1
14	529-22.600	Ophangbeugel	1	1	1
15	441-22.104	Cylinderklem $\varnothing$ 34,1	1	-	-
15	441-22.104	*Cylinderklem $\varnothing$ 34,1	-	1	1
15	517-22.142	**Cylinderklem $\varnothing$ 38,1	-	1	1
16	DIN 931/300	Bout M 6x35	1	1	1
17	DIN 125/400	Vulschijf A 6,4	1	1	1
18	DIN 6797/400	Vulschijf A 6,4	1	1	1
19	DIN 557/500	Moer M 6	1	1	1

\*tot framnr. 9 315 844

\*\*vanaf framnr. 9 315 845



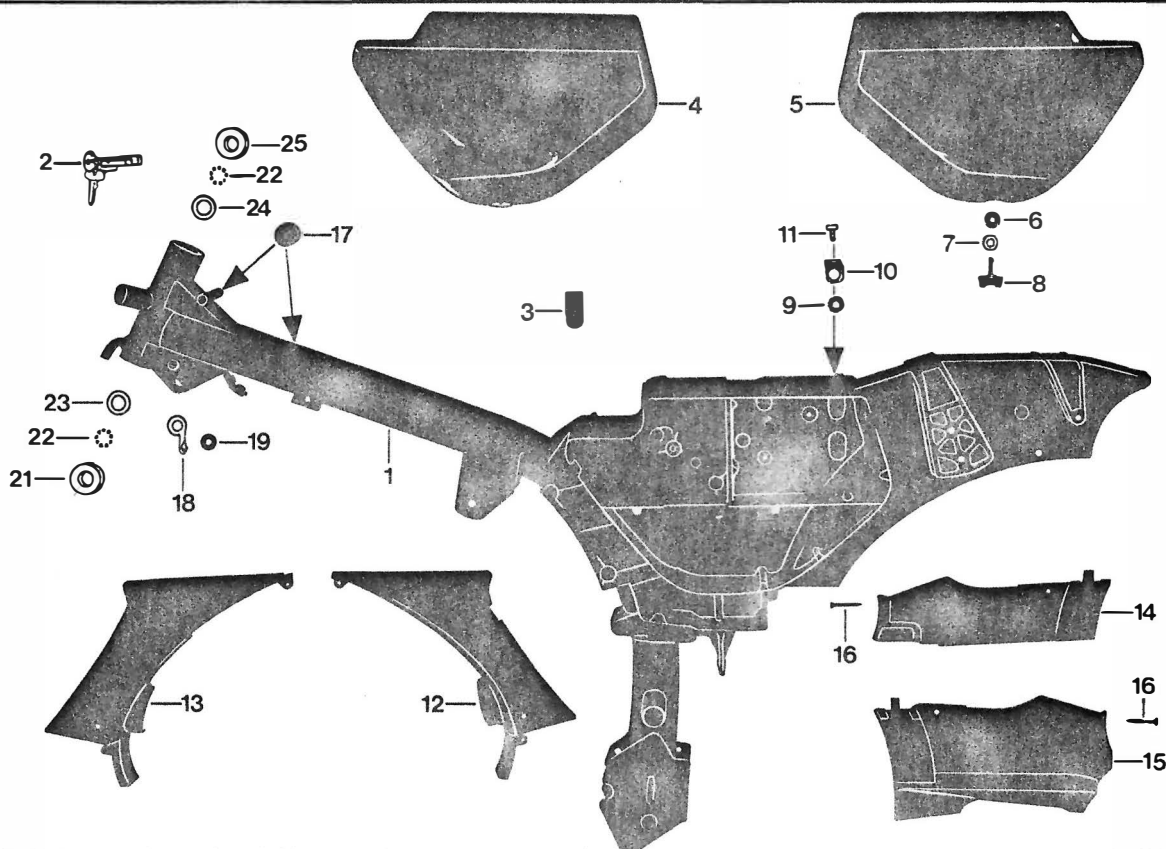

10.529.1

Afb.	Bestelnummer	Omschrijving	CS	GTS	KS
1	529-10.903	Frame met stuurslot	1	1	1
-	529-10.107	Glijlager voor achtervork	2	2	2
2	529-10.906	Stuurslot	1	1	1
3	284-07.132	Kabeltule	1	1	1
4	529-10.115	Luchtfilterdeksel links	1	1	1
5	529-10.116	Gereedschapdeksel rechts	1	1	1
-	529-10.185	Transfer " CS 50 "	2	-	-
-	529-10.182	Transfer " GTS 50 "	-	2	-
-	529-10.186	Transfer " KS 50 "	-	-	2
6	521-10.107	Vulschijf 6,2x12x1	2	2	2
7	400-20.106	Vulschijf 6,4x14x1,5	2	2	2
8	529-10.146	Vleugelmoer	2	2	2
9	529-10.166	Rubber tulle $\varnothing$ 8, lg. 17 mm	4	4	4
10	529-10.164	Borgplaat	4	4	4
11	DIN 933/320	Bout M 6x12	4	4	4
12	529-10.152	Framebeplating voor links	1	1	1
13	529-10.153	Framebeplating voor rechts	1	1	1
--	DIN 84/340	Bout AM 5x12	8	8	8
--	DIN 7971/330	Bout B 3,5x13	1	1	1
14	529-10.155	Framebeplating links	1	1	1
15	529-10.154	Framebeplating rechts	1	-	-
15	529-10.151	Framebeplating rechts	-	1	1
16	DIN 7971/523	Bout B 4,2x32	2	2	2
17	529-10.112	Rubber buffer	4	4	4
18	428-20.115	Kabelhouder	2	1	1
19	428-20.118	Kabeltule $\varnothing$ 6x16	2	1	1
21-25	517-13.700	Balhoofdstel kpl.	1	1	1
21	517-13.104	Balhoofdconus	1	1	1
22	DIN 5401/500	Kogel $\varnothing$ 6	38	38	38
23	517-13.103	Balhoofdcup onder	1	1	1
24	517-13.102	Balhoofdcup boven	1	1	1
25	517-13.101	Stelconus	1	1	1

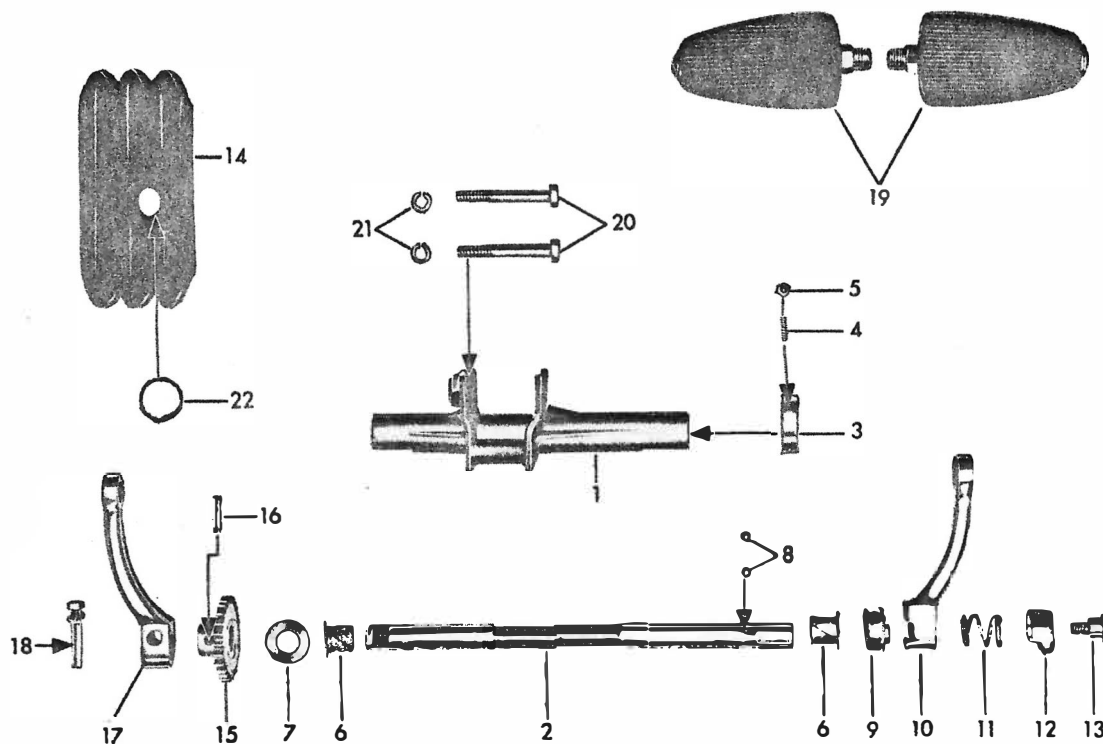

Afb.	Bestelnummer	Omschrijving	CS	GTS	KS
1	517-11.601	Trapaslager	-	1	1
2	517-11.116	Trapas	-	1	1
3	517-11.119	Excenterplaat	-	1	1
4	DIN 914/500	Stelbout M 5x16	-	1	1
5	DIN 934/320	Moer M 5	-	1	1
6	517-11.108	Glijlager	-	2	2
7	265-05.242	Vulschijf 16,2x28x0,5	-	2	2
8	DIN 5401/350	Kogel $\varnothing$ 5	-	2	2
9	266-05.191	Meenemer	1	1	1
10	517-11.100	Krank R.	1	1	1
11	517-11.101	Drukveer	1	1	1
12	517-11.102	Kapje	1	1	1
13	517-11.103	Bout	1	1	1
14	517-14.154	Kettingkast-manchet	-	1	1
15	517-11.600	Tandwiel 25 tanden	-	1	1
16	DIN 1473/600	Borgpen 6x24	-	1	1
17	405-11.242	Krank L.	1	1	1
18	529-11.103	Krankspie compleet	1	1	1
19	442-11.901	Pedalen ( set )	1	1	1
20	DIN 931/600	Bout M 8x60	-	2	2
21	DIN 127/560	Veerring B 8	-	2	2
22	517-11.120	Bus	-	1	1

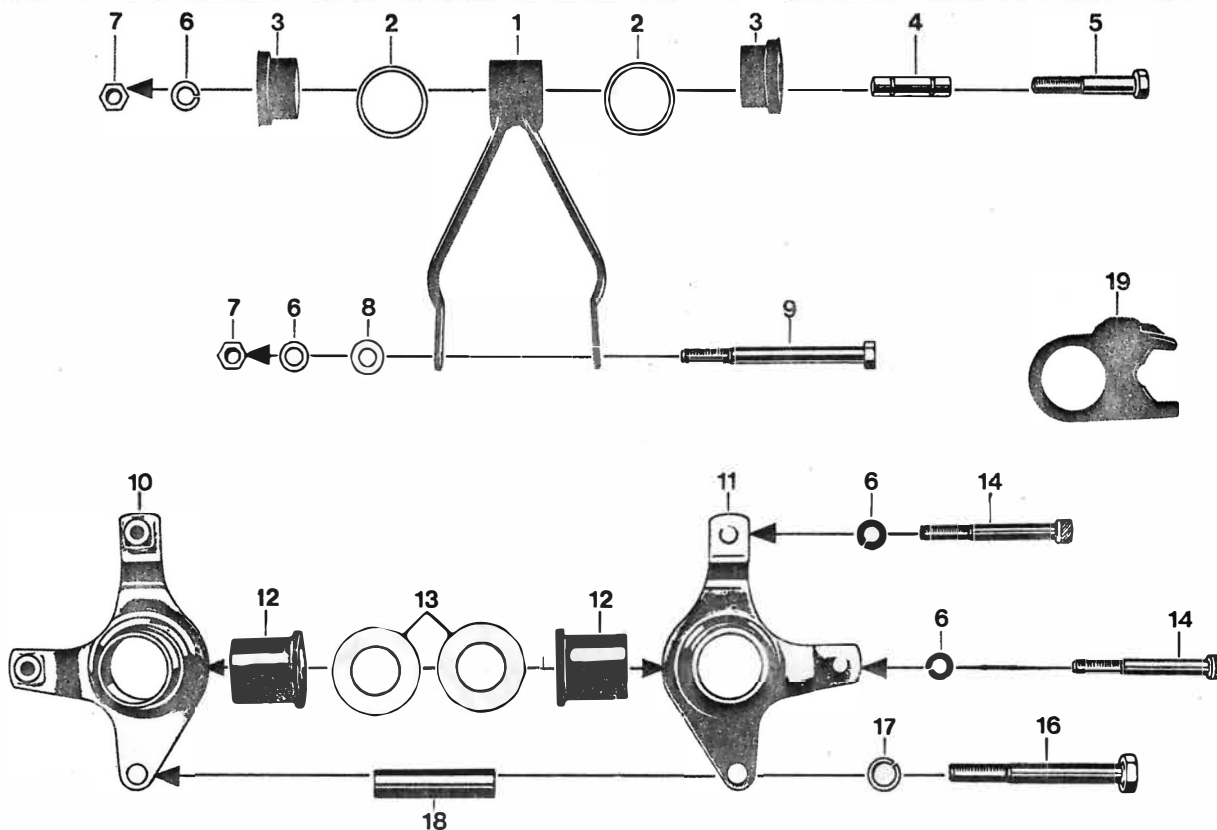

18.529.1

Afb.	Bestelnummer	Omschrijving	CS	GTS	KS
1	529-18.607	Ophangsteun	1	-	-
-	529-18.600	Ophangsteun	-	1	1
2	517-18.110	Vulschijf 30,2x37x1,5	2	2	2
3	517-18.109	Ophangrubber	2	2	2
4	428-18.108	Afstandsbus	1	1	1
5	DIN 931/590	Bout M 8x55	1	1	1
6	DIN 127/560	Veerring B 8	4	4	4
7	DIN 934/500	Moer M 8	2	2	2
8	405-18.109	Vulschijf 8,4x16x3	1	1	1
9	DIN 931/670	Bout M 8x95	1	1	1
10	529-18.605	Ophangsteun L.	1	1	1
11	529-18.606	Ophangsteun R.	1	1	1
12	529-18.107	Ophangrubber	2	2	2
13	529-18.104	Vulschijf 26,2x45x5	2	2	2
14	DIN 931/620	Bout M 8x65	2	2	2
16	DIN 931/790	Bout M 10x90	1	1	1
17	DIN 127/640	Veerring B 10	1	1	1
18	529-18.108	Afstandsbus	1	1	1
19	529-18.109	Geleider	1	1	1

Telescoopvoorvork

CS GTS

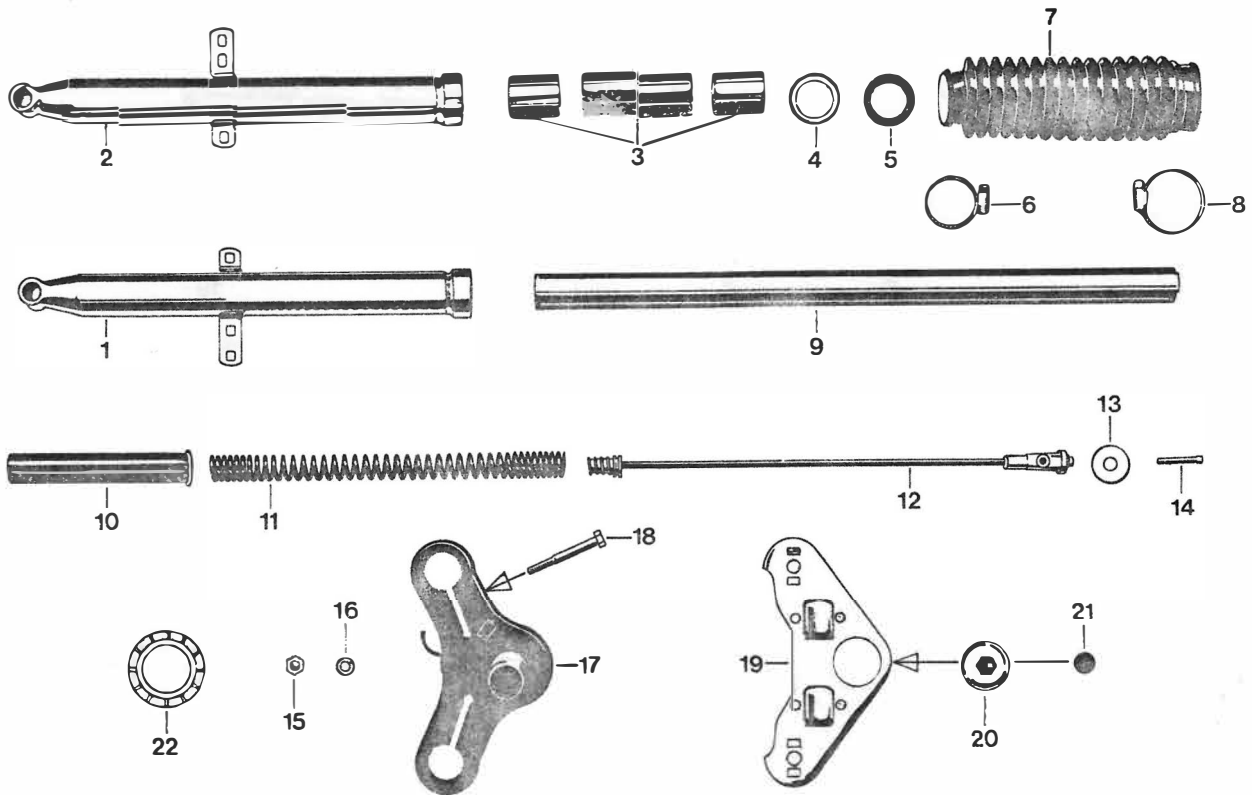

12.529.1

Afb.	Bestelnummer	Omschrijving	CS	GTS
-	529-12.901	Telescoopvoorvork kpl.	1	1
1	529-12.637	Onderpoot links	1	1
2	529-12.638	Onderpoot rechts	1	1
3	517-12.906	Glijbusset voor twee vorkpoten	1	1
4	517-12.140	Ring	2	2
5	520-12.142	Oliekeerring 30x40 G2/52	2	2
6	DIN 3017/390	Klemband LA 25-40	2	2
7	517-12.198	Harmonicarubber	2	2
8	DIN 3017/410	Klemband LA 32-50	2	2
9	529-12.623	Binnenpoot	2	2
10	517-12.131	Veergeleiderhuls	2	2
11	515-12.254	Voorvorkveer	2	2
12	529-12.612	Veerhouder	2	2
13	517-12.162	Vulschijf 8,4x32x3	2	2
14	529-12.101	Bout M 8x1x35	2	2
15	DIN 934/500	Moer M 8	2	2
16	DIN 127/560	Veerring B 8	2	2
17	530-12.612	Kroonstuk	1	1
18	DIN 931/600	Bout M 8x60	2	2
19	529-12.600	Vorkverbinding	1	1
20	529-13.105	Balhoofdmoer	1	1
21	529-13.106	Afsluitdop	1	1
22	515-12.209	Afstandsbus	2	2

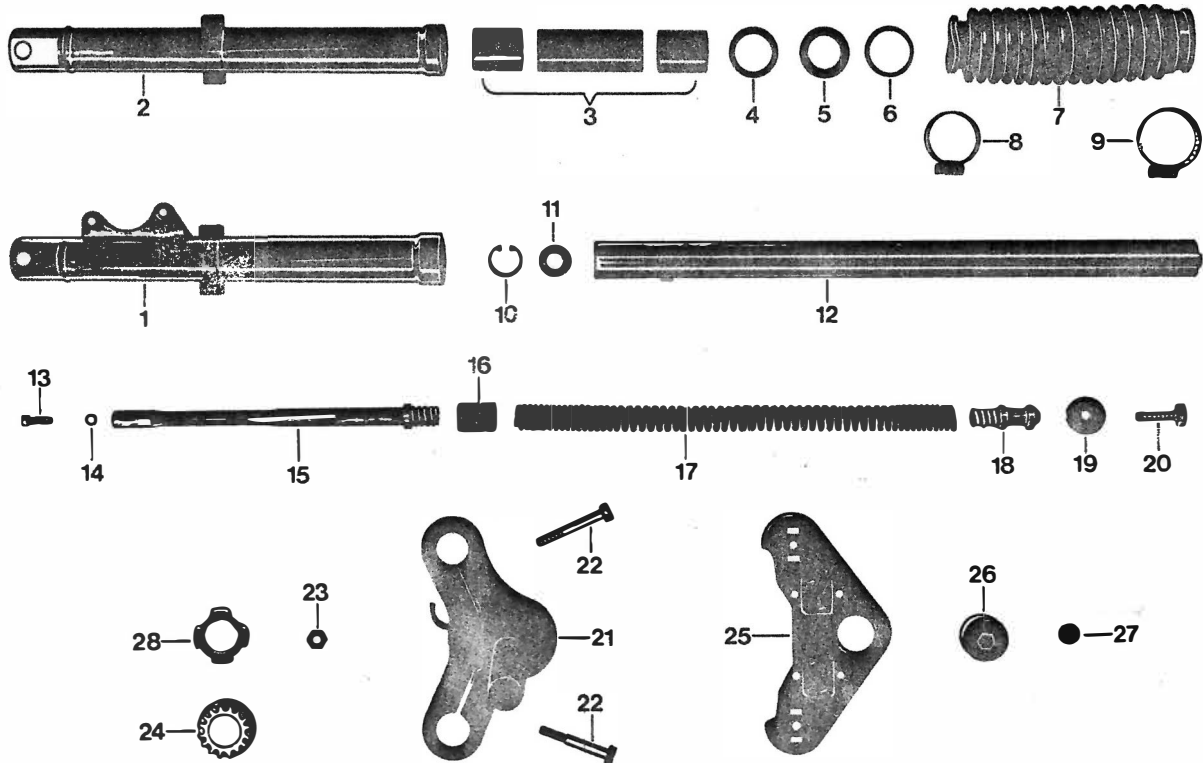

12.530.3

Afb.	Bestelnummer	Omschrijving	KS
-	530-12.903	Telescoopvoorvork kpl.	1
1	530-12.617	Onderpoot L.	1
2	530-12.618	Onderpoot R.	1
3	517-12.906	Glijbusset voor twee vorkpoten	1
4	517-12.140	Ring	2
5	520-12.142	Oliekeerring 30x40 G2/52	2
6	530-12.110	Afdichtring 34,5x40x1	2
7	517-12.198	Harmonicarubber	2
8	DIN 3017/390	Klemband LA 25-40	2
9	DIN 3017/410	Klemband LA 32-50	2
10	DIN 472/260	Borgveer 26x1,2	2
11	530-12.136	Vulschijf 14,4x26x3	2
12	530-12.622	Binnenpoot	2
13	DIN 6912/510	Bout M 6x25	2
14	520-12.271	O-Ring	2
15	530-12.101	Veerhouder	2
16	530-12.102	Veergeleiderhuls	2
17	530-12.139	Voorvorkveer	2
18	529-12.116	Veerhouder boven	2
19	517-12.162	Vulschijf 8,4x32x3	2
20	529-12.101	Bout M 8x1x35	2
21	530-12.612	Kroonstuk	1
22	DIN 931/600	Bout M 8x60	2
23	DIN 934/500	Moer M 8	2
24	515-12.209	Afstandsbus	2
25	529-12.600	Vorkverbinding	1
26	529-13.105	Balhoofdmoer	1
27	529-13.106	Afsluitdop	1
28	512-12.135	Rubberring	2

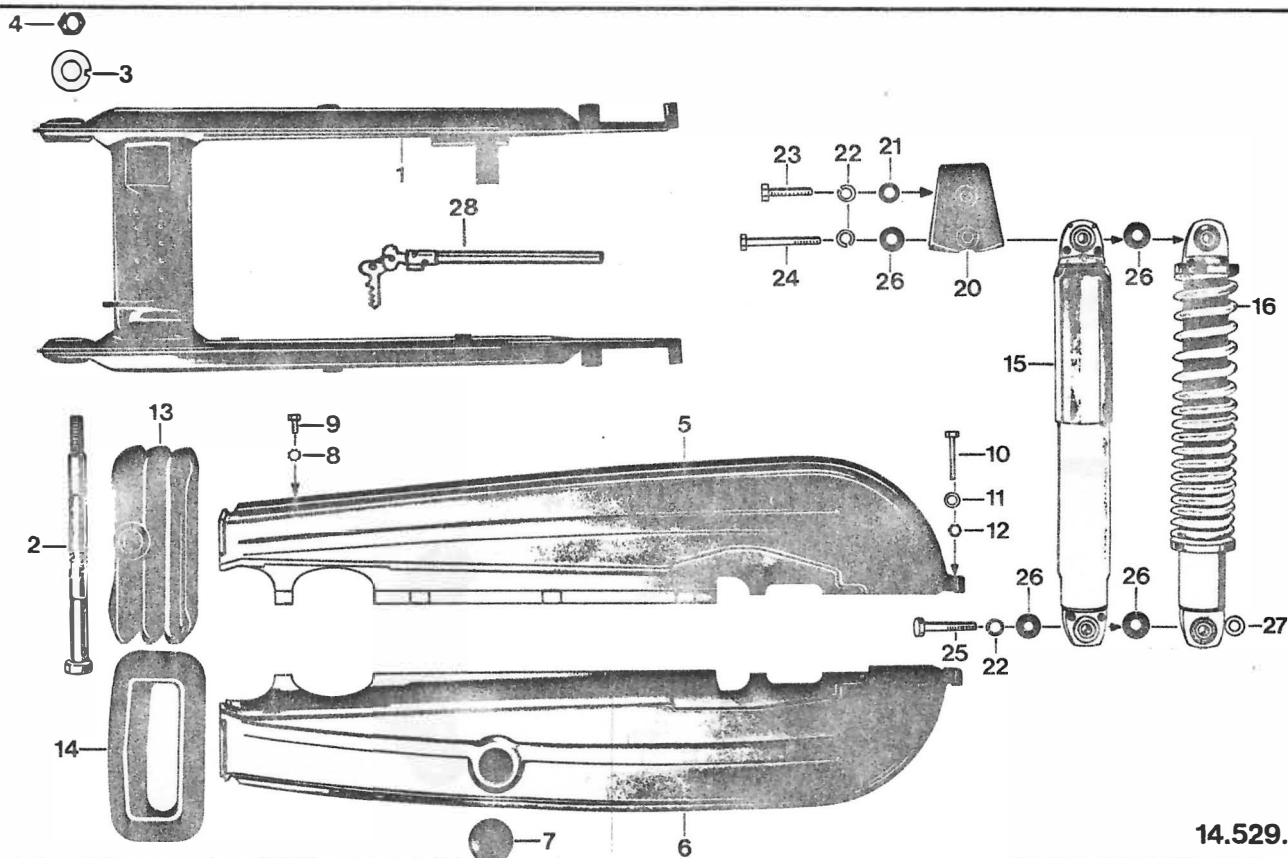

14.529.3

Afb.	Bestelnummer	Omschrijving	CS	GTS	KS
1	529-14.620	Achtersvork kpl.	1	1	1
2	529-14.110	Swingarmas	1	1	1
3	278-05.112	Borgplaatje $\varnothing$ 13	1	1	1
4	DIN 936/600	Moer M 12x1,5	1	1	1
5	529-14.618 <u>kleur</u>	Kettingkastdeel boven	1	1	1
6	529-14.602 <u>kleur</u>	Kettingkastdeel onder	1	1	1
7	432-14.117	Inspektierrubber	1	1	1
8	DIN 6797/400	Vulschijf A 6,4	2	2	2
9	DIN 912/265	Bout M 6x10	2	2	2
10	DIN 931/300	Bout M 6x35	1	1	1
11	DIN 137/360	Veerring B 6	1	1	1
12	DIN 934/410	Moer M 6	1	1	1
13	517-14.154	Kettingkast-manchet	-	1	1
14	517-14.119	Kettingkast-manchet	1	-	-
15	529-14.704	Schokbreker kpl.			
		tot framennr. 9 314 578	2	-	-
16	529-14.703	Schokbreker kpl.			
		voor GTS tot framennr. 9 314 578	-	2	2
16	529-14.706	Schokbreker kpl.			
		vanaf framennr. 9 314 579	2	2	-
--	529-14.131	Sleutel ( v. 529-14.703 )	-	2	2
20	529-14.100	Schokbrekerplaat	2	2	2
21	DIN 125/550	Vulschijf A 8,4	2	2	2
22	DIN 127/560	Veerring B 8	6	6	6
23	DIN 933/630	Bout M 8x35	2	2	2
24	DIN 931/610	Bout M 8x60	2	2	2
25	DIN 931/550	Bout M 8x42/22	2	2	2
26	422-14.183	Vulschijf 8x20x2	8	8	8
27	405-18.109	Vulschijf 8,4x16x3	2	2	2
28	529-10.905	Pen slot $\varnothing$ 15 mm	1	1	1

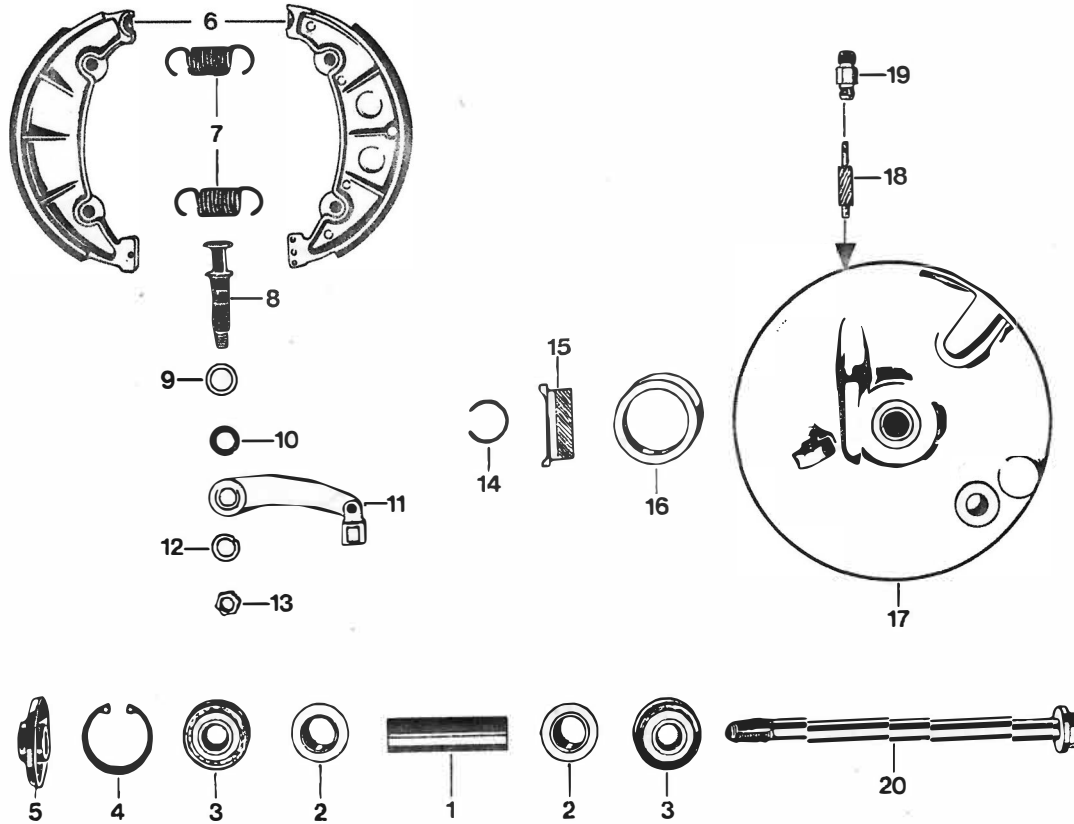

15.530.3

Afb.	Bestelnummer	Omschrijving	CS	GTS
-	530-15.606	Alu voorwiel met lagers en remtrommel	1	1
1	530-15.100	Afstandbus 67,2 mm	1	1
2	530-15.101	Vulschijf 18,4x30	2	2
3	DIN 625/632	Kogellager 6301 Z 12x37x12	2	2
4	DIN 472/480	Borgveer 37x 1,5	1	1
5	530-15.603	Tussenbus	1	1
6	517-15.921	Remsegmenten ( set)	1	1
7	517-15.133	Remsegmentveer	2	2
8	561-15.620	Remsleutel	1	1
9	267-05.597	Vulschijf 0,2 mm	1	1
10	405-15.388	O-Ring	1	1
11	517-15.607	Remhevel	1	1
12	DIN 127 /560	Veerring B 8	1	1
13	DIN 936 /410	Moer M 8x1	1	1
14	DIN 9045 /600	Borgring A 22	1	1
15	517-15.151	Tellertandwiel	1	1
16	510-15.164	Viltring	1	1
17	517-15.605	Remankerplaat kaal	1	1
18	515-15.106	Tellerasje 12T.	1	1
19	515-15.100	Draadstukje voor telleraandrijving	1	1
20	512-15.104	Steekas	1	1
--	530-15.110	Buitenband 2 3/4 - 17	1	1
--	433-15.216	Binnenband 2 3/4 - 17	1	1

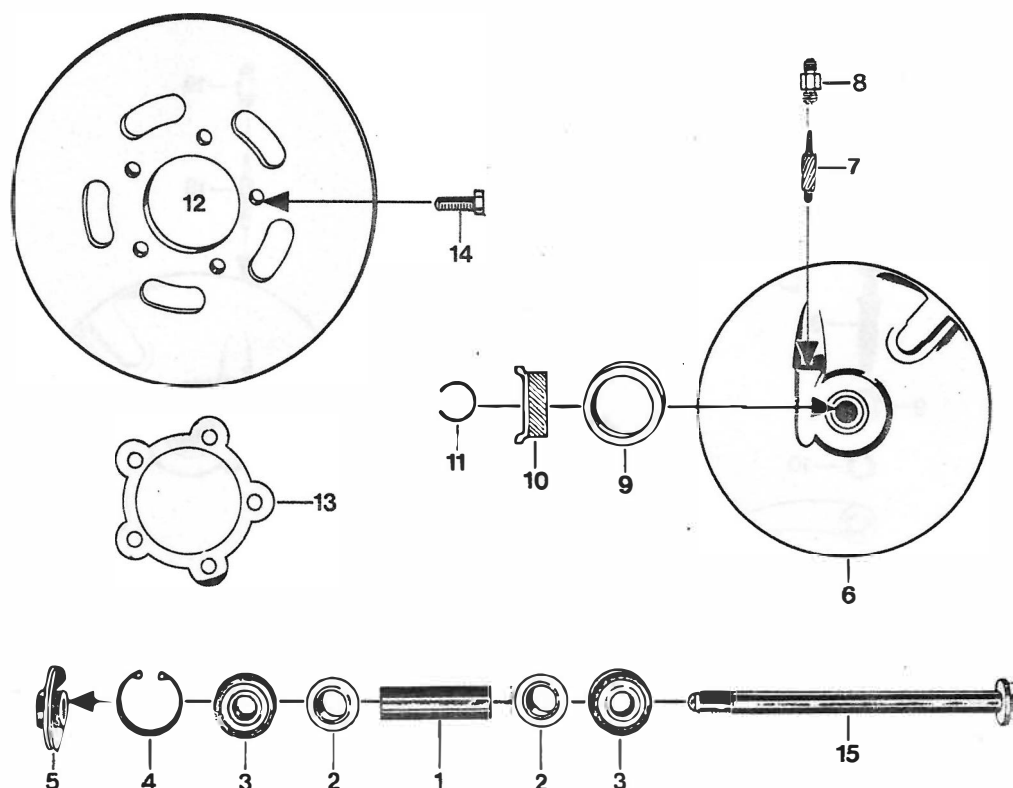

15.530.4

Afb.	Bestelnummer	Omschrijving	KS
-	530-15.608	Alu voorwiel met lagers	1
1	530-15.100	Afstandbus 67,2 mm	1
2	530-15.101	Vulschijf 18,4x30	2
3	DIN 625/632	Kogellager 6301 Z 12x37x12	2
4	DIN 472/480	Borgveer 37x1,5	1
5	530-15.603	Tussenbus	1
6	530-15.605	Remankerplaat kaal	1
7	515-15.106	Tellerasje 12 tanden	1
8	515-15.100	Draadstukje voor telleraandrijving	1
9	510-15.164	Viltring	1
10	517-15.151	Tellertandwiel	1
11	DIN 9045/600	Borgring A 22	1
12	530-15.142	Remschijf $\varnothing$ 220 mm	1
13	530-15.108	Zekeringsplaat	1
14	DIN 933/590	Bout M 8x22	5
15	512-15.104	Steekas	1
--	530-15.110	Buitenband 2 3/4-17	1
--	433-15.216	Binnenband 2 3/4-17	1



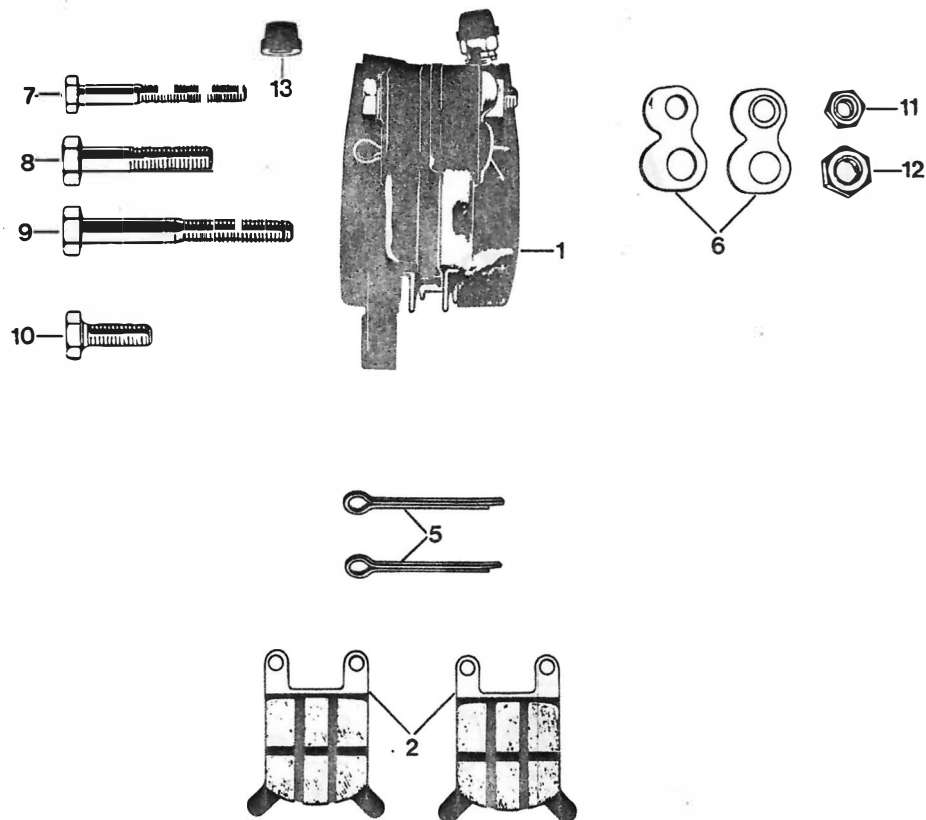

15.530.6

Afb.	Bestelnummer	Omschrijving	KS
1	530-15.707	Remklauw compleet	1
2	530-15.112	Remblokken per stel	1
5	530-15.900	Splitpen	2
6	530-15.904	Borgplaat	2
7	DIN 931/310	Bout M 6x40	2
8	DIN 931/540	Bout M 8x40	1
9	DIN 931/590	Bout M 8x55	1
10	DIN 933/610	Bout M 8x25	1
11	DIN 934/410	Moer M 6	2
12	DIN 934/500	Moer M 8	2
13	530-15.903	Afdekplaat	1

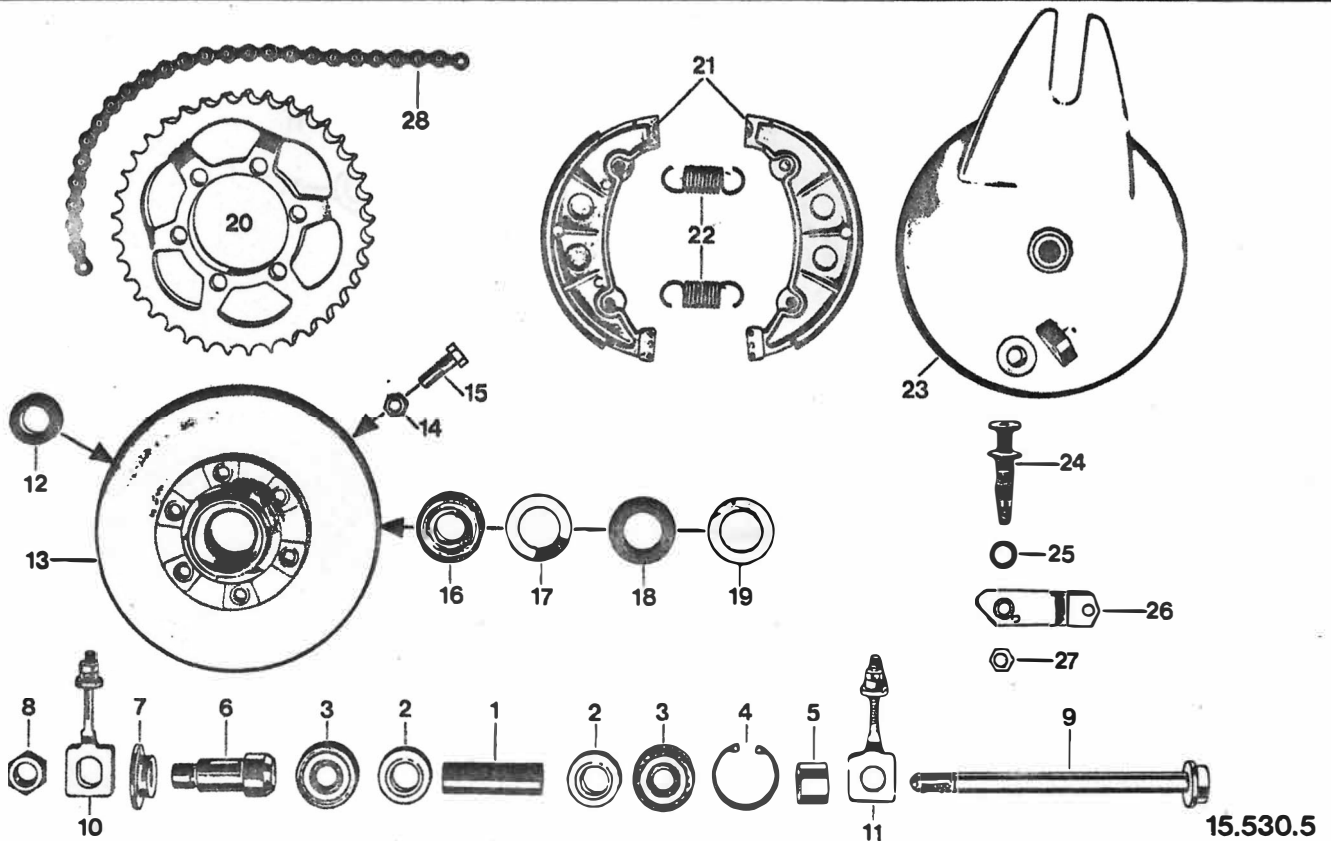

15.530.5

Afb.	Bestelnummer	Omschrijving	CS	GTS	KS
-	530-15.607	Alu-achterwiel met lagers	1	1	1
1	530-15.104	Afstandbus 59,5 mm	1	1	1
2	530-15.101	Vulschijf 18,4x30	2	2	2
3	DIN 625/632	Kogellager 6301 Z 12x37x12	2	2	2
4	DIN 472/480	Borgveer 37x1,5	1	1	1
5	433-15.136	Afstandsring	1	1	1
6	529-15.100	Draadbus	1	1	1
7	433-15.126	Afstandsring	1	1	1
8	433-15.131	Moer	1	1	1
9	433-15.147	Steekas	1	1	1
10	529-15.711	Kettingspanner L.	1	1	1
11	529-15.712	Kettingspanner R.	1	1	1
12	517-15.112	Tandwielrubber	6	6	6
13	517-15.915	Naafflens afb. 13-15	1	1	1
14	561-17.111	Moer	6	6	6
15	DIN 931/492	Bout M 8x25/14	6	6	6
--	DIN 127/560	Veerring B 8	6	6	6
16	DIN 625/485	Kogellager 6203 Z 17x40x12	1	1	1
17	433-15.117	Afdekplaat	1	1	1
18	433-15.119	Viltring	1	1	1
19	433-15.121	Kap	1	1	1
20	423-15.405	Kettingwiel 41 tanden	1	-	-

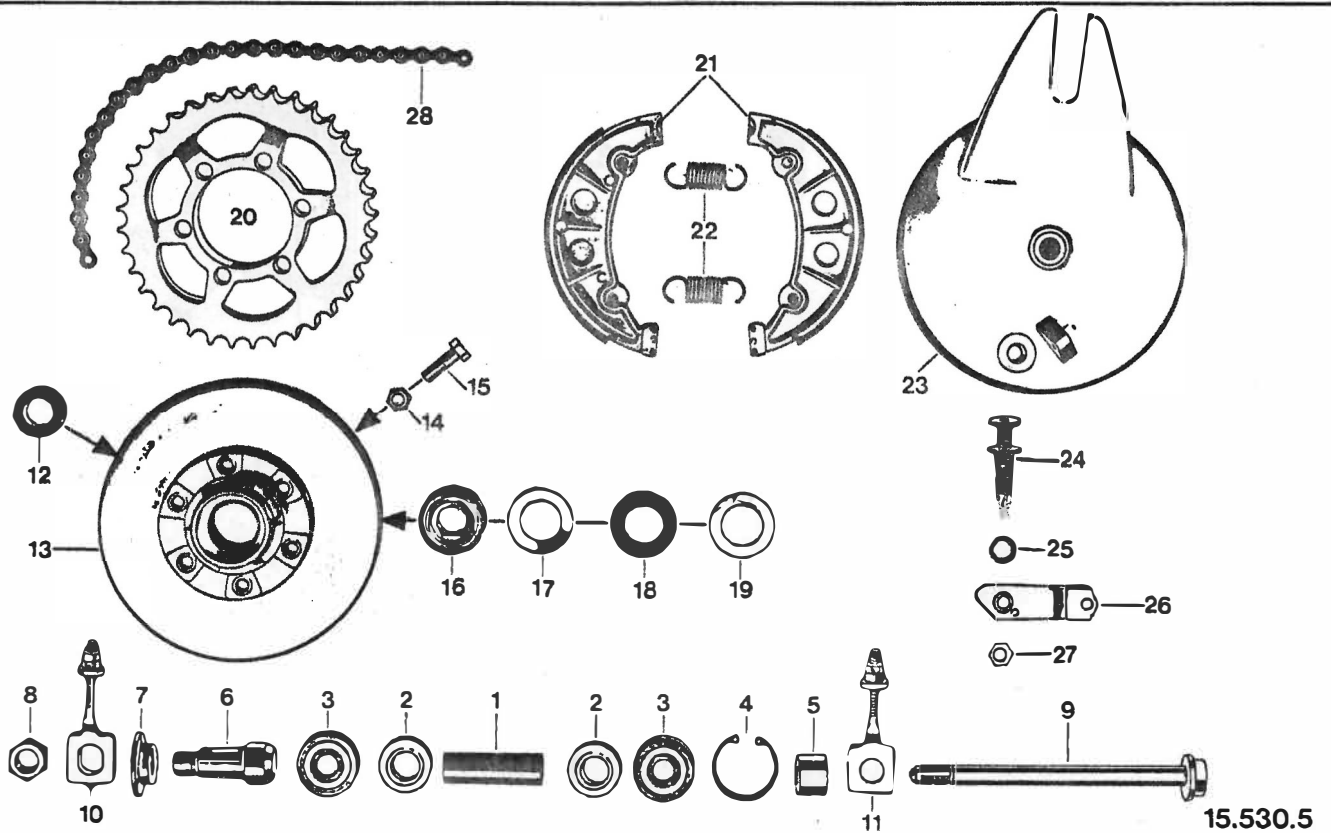

Afb.	Bestelnummer	Omschrijving	CS	GTS	KS
20	423-15.406	Kettingwiel 43 tanden	-	1	1
21	517-15.921	Remsegmenten ( set )	1	1	1
22	517-15.133	Remsegmentveer	2	2	2
23	517-15.611	Remankerplaat	1	1	1
24	517-15.606	Remsleutel	1	1	1
25	405-15.388	O-Ring	1	1	1
--	267-05.597	Vulschijf 0,2 mm	1	1	1
26	530-15.611	Remhevel	1	1	1
27	DIN 936/410	Moer M 8x1	1	1	1
28	429-18.640	Ketting met slot 1/2"x3/16" 114 schakels	1	-	-
28	517-18.609	Ketting met slot 1/2"x3/16" 122 schakels	-	1	1
--	432-18.900	Slot voor ketting 1/2"x3/16"	1	1	1
--	530-15.111	Buitenband 2 3/4 - 17	1	1	1
--	433-15.216	Binnenband 2 3/4 - 17	1	1	1

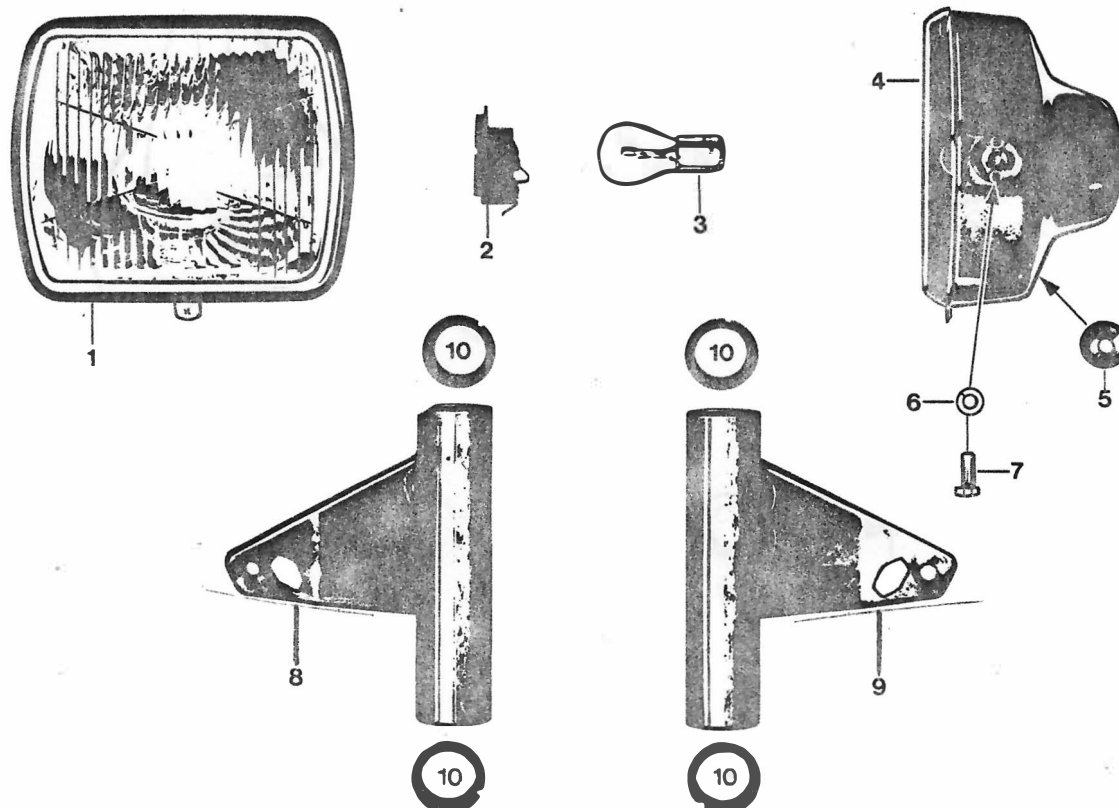

16.530.6

Afb.	Bestelnummer	Omschrijving	CS	GTS	KS
1	529-16.776	Inbouwset kpl. 6V, C 15/15 W zonder lampje	1	1	1
2	529-16.162	Fitting	1	1	1
3	DIN 72601/325	Lampje 6 V, C 15/15 W	1	1	1
4	529-16.655 <u>kleur</u>	Koplamphuis	1	1	1
5	517-16.239	Kabeltule	1	1	1
-	DIN 125/550	Vulschijf A 8,4	2	-	-
6	DIN 127/560	Veerring B 8	2	2	2
7	DIN 933/580	Bout M 8x20	2	2	2
8	529-16.651 <u>kleur</u>	Koplamphouder links voor CS tot framenr. 9 347 686	1	1	1
-	529-161625 <u>kleur</u>	Koplamphouder links vanaf framenr. 9 347 687	1	-	-
9	529-16.652 <u>kleur</u>	Koplamphouder rechts voor CS tot framenr. 9 347 686	1	1	1
-	529-161626 <u>kleur</u>	Koplamphouder rechts vanaf framenr. 9 347 687	1	-	-
10	517-12.182	Bus	4	4	4

Achterlicht - dimschakelaar - kabelboom

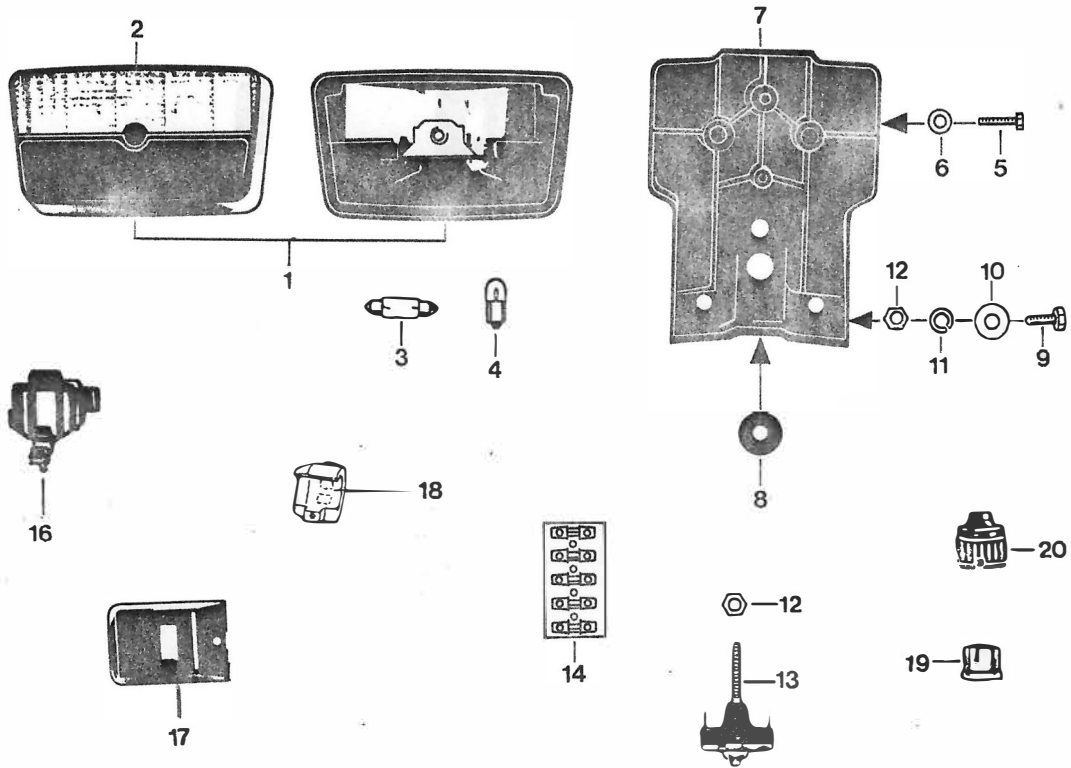

16.529.3

Afb.	Bestelnummer	Omschrijving	CS	GTS	KS
1	529-16.711	Achterlicht ( zonder lampje )	1	1	1
2	529-16.903	Achterlichtglas	1	1	1
3	DIN 72601/625	Lampje L6V, 5W voor stoplicht	1	1	1
4	DIN 72601/475	Lampje HL6V, 4W voor achterlicht	1	-	-
4	517-16.379	Lampje H6V, 3W voor achterlicht	-	1	1
5	DIN 84/356	Bout AM 5x16	1	1	1
6	DIN 137/320	Veerring A 5	1	1	1
7	529-16.611	Achterlichtsteun	1	1	1
8	520-12.282	Kabeltule	1	1	1
9	DIN 933/346	Bout M 6x16	3	3	3
10	DIN 9021/600	Vulschijf A 6,4	6	6	6
11	DIN 127/400	Veerring B 6	3	3	3
12	DIN 934/410	Moer M 6	5	5	5
13	517-16.113	Stoplichtschakelaar	1	1	1
14	446-16.125	Kabelverbinder 6-delig	3	4	4
16	518-16.742	Dimschakelaar kaal	1	-	-
17	521-16.777	Dimschakelaar kaal tot framnr. 9 332 082	-	1	-
18	529-161712	Dimschakelaar kaal vanaf framnr. 9 332 083	-	1	-
19	521-16.335	Stekkerdoosje	-	-	2
20	521-16.336	Stofkapje	-	-	2
--	529-16.678	Kabelboom	-	-	1

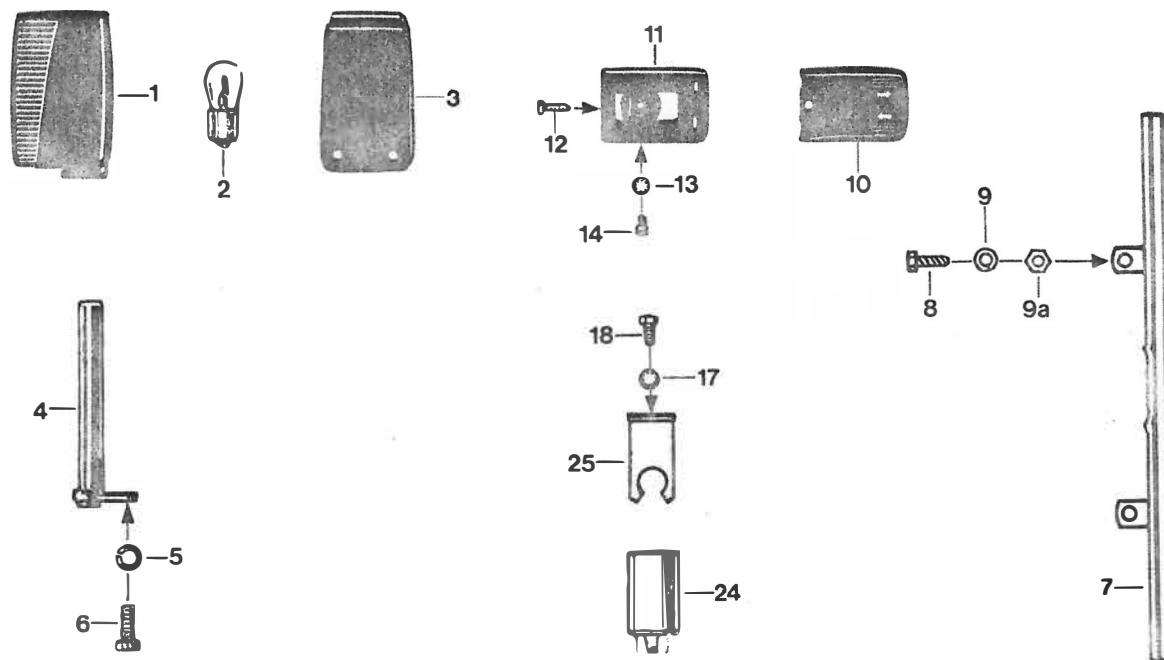

16.529.7

Afb.	Bestelnummer	Omschrijving	GTS	KS
1	530-16.769	Knipperlicht zonder lampje	-	4
2	DIN 72601/400	Lampje G6V, 5W	-	4
3	530-16.124	Knipperlichtglas	-	4
4	529-16.665	Houder knipperlicht voor	-	2
5	DIN 127/560	Veerring B 8	-	2
6	DIN 933/580	Bout M 8x20	-	2
7	529-161621	Houder knipperlicht achter	-	1
8	DIN 933/350	Bout M 6x18	-	2
9	DIN 137/360	Veerring B 6	-	2
9a	DIN 934/410	Moer M 6	-	2
10	521-16.781	*R. A. W. schakelaar kaal	1	-
11	529-16.113	*Schakelaarhouder	1	-
12	DIN 7971/400	*Bout B 3,9x16	1	-
13	DIN 6797/320	*Vulschijf J 5,3	1	-
14	DIN 7971/525	*Bout B 4,8x9,5	1	-
17	DIN 6797/470	Vulschijf J 6,4	1	1
18	DIN 933/320	Bout M 6x12	1	1
24	529-16.911	Automaat met houder	1	1
25	529-16.151	Houder voor automaat	1	1

\*voor GTS tot framennr. 9 332 082

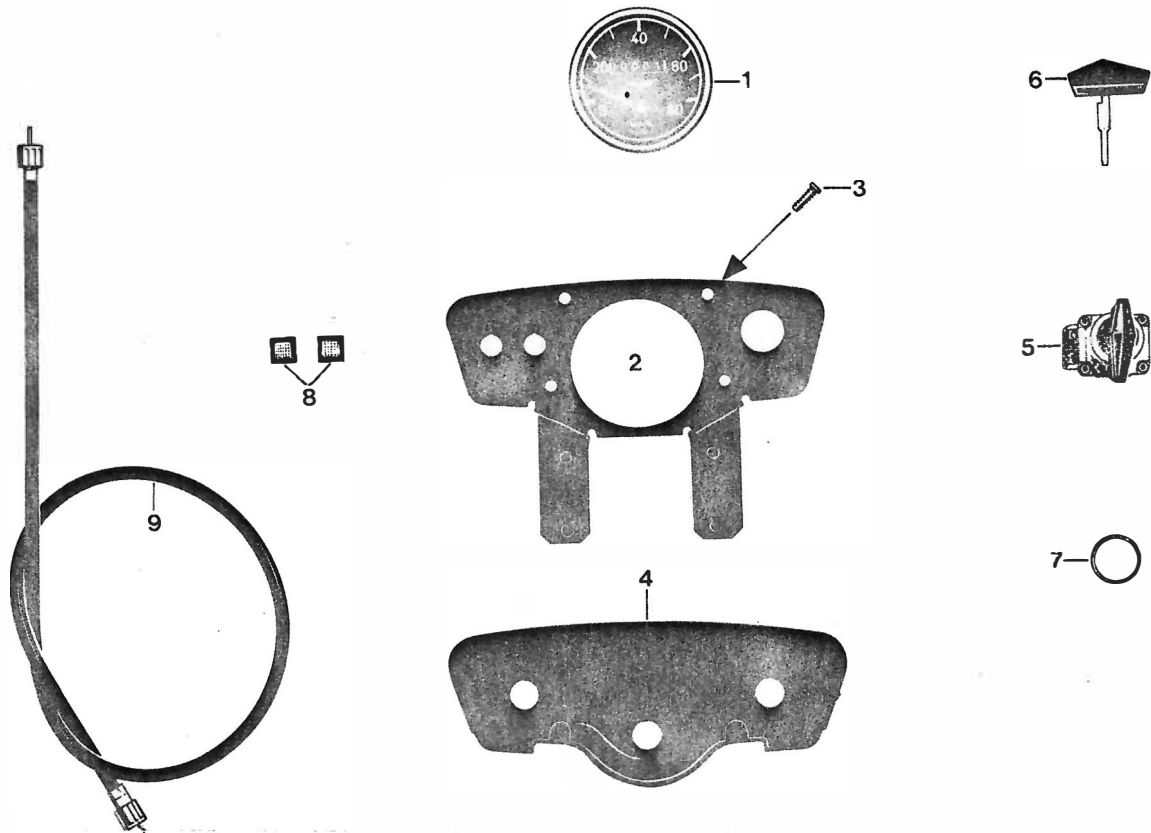

16.529.4

Afb.	Bestelnummer	Omschrijving	CS
1	529-16.907	Tellerklok $\varnothing$ 60, 80 km/h	1
-	DIN 72601/520	Lampje J6V, 0,6W voor tellerklok	1
-	529-16.124	Beugel voor tellerklok	1
-	529-16.125	Moer voor tellerklok	1
2	529-16.600	Drager	1
3	DIN 7981/425	Bout BZ 4,8x13	4
4	517-16.372	Tellerhuis	1
5	519-16.780	Kontaktschakelaar kpl.	1
6	515-16.939	Kontaktsleutel	1
7	517-16.376	Tussenring	1
8	519-16.612	Controle glas groen	1
8	517-16.667	Controlelampje blauw	1
9	519-16.668	Tellerkabel	1

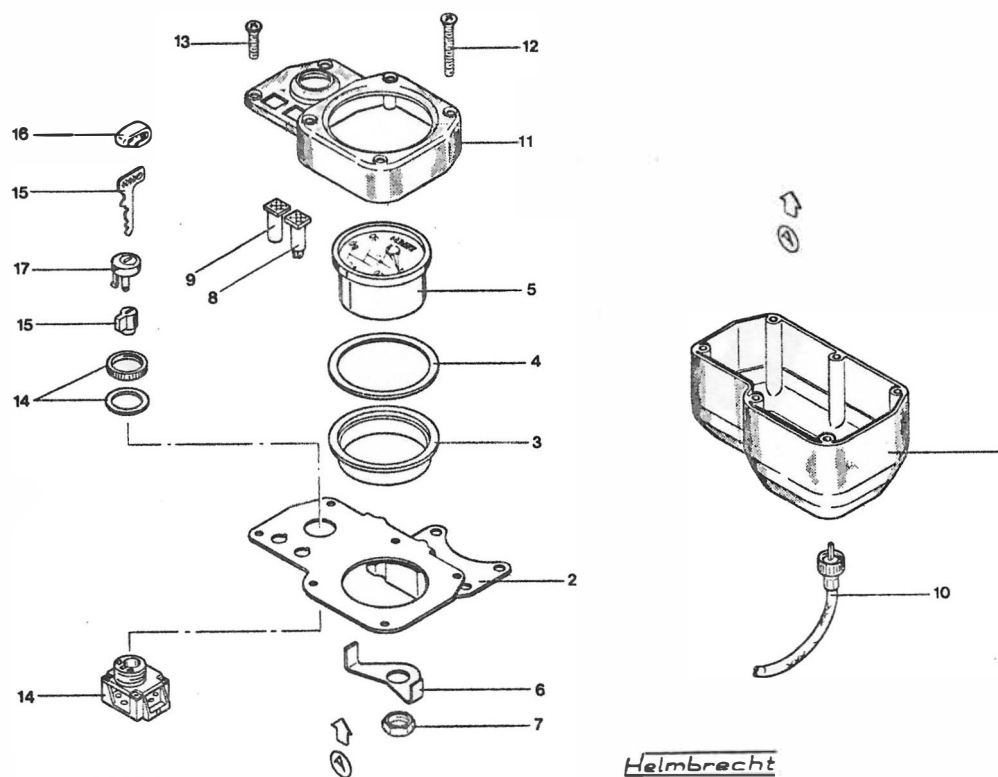

16.448.5

Afb.	Bestelnummer	Omschrijving	CS
1	448-16.113	Cockpithuis	1
2	529-161624	Drager	1
3	448-16.124	Afstandsring	1
4	448-16.125	Rubber ring	1
5-7	529-16.919	Tellerklok $\varnothing$ 60, 80 km/h	1
-	DIN 72601/520	Lampje J6V, 0,6 W	1
6	448-16.123	Beugel	1
7	529-16.125	Moer	1
8	517-16.667	Controle lampje blauw	1
9	519-16.612	Controle glas groen	1
10	519-16.668	Tellerkabel	1
11	448-16.115	Deksel	1
12	DIN 7983/500	Bout BZ 4,2x38	4
13	DIN 7983/300	Bout BZ 4,2x16	2
14-17	530-16.908	Kontaktschakelaar compl.	1
16	529-16.152	Kapje voor kontaktsleutel	1



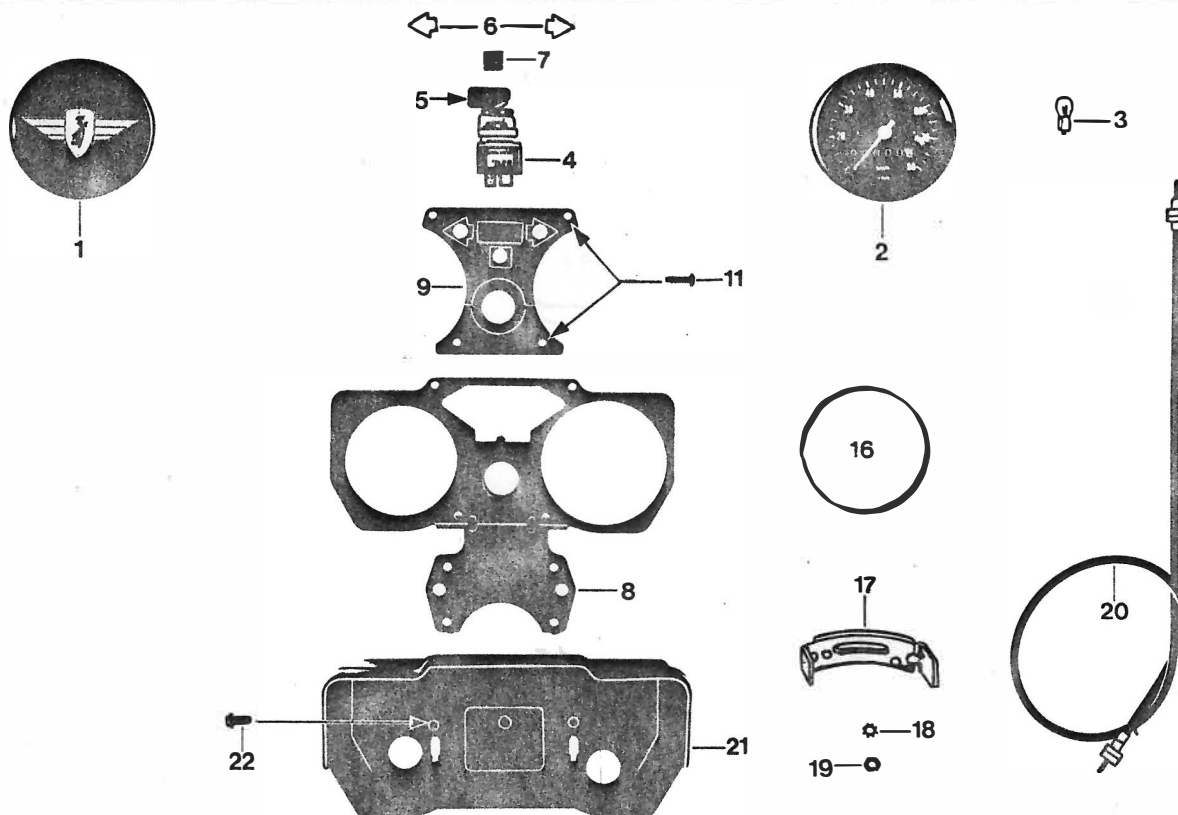

16.529.10

Afb.	Bestelnummer	Omschrijving	GTS	KS
1	529-16.182	Afsluitdeksel	1	1
2	529-16.915	Tellerklok $\varnothing$ 80, 80 km/h met afb. 3, 17, 18, 19	1	1
3	DIN 72601/520	Lampje J6V, 0,6 W	1	1
4	530-16.908	Kontaktschakelaar compl.	1	1
5	529-16.152	Kapje voor kontaktsleutel	1	1
6	517-16.668	Controlelampje geel	2	2
7	517-16.667	Controlelampje blauw	1	1
8	529-16.693	Drager	1	1
9	529-16.138	Plaatje	1	1
11	DIN 7981/440	Bout BZ 4,8x16	4	4
16	529-16.160	Ring $\varnothing$ 80	1	1
17	530-16.126	Beugel voor tellerklok	1	1
18	DIN 6797/240	Vulschijf A 5,3	2	2
19	DIN 934/320	Moer M 5	2	2
20	448-16.665	Tellerkabel M 10x1x755	1	1
21	529-16.140	Cockpithuis	1	1
22	529-16.164	Bout BZ 4,8x16	2	2

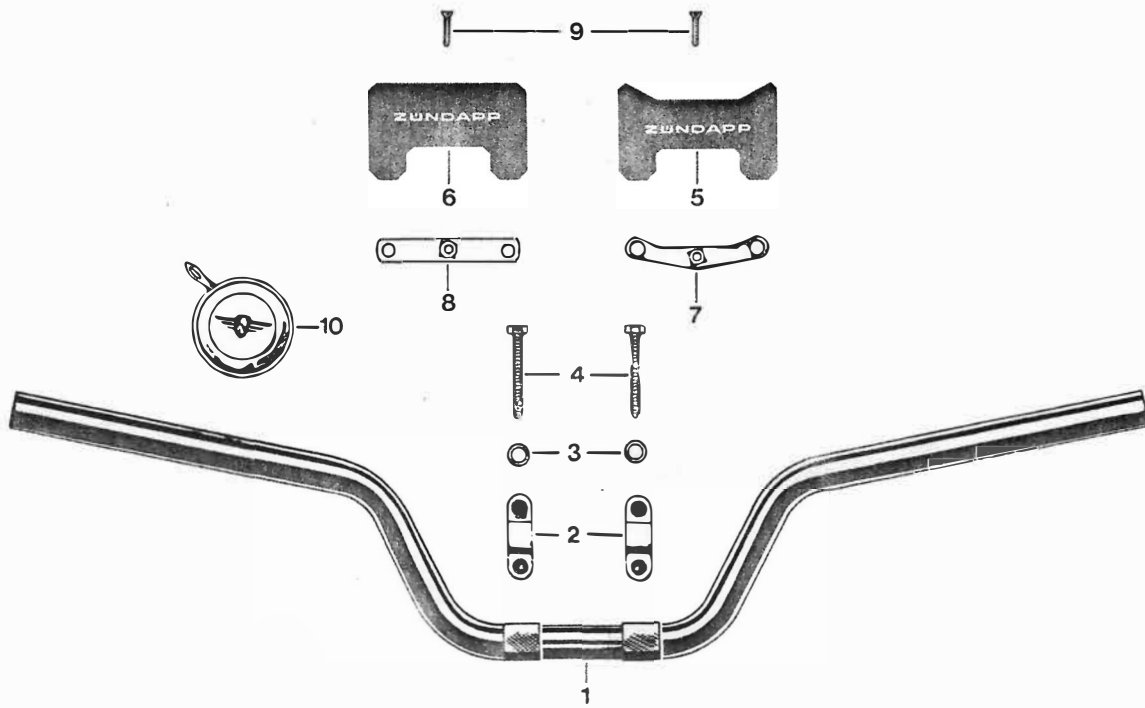

13.529.1

Afb.	Bestelnummer	Omschrijving	CS	GTS	KS
1	529-13.109	Stuur	1	1	1
2	529-13.100	Stuurklem	2	2	2
3	DIN 125/450	Vulschijf A 7,4	2	2	2
4	DIN 933/524	Bout M 7x50	4	4	4
5	529-13.102	Afdekplaatje	1	-	-
6	517-13.131	Afdekplaatje	-	1	1
7	529-13.600	Houder	1	-	-
8	517-13.615	Houder	-	1	1
9	DIN 964/440	Bout AM 5x20	1	1	1
10	400-17.610	Bel	1	1	1

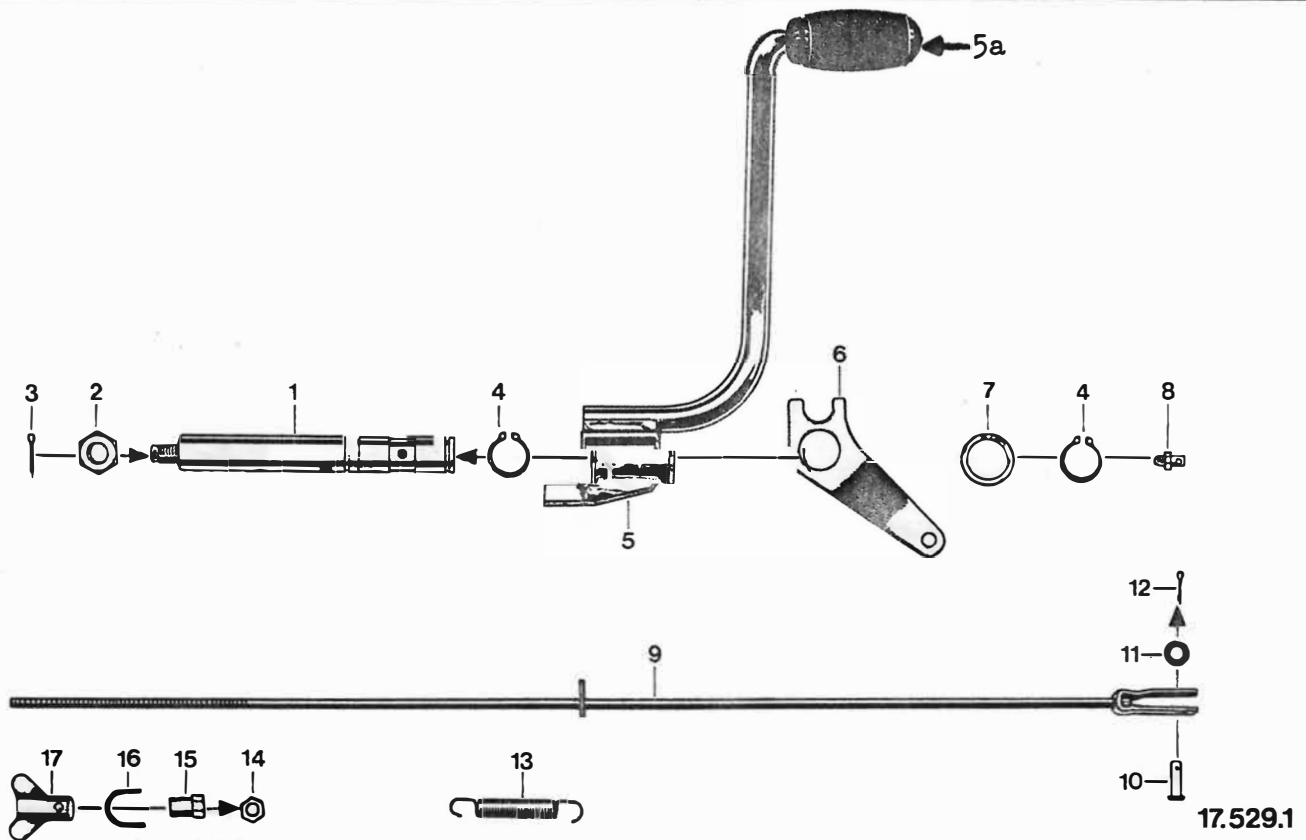

Afb.	Bestelnummer	Omschrijving	CS	GTS	KS
1	517-18.103	Pedaalas	1	1	1
2	DIN 936/560	Moer M 10x1	1	1	1
3	DIN 94/380	Splitpen 2x18	1	1	1
4	DIN 471/470	Borgveer 18x1,2	2	2	2
5	529-17.605	Voetrempedaal met rubber	1	-	-
5	529-17.631	Voetrempedaal met rubber	-	1	1
5a	616 z 25	Rubber	1	1	1
6	529-17.102	Meeneemplaats	1	1	1
7	517-17.110	Vulschijf	1	1	1
8	DIN 71412/400	Smeernippel AM 6	1	1	1
9	529-17.600	Remstang	1	1	1
10	519-17.106	Scharnierpen	1	1	1
11	DIN 125/400	Ring A 6,4	1	1	1
12	DIN 94/380	Splitpen 2x18	1	1	1
13	529-17.105	Remstang trekveer	1	1	1
14	DIN 934/410	Moer M 6	1	1	1
15	512-17.100	Moer	1	1	1
16	433-17.100	Remstangbeugel	1	1	1
17	428-17.103	Vleugelmoer	1	1	1

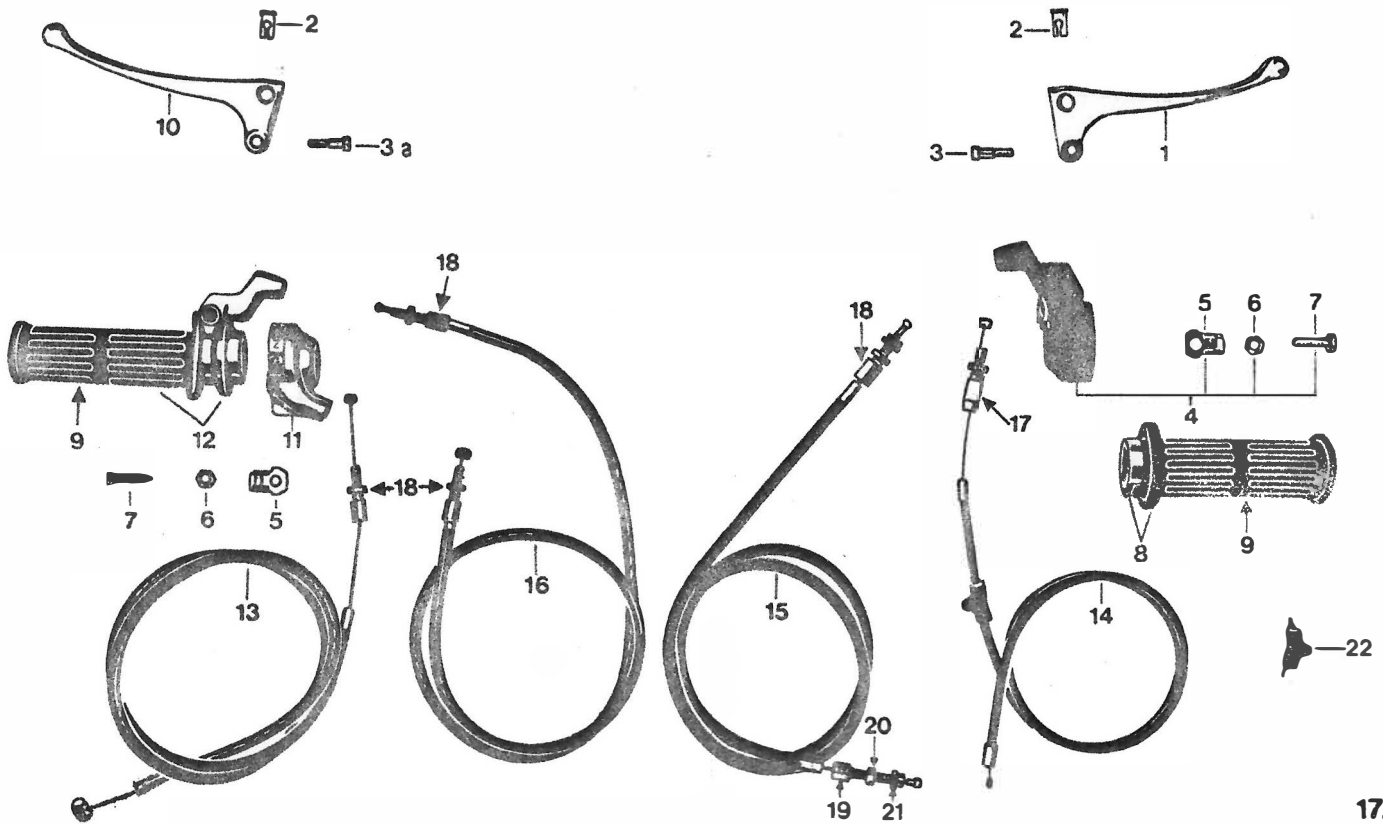

17.529.2

Afb.	Bestelnummer	Omschrijving	CS
-	529-17.704	Gashandle compleet	1
1	442-17.907	Remhandgreep	1
2	428-17.115	Nippelhouder	2
3	408-17.903	Handgreepbout	1
3a	510-17.911	Handgreepbout	1
4	517-17.904	Gashandlehuis	1
5	515-17.904	Haaksebevestigingsbeugel	2
6	515-17.907	Moer	2
7	515-17.913	Drukstift	2
8	529-17.900	Gashandle-draaigedeelte	1
9	446-17.905	Handvatrubber	2
-	529-17.707	Schakelhandle compleet	1
10	434-17.902	Koppelingshandgreep	1
11	433-17.901	Schakelhandlehuis	1
12	446-17.906	Schakelhandle draaigedeelte	1
13	529-17.627	Schakelkabel A 1,6x1060	1
14	529-17.628	Gaskabel A 1x943	1
15	529-17.609	Remkabel A 1,8x1081	1
16	529-17.608	Koppelingskabel A 1,6x975	1
17	515-17.719	Stelbout	1
18	428-17.715	Stelbout	4
19	400-17.141	Stelschroef	1
20	400-17.142	Moer	1
21	400-17.140	Stelring	1
22	521-17.607	Plastic smeernippel	1

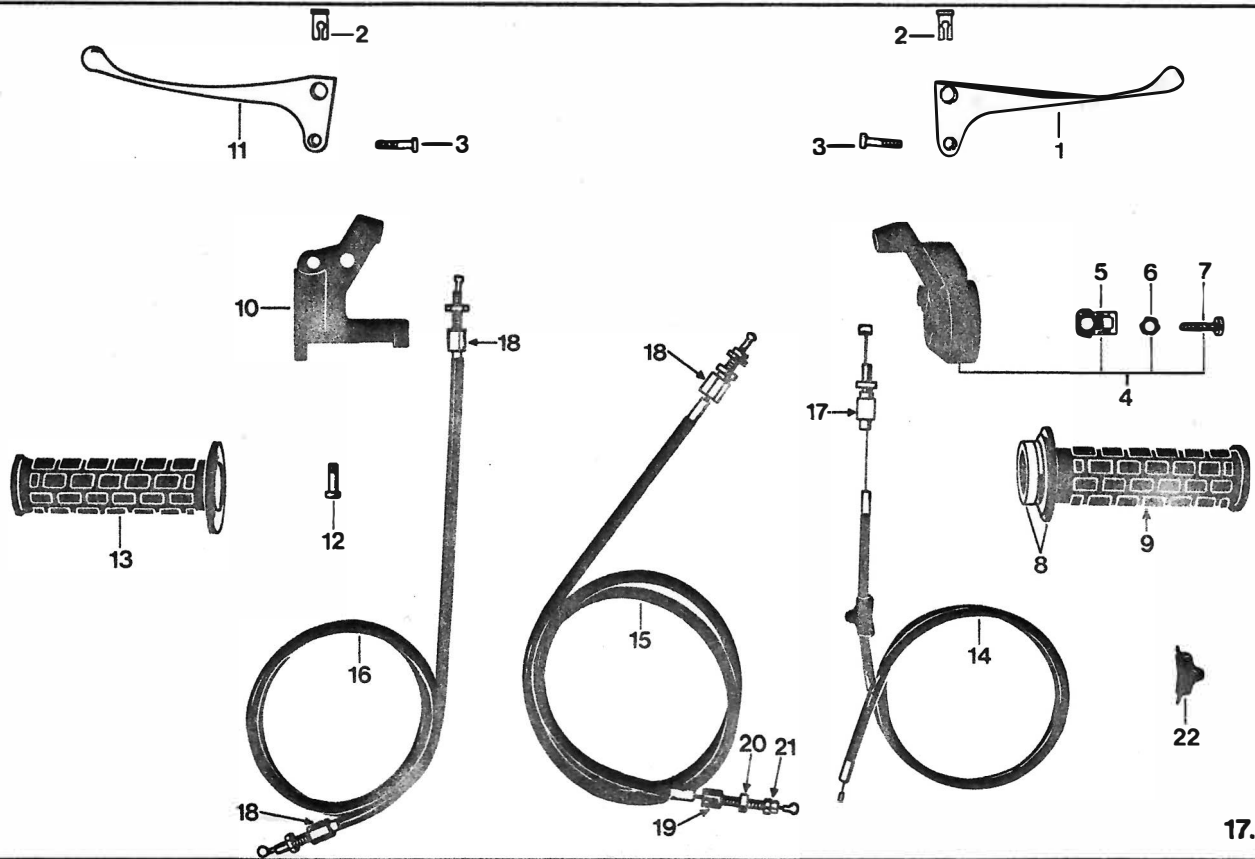

17.529.3

Afb.	Bestelnummer	Omschrijving	GTS
-	529-17.706	Gashandle compl.	1
1	517-17.909	Remhandgreep	1
2	428-17.115	Nippelhouder	2
3	408-17.903	Handgreepbout	2
4	529-17.713	Gashandlehuis	1
5	515-17.904	Haaksbevestigingsbeugel	1
6	515-17.907	Moer	1
7	515-17.913	Drukstift	1
8	529-17.901	Gashandle-draaigedeelte	1
9	529-17.902	Handvatrubber R.	1
-	517-17.739	Koppelingshandle compl.	1
10	517-17.922	Scharnierstuk	1
11	517-17.912	Koppelingshandgreep	1
12	400-17.912	Bout	1
13	529-17.113	Handvatrubber L.	1
14	529-17.607	Gaskabel A 1x950	1
15	529-17.609	Remkabel A 1,8x1081	1
16	529-17.608	Koppelingskabel A 1,6x972	1
17	515-17.719	Stelbout	1
18	428-17.715	Stelbout	3
19	400-17.141	Stelschroef	1
20	400-17.142	Moer	1
21	400-17.140	Stelring	1
22	521-17.607	Plastic smeernippel	1

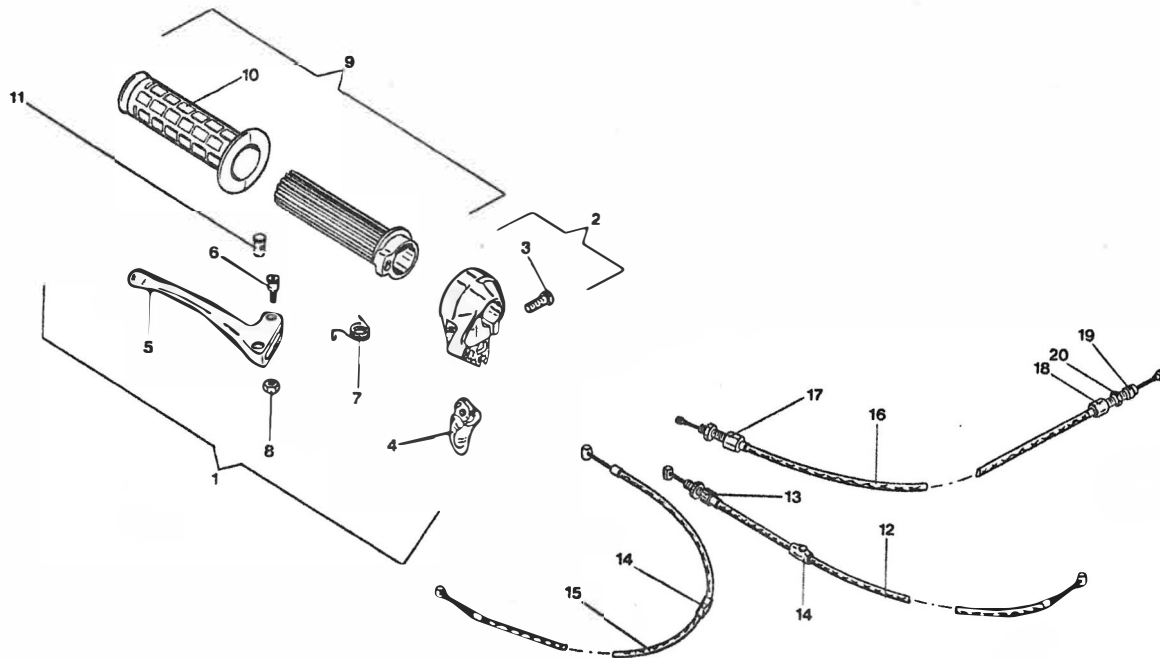
Helmrecht

17.448.3

Afb.	Bestelnummer	Omschrijving	GTS
1	529-17.718	Gashandle compl.	1
2	529-17.904	Gashandlehuis	1
3	400-17.912	Bout M 6x15	1
4	529-17.906	Starthandgreep	1
5	517-17.909	Remhandgreep	1
6	408-17.903	Handgreepbout M 5x19,5	1
7	529-17.907	Terugslagveer	1
8	447-17.901	Moer M 5	1
9	529-17.905	Gashandle-draaigedeelte	1
10	529-17.902	Handvatrubber	1
11	428-17.115	Nippelhouder	1
12	529-17.638	Gaskabel A 1x928	1
13	515-17.719	Stelbout	1
14	521-17.607	Plastic smeernippel	2
15	529-17.716	Startkabel A 1x870	1
16	529-17.635	Remkabel A 1,8x1082	1
17	428-17.715	Stelbout	1
18	400-17.141	Stelschroef	1
19	400-17.140	Stelring	1
20	400-17.142	Moer M 6	1

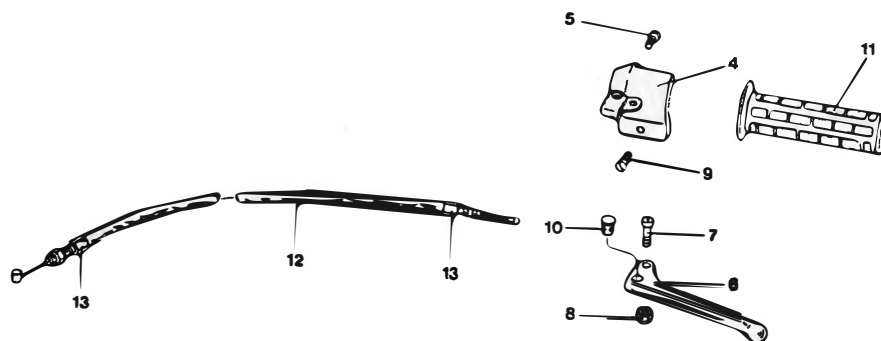

17.448.1

Afb.	Bestelnummer	Omschrijving	GTS
4-8	529-17.717	Koppelingshandle compl.	1
4-5	529-17.908	Scharnierstuk	1
5	400-17.912	Bout M 6x15	1
6	517-17.912	Koppelingshandgreep	1
7	408-17.903	Handgreepbout M 5x19,5	1
8	447-17.901	Moer M 5	1
9	DIN 963/520	Bout M 4x20	1
10	428-17.115	Nippelhouder	1
11	529-17.113	Handvatrubber	1
12	529-17.608	Koppelingskabel A 1,6x975	1
13	428-17.715	Stelbout	2

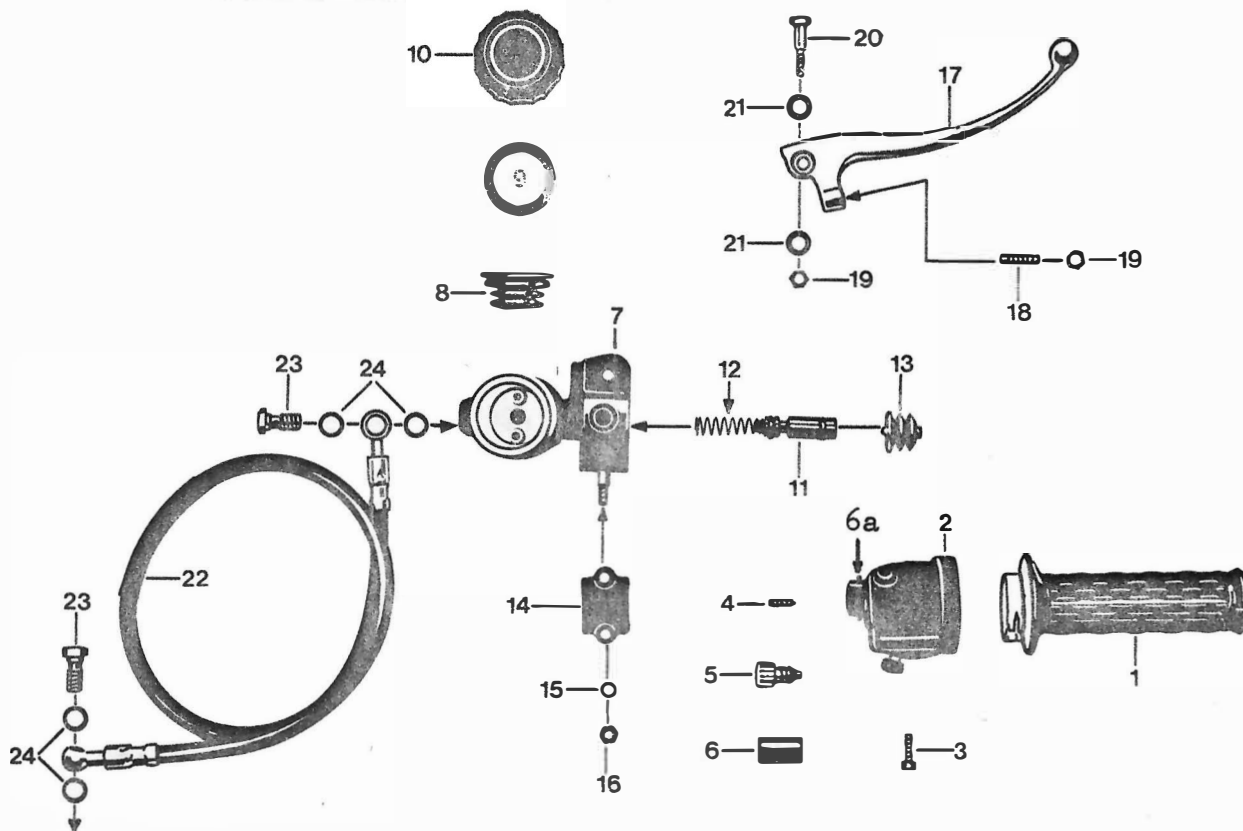

17.530.6

Afb.	Bestelnummer	Omschrijving	KS
1-6	530-17.755	Gashandle compl.	1
1	530-17.607	Gashandle-draaigedeelte	1
2	530-17.752	Gashandlehuis compl.	1
3	DIN 912/260	Bout M 5x25	2
4	DIN 553/480	Bout M 5x16	1
5	530-17.735	Bout compl.	1
6	530-17.104	Plaatje	1
6a	530-17.126	Stekkerhuisje	1
7-21	530-17.746	Remcilinder compl.	1
7	530-17.608	Remhuis compl.	1
8	530-17.122	Balg	1
9	530-17.121	Ring	1
10	530-17.120	Vuldoop	1
11+12	530-17.747	Zuiger compl.	1
12	530-17.116	Drukveer	1
13	530-17.609	Drukstift met hoesje	1
14	530-17.123	Klem	1
15	DIN 433/400	Vulschijf A 6,4	2
16	517-22.111	Moer M 6	2
17-19	530-17.748	Remhandgreep compl.	1
18	530-17.117	Stelbout	1
19	442-15.916	Moer	2
20	530-17.118	Bout voor handgreep	1
21	530-17.119	Vulschijf	2
22-24	530-17.702	Remleiding compl.	1
23	530-17.911	Banjo-bout M 10x1	2
24	530-17.912	Afdichtring 10x14	4



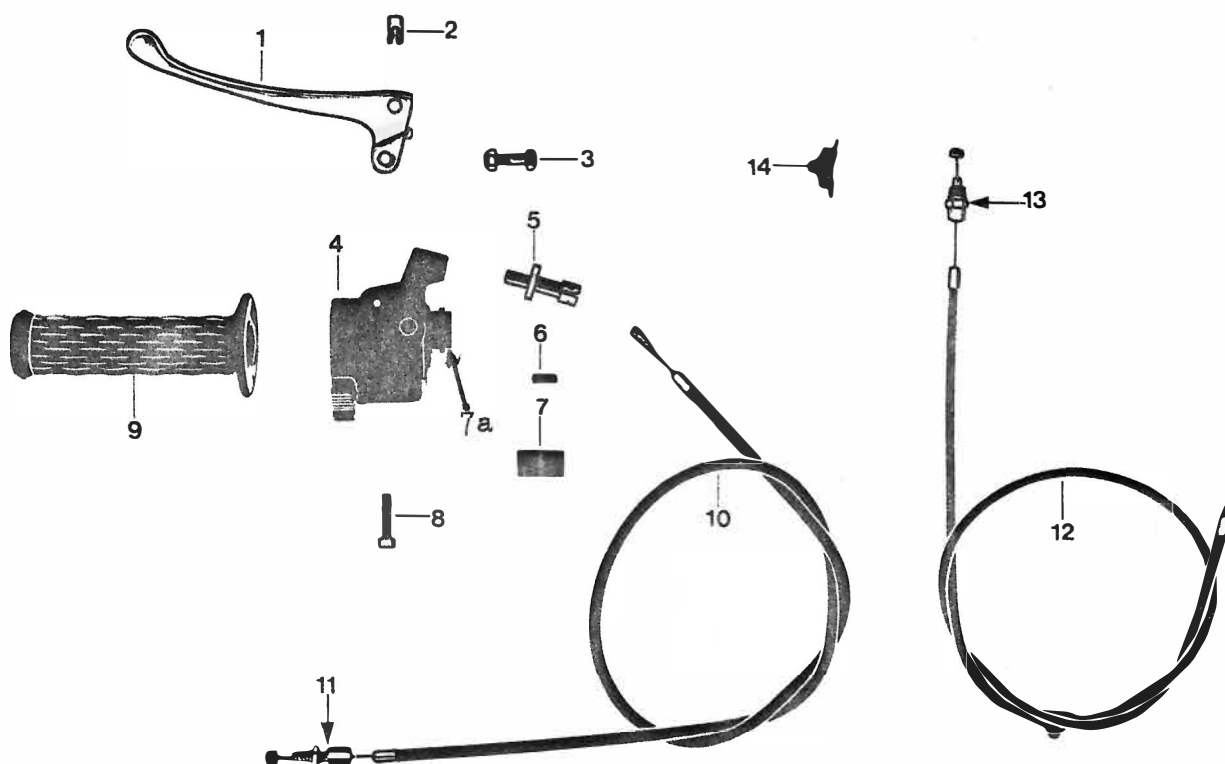

17.530.4

Afb.	Bestelnummer	Omschrijving	KS
1-8	530-17.760	*Koppelingshandle compl. zonder starthandgreep	1
1-8	529-17.721	**Koppelingshandle compl. met starthandgreep	1
1	530-17.128	Koppelingshandgreep	1
-	529-17.117	**Starthandgreep	1
-	529-17.118	**Starthandgreepbout M 4x13,2	1
2	428-17.115	Nippelhouder	1
3	530-17.734	Koppelingshandgreepbout SW 10	1
4	530-17.750	Koppelingshuis compl.	1
5	530-17.733	Bout	1
6	DIN 553/480	Bout M 5x16	1
7	530-17.125	Plaatje	1
7a	530-17.126	Stekkerhuisje	1
8	DIN 912/260	Bout M 5x25	1
9	530-17.109	Handvatrubber	1
10	530-17.603	Koppelingskabel A 1,6x950	1
11	428-17.715	Stelbout	1
12	529-17.634	*Gaskabel A 1x977	1
12	529-17.637	**Gaskabel A 1x968	1
13	517-17.180	Stelbout	1
14	521-17.607	Plastic smeernippel	1
--	529-17.719	**Startkabel A 1x807	1

\*tot framennr. 9 315 844

\*\*vanaf framennr. 9 315 845

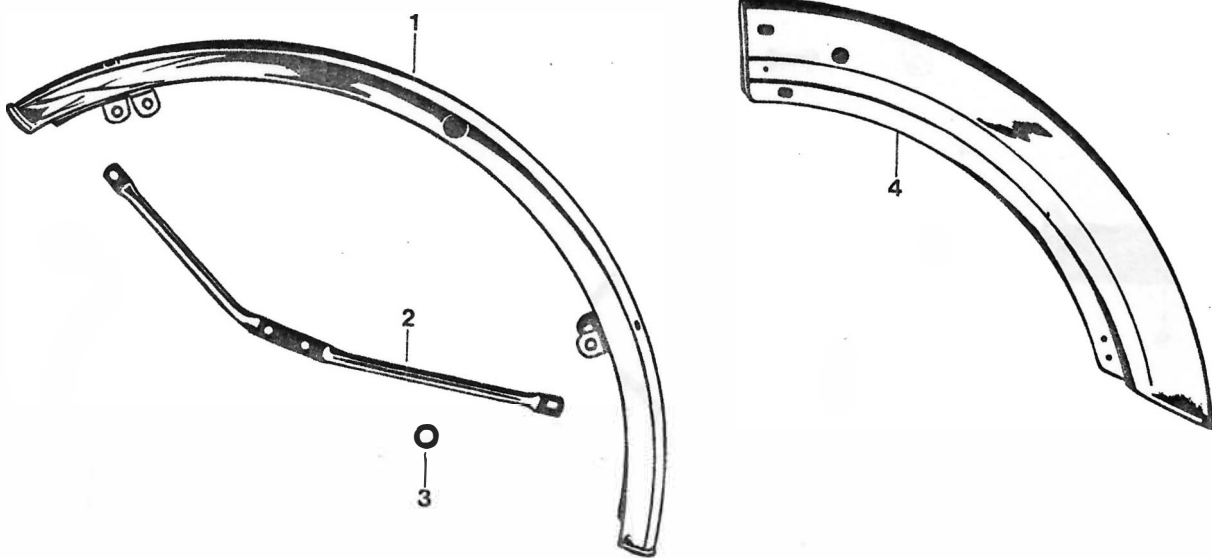

19.529.2

Afb.	Bestelnummer	Omschrijving	CS	GTS
1	529-19.607 <u>kleur</u>	Voorspatscherm	1	1
1	530-19.900	Voorspatscherm - verchroomd -	n.	beh.
2	529-19.109	Beugel links	1	1
-	529-19.110	Beugel rechts	1	1
-	DIN 7985/264	Bout AM 6x10	4	4
-	DIN 6797/400	Vulschijf A 6,4	4	4
-	DIN 933/320	Bout M 6x12	4	4
-	517-22.111	Moer M 6	4	4
3	1236 z 06	Rubber	1	1
4	529-19.613	Achterspatscherm - zwart -	1	1
4	529-19.612	Achterspatscherm - verchroomd -	n.	beh.
-	529-19.106	Wit oplegstrip voor achterspatscherm	1	1
-	DIN 84/435	Bout AM 6x16	4	4
-	DIN 933/350	Bout M 6x18	2	2
-	1301 z 1019	Vulschijf 6,2x22x1	2	2
-	DIN 125/400	Vulschijf A 6,4	2	2
-	DIN 137/360	Veerring B 6	6	6
-	DIN 934/410	Moer M 6	6	6

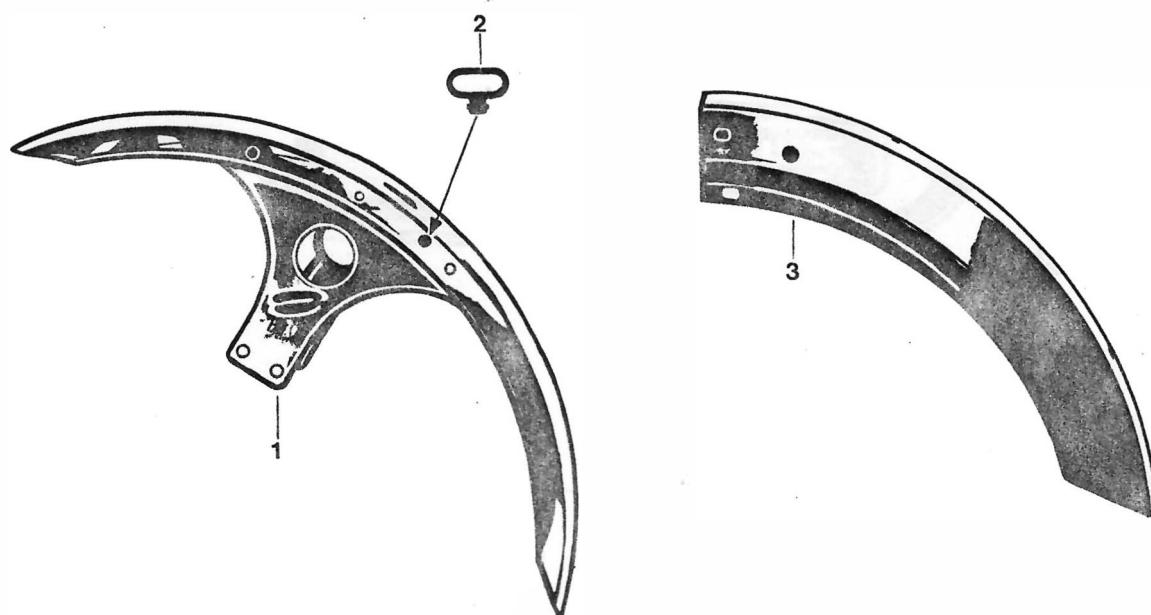

19. 530. 1

Afb.	Bestelnummer	Omschrijving	KS
1	448-19.600	Voorspatscherm - verchroomd -	1
2	530-19.101	Houder voor remleiding	2
-	DIN 933/320	Bout M 6x12	4
-	DIN 6797/400	Vulschijf A 6,4	4
-	DIN 125/400	Vulschijf A 6,4	4
3	529-19.613	Achterspatscherm - zwart -	1
3	529-19.612	Achterspatscherm - verchroomd -	n. beh.
-	529-19.106	Wit oplegstrip voor Achterspatbord	1
-	DIN 84/435	Bout AM 6x16	4
-	DIN 933/350	Bout M 6x18	2
-	1301 z 1019	Vulschijf 6,2x22x1	2
-	DIN 125/400	Vulschijf A 6,4	2
-	DIN 137/360	Veerring B 6	6
-	DIN 934/410	Moer M 6	6

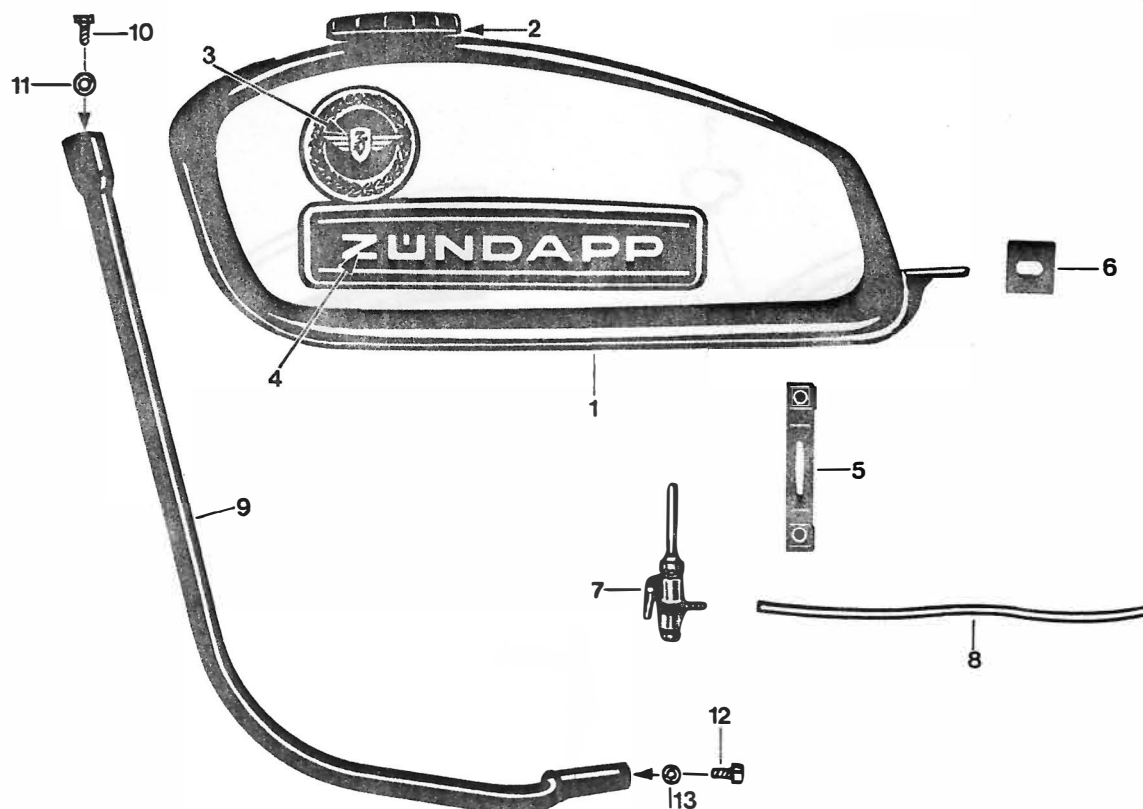

20.529.2

Afb.	Bestelnummer	Omschrijving	CS	GTS	KS
1	529-20.706 <u>kleur</u>	Benzinetank zonder benzinekraan	1	1	1
2	529-20.602	Tankdop	1	1	1
3	529-20.118	Tankembleem	2	2	2
4	529-20.123 <u>kleur</u>	Transfer " ZÜNDAPP "	2	2	2
-	529-20.114	Tanktransfer	1	1	1
-	517-20.153	Transfer " Trophy "	1	1	1
5	529-20.109	Rubber buffer	1	1	1
6	529-20.105	Rubber buffer	1	1	1
7	428-20.712	Benzinekraan compl.	1	1	1
8	DIN 73379/410	Benzineslang A 5x9x620	1	1	1
9	529-10.655	Beugel links	-	1	1
-	529-10.656	Beugel rechts	-	1	1
10	DIN 933/554	Bout M 8x16	-	2	2
11	DIN 127/560	Veerring B 8	-	2	2
12	DIN 912/520	Bout M 8x16	-	2	2
13	DIN 7980/500	Veerring B 8	-	2	2
--	517-20.752	Gereedschap-set	1	1	1
--	517-20.603	Bougie sleutel SW 17/21	1	1	1
--	444-20.600	Luchtpomp	1	1	1

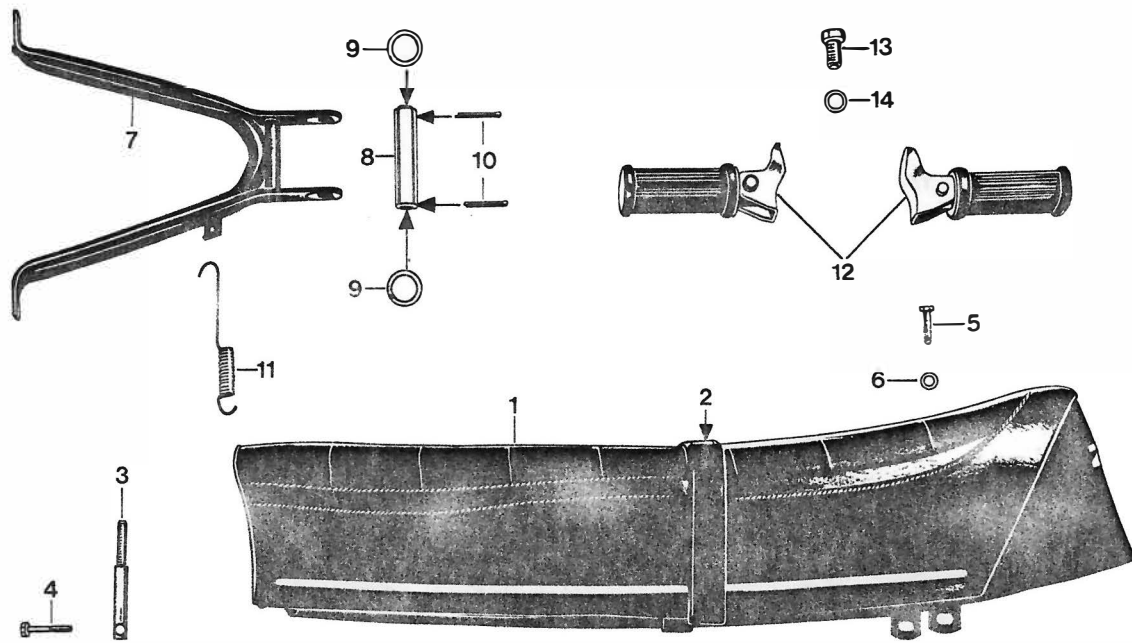

21.529.1

Afb.	Bestelnummer	Omschrijving	CS
1	529-21.605	Buddyseat	1
2	529-21.900	Buddyseatriem	1
3	517-21.104	Buddyseatbout	1
4	DIN 931/300	Bout M 6x35	1
-	400-20.106	Vulschijf 6,4x14x1,5	1
5	DIN 933/470	Bout M 7x25	2
6	DIN 127/480	Veerring B 7	2
7	517-21.608	Middenstandaard	1
8	517-21.116	Standaardbus	1
9	517-21.113	Vulschijf	2
10	DIN 94/650	Splitpen 3,2x28	2
11	517-21.109	Standaardveer	2
12	425-14.670	Duo-voetsteunen ( stel )	1
13	DIN 933/670	Bout M 10x18	2
14	DIN 127/640	Veerring B 10	2

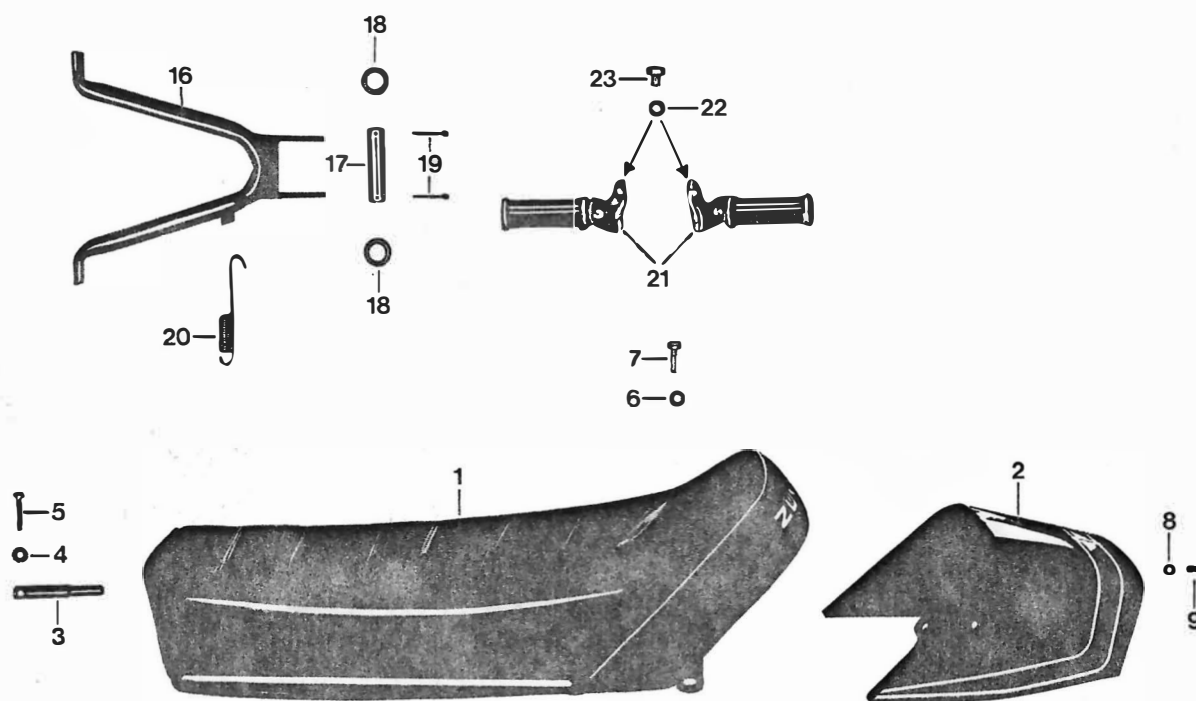

21.530.1

Afb.	Bestelnummer	Omschrijving	GTS	KS
1	530-21.609	Buddyseat	1	1
2	529-21.604 <u>kleur</u>	Spoiler	1	1
-	530-21.102	Transfer voor spoiler	1	1
3	517-21.104	Buddyseatbout	1	1
4	400-20.106	Vulschijf 6,4x14x1,5	1	1
5	DIN 931/300	Bout M 6x35	1	1
6	DIN 127/480	Veerring B 7	2	2
7	DIN 933/470	Bout M 7x25	2	2
8	DIN 137/352	Veerring B 6	3	3
9	DIN 933/350	Bout M 6x18	3	3
-	529-16.122	Reflector voor spoiler	1	1
-	DIN 84/350	Bout AM 5x14	2	2
-	DIN 137/320	Veerring A 5	2	2
16	517-21.608	Middenstandaard	1	1
17	517-21.116	Standaardbus	1	1
18	517-21.113	Vulschijf	2	2
19	DIN 94/650	Splitpen 3,2x28	2	2
20	517-21.109	Standaardveer	2	2
21	425-14.670	Duo-voetsteunen ( stel )	1	1
22	DIN 127/640	Veerring B 10	2	2
23	DIN 933/670	Bout M 10x18	2	2

Toebehoren / Cockpit-bekleding

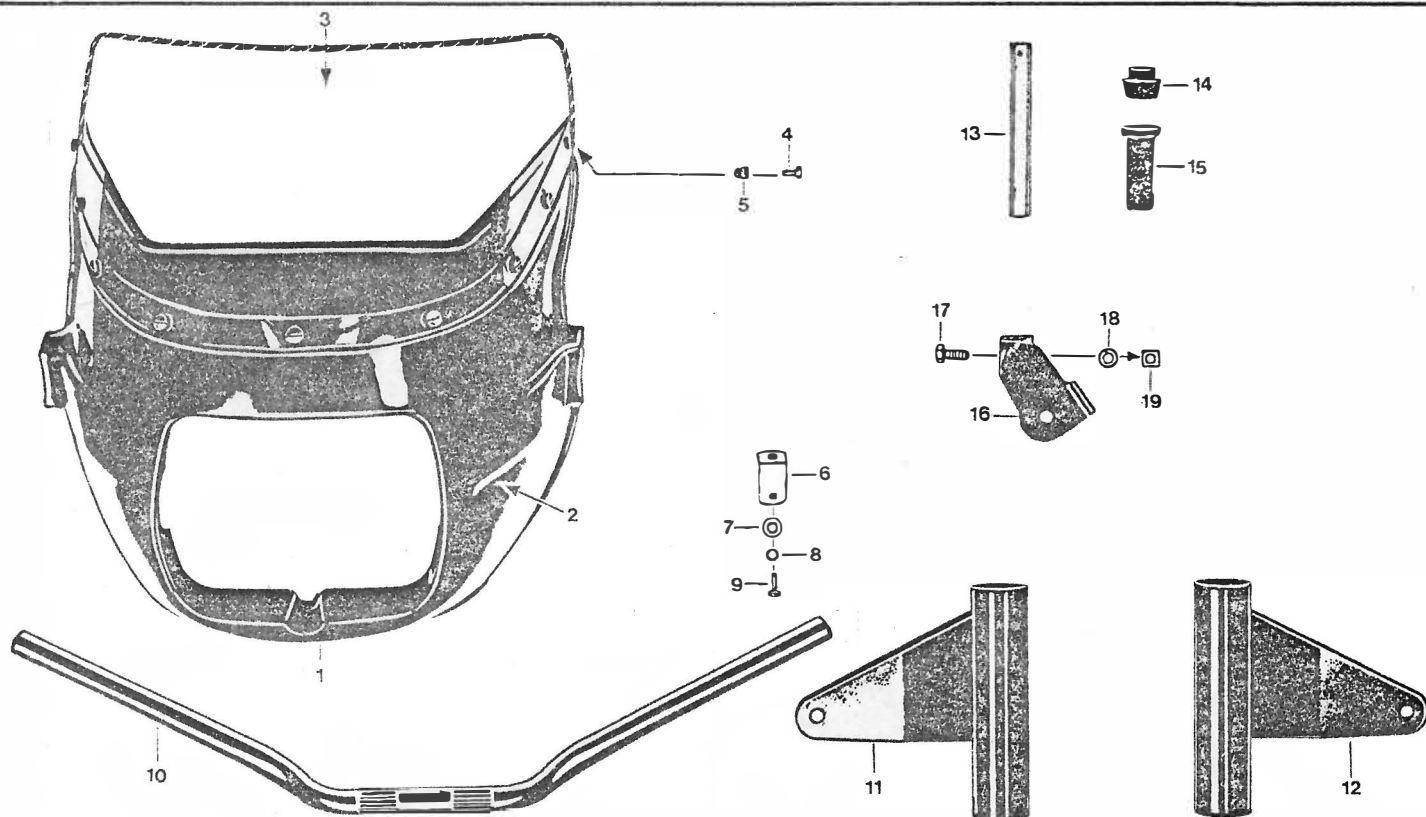

Afb.	Bestelnummer	Omschrijving	Aantal
1-19	529-23.902 <u>kleur</u>	Cockpit-bekleding compl. met bevestigingen	1
1-5	530-19.701 <u>kleur</u>	Cockpit-bekleding compl.	1
2	530-19.118 <u>kleur</u>	Cockpit-bekleding kaal	1
3	530-19.117	Plexiglas	1
4	DIN 85/510	Bout M 6x12	9
5	DIN 1587/125	Moer M 6	9
6	530-19.609	Borgplaat	2
7	DIN 9021/600	Vulschijf A 6,4	2
8	DIN 127/400	Veerring B 6	2
9	DIN 7985/275	Bout M 6x16	2
10	530-13.101	Stuur	1
11	530-16.637 <u>kleur</u>	Koplamphouder links	1
12	530-16.638 <u>kleur</u>	Koplamphouder rechts	1
13	530-16.119	Knipperlichtstang voor	2
14	530-16.120	Rubber	2
15	530-16.121	Afstandsbus	2
16	530-16.636	Houder knipperlicht rechts voor	1
--	530-16.635	Houder knipperlicht links voor	1
17	DIN 933/453	Bout M 7x16	2
18	DIN 127/480	Veerring B 7	2
19	530-16.123	Moer M 7	2



**ZÜNDAPP-WERKE GMBH MÜNCHEN**