

ZUNDAPP

SPARE PARTS LIST

SCOOTER

R 204 Bella

with electric starter

ZUNDAPP

SPARE PARTS LIST

SCOOTER

R 204 Bella

with electric starter

beginning with Frame No. R 127 001

www.zundappveteranenclub.nl

Contents

| | Page | Illustration |
|---|------|--------------|
| Introduction | 4 | — |
| Group M: | | |
| a) Engine (assembly) | 9 | 1 |
| b) Housing and Cylinder | | |
| Crankcase | 11 | 2 |
| Crankcase cover | 15 | 3 |
| Cylinder and Cylinder head | 17 | 4 |
| c) Drive mechanism | | |
| Crankshaft, Connecting rod, Piston | 1 | 5 |
| f) Carburettor | 21 | 6 |
| Intake silencer | 25 | 7 |
| g) Clutch, Clutch operating mechanism | 27 | 8 |
| Group G: | | |
| c) Shafts and gears | | |
| Selector shaft | 29 | 9 |
| Layshaft | 31 | 9 |
| d) Footshift mechanism | 33 | 10 |
| Group R: | | |
| a) Frame | 37 | 11 |
| Front engine carrier, Center stand | 39 | 12 |
| Rear engine carrier with swinging fork | 41 | 13 |
| b) Foot boards, Folding grids and Side stand | 45 | 14 |
| d) Mudguards | | |
| Front mudguard | 47 | 15 |
| Rear mudguard and Chain case | 49 | 16 |
| e) Body | | |
| Front shield | 53 | 17 |
| Front cover and Dashboard with cover | 55 | 18 |
| Rear body | 57 | 19 |
| Dual seat | 61 | 20 |
| f) Fuel tank and fuel pipes | 63 | 21 |
| h) Exhaust | 65 | 22 |
| i) Front swinging arm suspension | 67 | 23 |
| k) Handlebar and Hand levers with operating cables | 71 | 24 |
| Group B: | | |
| a) Brakes | | |
| Handbrake | 75 | 25 |
| Footbrake | 77 | 26 |
| b) Wheels | 81 | 12 |
| Group E: | | |
| a) Electrical equipment | | |
| Headlamp, Battery, Dashboard, Taillight, Horn, Wires | 83 | 28 |
| Starter generator | 89 | 29 |
| Group W: | | |
| a) Tools | 91 | 30 |
| b) Toolbox | 93 | 31 |

Designs text and illustrations subject to change

ZUNDAPP-WERKE GMBH - MÜNCHEN
München 8, Anzinger Straße 1-3

Printed in Germany

W 2445aM**

Published in June 1959

INTRODUCTION

Comments to the Catalogue of Spares, Foreign Service only!

When ordering Spare Parts from this Catalogue of Spares, please state or note the following in each case:

1. Ordering

All communications relating to spare parts, please address only to:

ZUNDAPP-WERKE GMBH MÜNCHEN

Export Departement

München 8, Germany

Anzinger Straße 1-3

When ordering by telephone, please call up Munich 44 32 21, extension station 257 (Foreign Service). With all orders **only** the "Serial No." given in the first column of the Spare Parts Catalogue, and the number of parts desired should be stated. **Please quote also the Type of engine!**

It is unnecessary to give the denomination of the part and the component No. Exception should be made when ordering spares which do not appear in this Catalogue (Special Designs!).

Please make use of the following formula:

Address as above

Model order

Re. Frame No. 127 325

| | |
|----------------|----------------|
| 1 crankshaft | No. 1950 k 211 |
| 1 cylinder | No. 2162 z 218 |
| 1 piston | No. 883 z 169 |
| 2 piston rings | No. 1262 z 107 |

Stamp and signature

If any part cannot be identified for certain by its Serial-No., please send us a sample provided with your full **address, but do not join your order or your comments to the sample!**

If return of parts sent to us samples is desired, this should be clearly stated in the order and by a tag attached to the sample itself. We do not keep old parts. We deposit them immediately without differentiation and without credit on our scrap heap.

2. Prices

The gross prices in DM, each, are to be taken from separate price lists. In these, the stars printed after the piece indicate:

| | |
|--------------|--------------------|
| Without star | — Discount Group 1 |
| with 1 star | — Discount Group 2 |
| with 2 stars | — Discount Group 3 |

All prices are to be understood free German Border or FOB German Seaport, packing included. **The local Foreign Parcel Post Offices are Border Stations!**

3. Despatch Instructions, Freight and Packing

When ordering spares, please state clearly your Despatch Instructions, i. e.: Samples of no value, parcel post, freight goods, fast goods, express, express-parcel, airmail or air freight.

Also give your full address as otherwise delays are unavoidable. Orders below DM 3.— are not subject to Trade Discount.

4. Payment Terms

If payment is not made in advance or if a Ledger Account does not exist, the goods will be sent C.O.D. without exception. With the best will in the world, we cannot depart from this as, with our large number of customers running into thousands, our Book-Keeping Departement cannot open special accounts.

In principle it is not possible to take back and credit at a later date spare parts ordered and delivered.

5. General

a) Place spare part orders separately; not with other letters!

b) In all replies to our letters, kindly quote our Dept. and letter references. Your business is thereby facilitated and prompt reply to your enquiries and queries assured.

6. Conditions of Guarantee

Please refer to our "Service Informations" and our Service Manual.



R 204, right-hand view
beginning with Frame No. R 127 001



R 204, left-hand view
beginning with Frame No. R 127 001

Illustration 1, Group M: a) Engine (assembly)

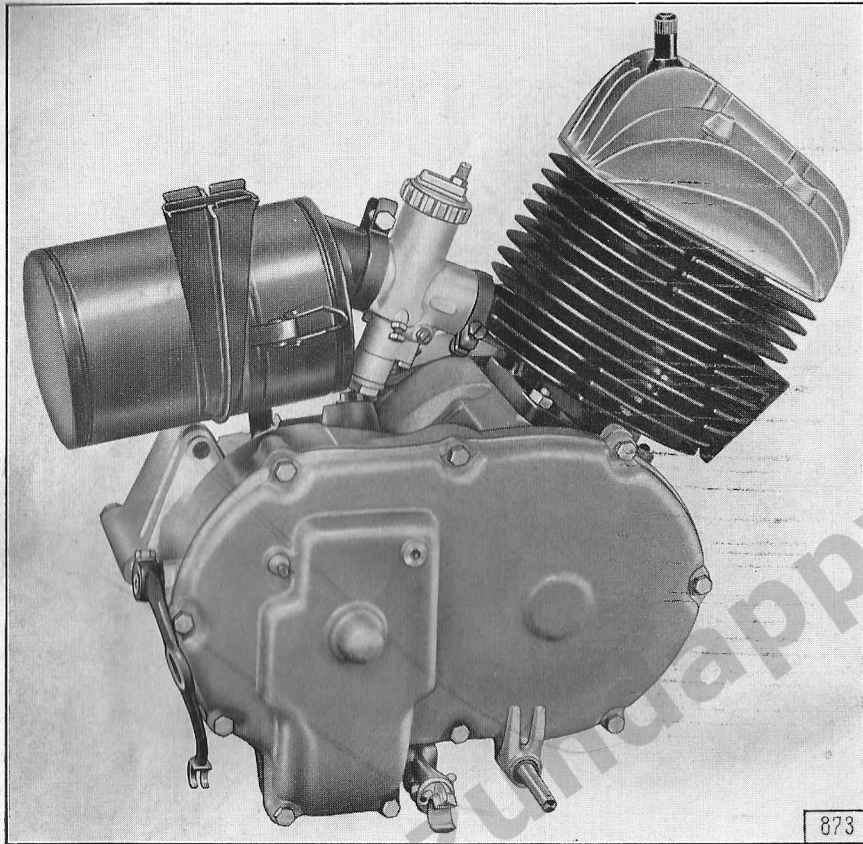

Illustration 1, Group M: a) Engine (assembly)

| Key No. | Spare Part No. | Description | Quantity | Remarks |
|---------|----------------|---|----------|---------|
| — | 6950 k 245 | <p style="text-align: center;">Engine</p> Engine complete with starter generator and carburettor | 1 | |

Illustration 2, Group M: Housing and Cylinder, Crankcase

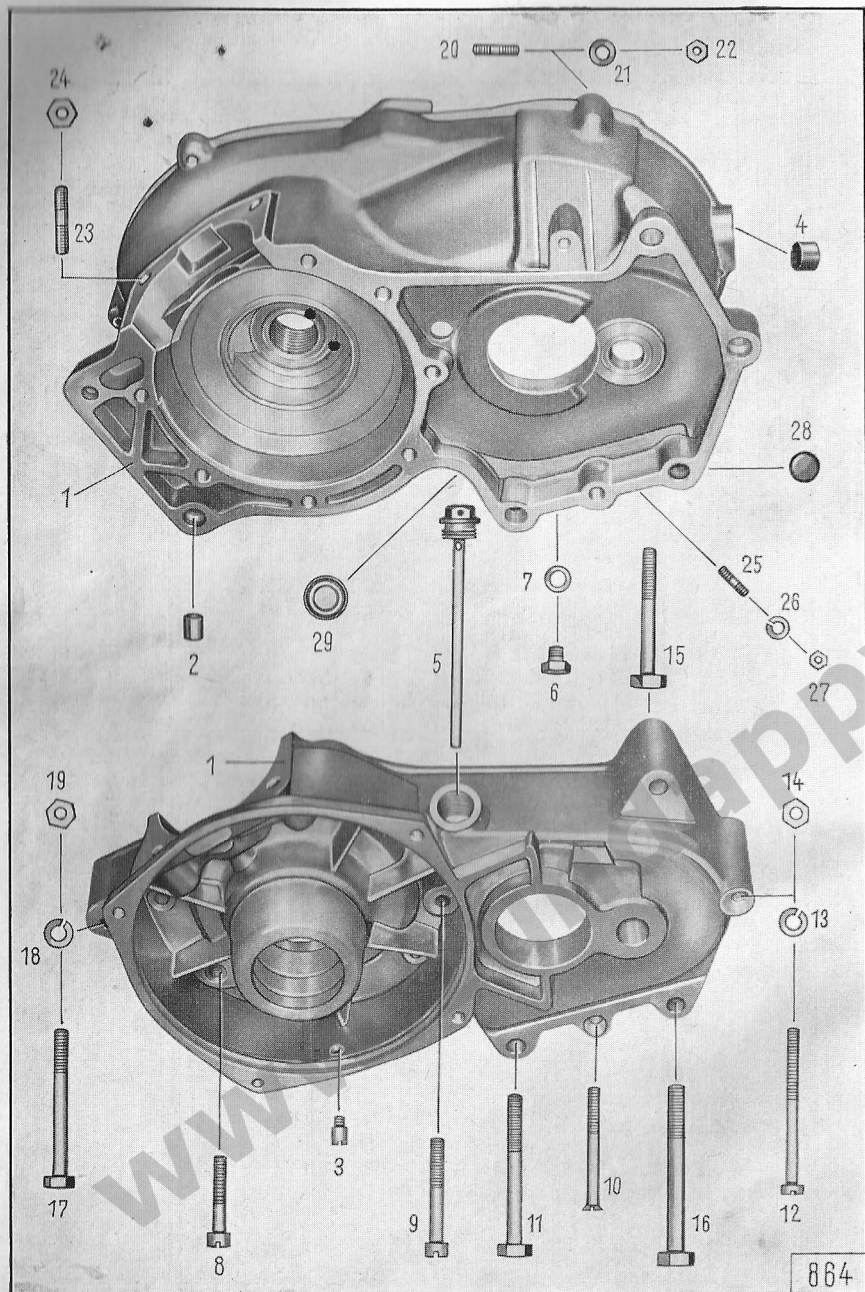

Illustration 2, Group M: Housing and Cylinder, Crankcase

| Key No. | Spare Part No. | Description | Quantity | Remarks |
|------------------|----------------|---|----------|----------|
| Crankcase | | | | |
| 1 | 510 k 245 | crankcase complete | 1 | |
| 2 | 181 z 18 | Bushing (between left and right of crankcase | 2 | |
| 3 | 1331 z 839 | ags escape pipe | 1 | |
| 4 | 184 z 328 | bearing bushing (for clutch pressure bar) | 1 | |
| 5 | 1550 z 109 | oil dip stick (for gearbox) | 1 | |
| 6 | — | hex. screw M 8 x 10 DIN 933 (for oil drain) | 3 | |
| 7 | — | Seal C 8 x 14 DIN 7603 | 3 | |
| 8 | — | cylindrical screw M 8 x 40 DIN 912 K (to fasten left half to right half of crankcase) | 6 | |
| 9 | — | cylindrical screw M 8 x 55 DIN 912 k (to fasten left half to right half of crankcase) | 1 | |
| 10 | — | raised head screw M 8 x 65 DIN 91 k (to fasten left half to right half of crankcase) | 1 | old type |
| — | — | hex. screw M 8 x 70 DIN 931 z (to fasten left half to right half of crankcase) | 1 | new type |
| 11 | — | hex. screw M 10 x 80 DIN 931 k (to fasten left half to right half of crankcase) | 1 | |
| — | — | spring washer B 10 DIN 137 k | — | |
| — | — | hex. nut M 10 DIN 934 k | 1 | |
| 12 | — | cylindrical screw CM8x85 DIN 84 k (to fasten left half to right half of crankcase and to the rear engine carrier) | 1 | |
| 13 | — | lock ring A 8 DIN 127 k | 1 | |

Illustration 2, Group M: Housing and Cylinder, Crankcase

| Key No. | Spare Part No. | Description | Quantity | Remarks |
|---------|----------------|---|----------|---------|
| 14 | — | hex. nut M 8 DIN 934 k | 1 | |
| 15 | — | hex. screw M 10 x 75 DIN 931 k (to fasten crankcase to rear engine carrier) | 1 | |
| 16 | — | hex. screw M 10 x 90 DIN 931 k (to fasten crankcase to rear engine carrier) | 1 | |
| — | — | lock ring A 10 DIN 127 k | 2 | |
| — | — | hex. nut M 10 DIN 934 k | 2 | |
| 17 | — | hex. screw M 8 x 80 DIN 931 k (to fasten crankcase to front engine suspension plates) | 2 | |
| 18 | — | lock ring A 8 DIN 127 k | 2 | |
| 19 | — | hex. nut M 8 DIN 934 k | 2 | |
| 20 | — | stud M 6 x 12 DIN 835 z (to fasten intake silencer) | 1 | |
| 21 | — | lock washer B 6 DIN 137 z | 1 | |
| 22 | — | hex. nut M 6 DIN 934 z | 1 | |
| 23 | 1561 z 10 | stud (to fasten cylinder) | 4 | |
| 24 | — | hex. nut M 8 DIN 934 k | 4 | |
| 25 | 1561 z 107 | stud (for fixing gear selector support) | 4 | |
| 26 | — | lock ring A 5 DIN 127 k | 4 | |
| 27 | — | hex. nut M 5 DIN 934 k | 4 | |
| 28 | — | sealing washer 16 DIN 470 (to right half of crankcase) | 1 | |
| 29 | — | radial gasket B 14 x 24 x 7 DIN 6503 (to footshift shaft) | 1 | |

Illustration 3, Group M: Housing and Cylinder, Housing cover

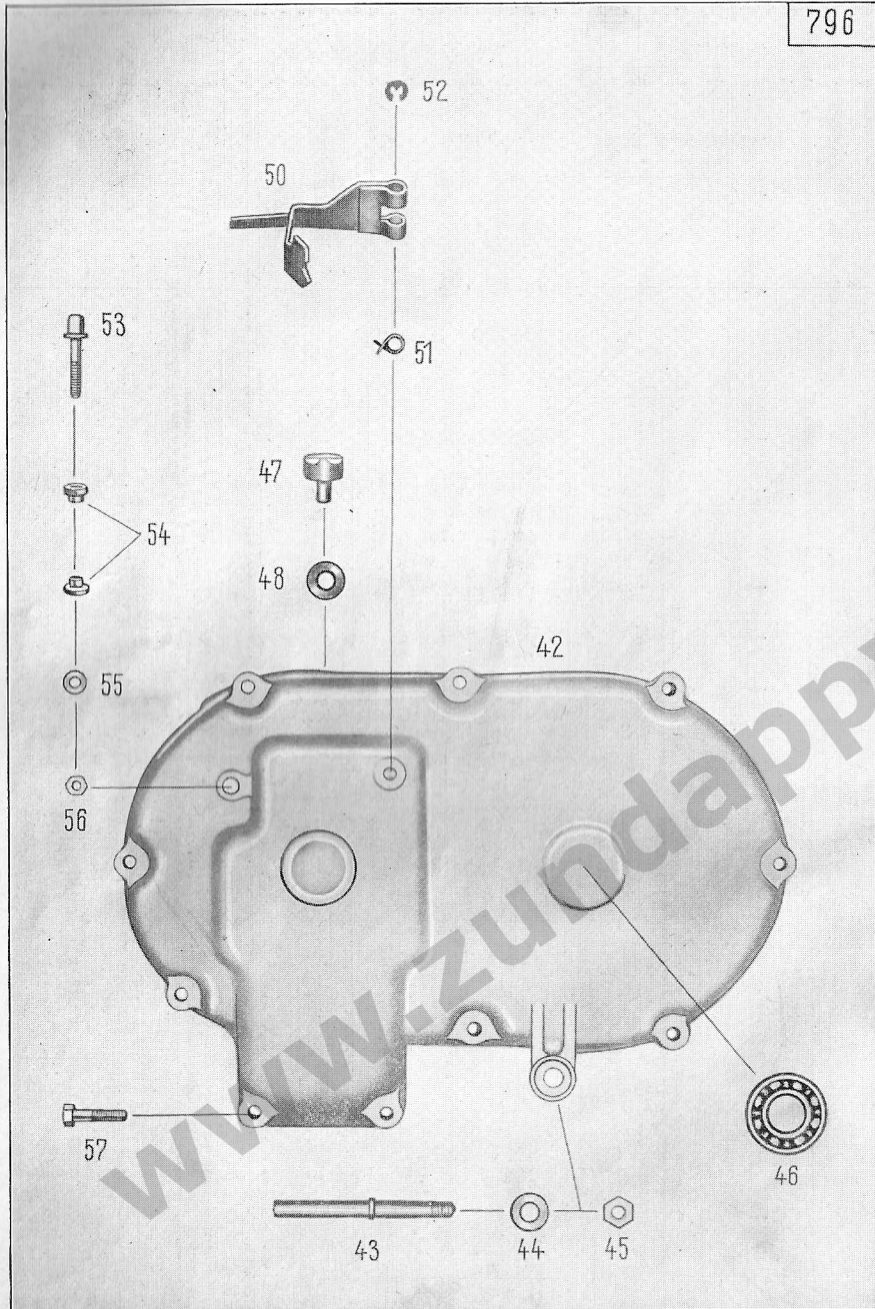

Illustration 3, Group M: Housing and Cylinder, Housing cover

| Key No. | Spare Part No. | Description | Quantity | Remarks |
|------------------------|----------------|--|----------|---------|
| Crankcase Cover | | | | |
| 42 | 260 z 40 | crankcase cover | 1 | |
| 43 | 121 z 1122 | bolt | 1 | |
| 44 | — | lock washer A 8 DIN 137 k | 1 | |
| 45 | — | hex. nut M 8 DIN 934 k | 1 | |
| 46 | — | ball bearing 6203 DIN 625 | 1 | |
| 47 | 1121 z 32 | supporting bolt | 1 | |
| 48 | 1301 z 52 | compensating washer } for | var. | |
| — | 1301 z 616 | compensating washer } supporting | | |
| 50 | 670 z 205 | contact breaker arm (for idle check light) | 1 | |
| 51 | 321 z 322 | ratchet spring | 1 | |
| 52 | — | BZ washer 3,2 DIN 6799 k | 1 | |
| 53 | 131 z 515 | contact bolt | 1 | |
| 54 | 176 z 29 | bushing | 2 | |
| 55 | — | washer 5,3 DIN 125 k | 2 | |
| 56 | — | hex. nut M 5 DIN 934 k | 2 | |
| — | — | hex. screw M 6 x 22 DIN 931 k (for fixing crankcase cover to crankcase) | 8 | |
| — | — | hex. screw M 6 x 25 DIN 931 k (to fasten crankcase cover to crankcase) | 2 | |

Illustration 4, Group M: b) Housing and Cylinder, cylinder and cylinder head

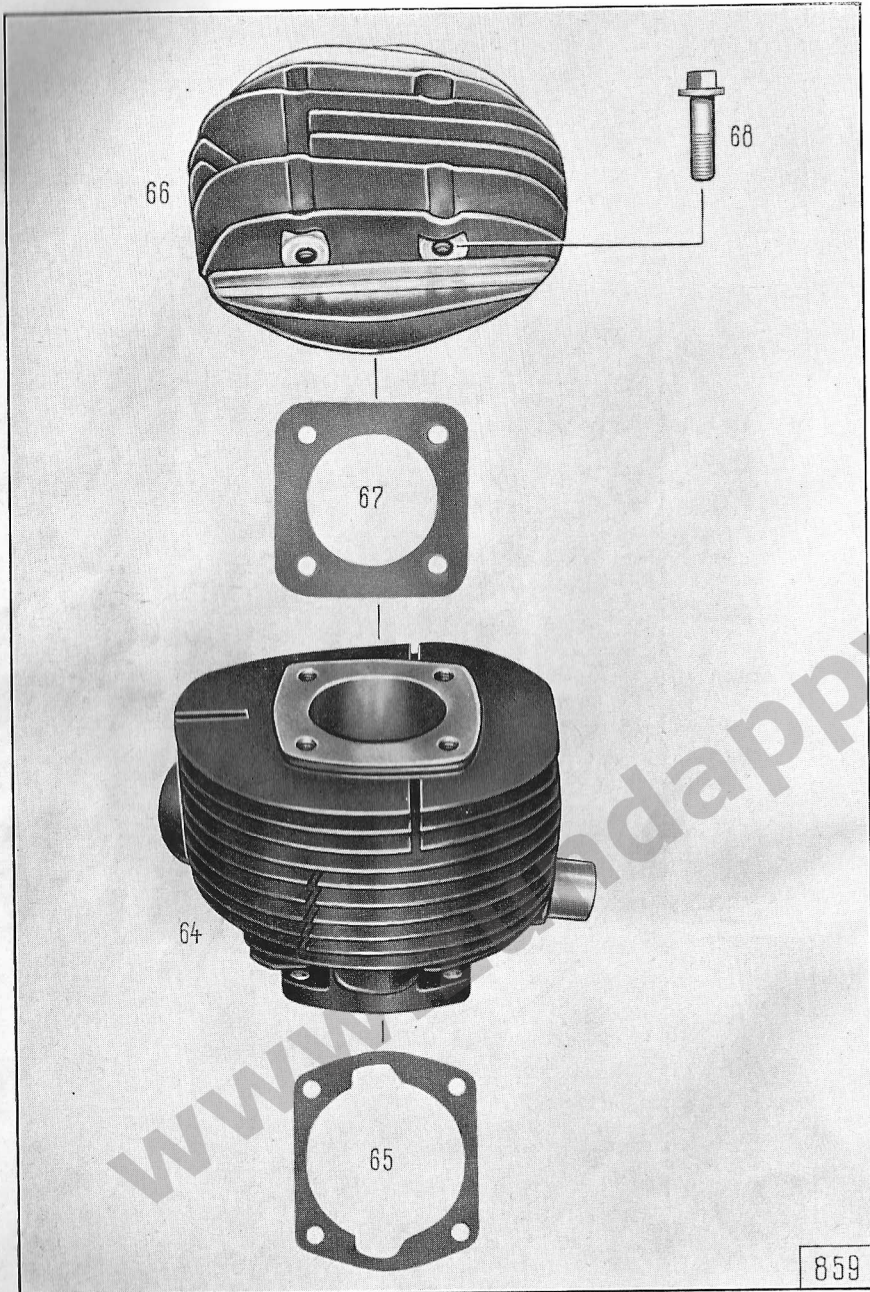

Illustration 4, Group M: b) Housing and Cylinder, cylinder and cylinder head

| Key No. | Spare Part No. | Description | Quantity | Remarks |
|-----------------|----------------|---|----------|----------------------|
| Cylinder | | | | |
| 64 | 2162 z 218 | cylinder | 1 | |
| 65 | 468 z 315 | cylinder base gasket | 1 | |
| 66 | 273 z 167 | cylinder head | 1 | |
| — | 174 z 6 | bushing for spark plug | 1 | for repair work only |
| 67 | 461 z 6 | cylinder head gasket | 1 | |
| 68 | 1551 z 16 | square nut (for fixing cylinder head) | 4 | |

Illustration 5, Group M: c) Drive Mechanism, Crankshaft, Connecting Rod and Piston

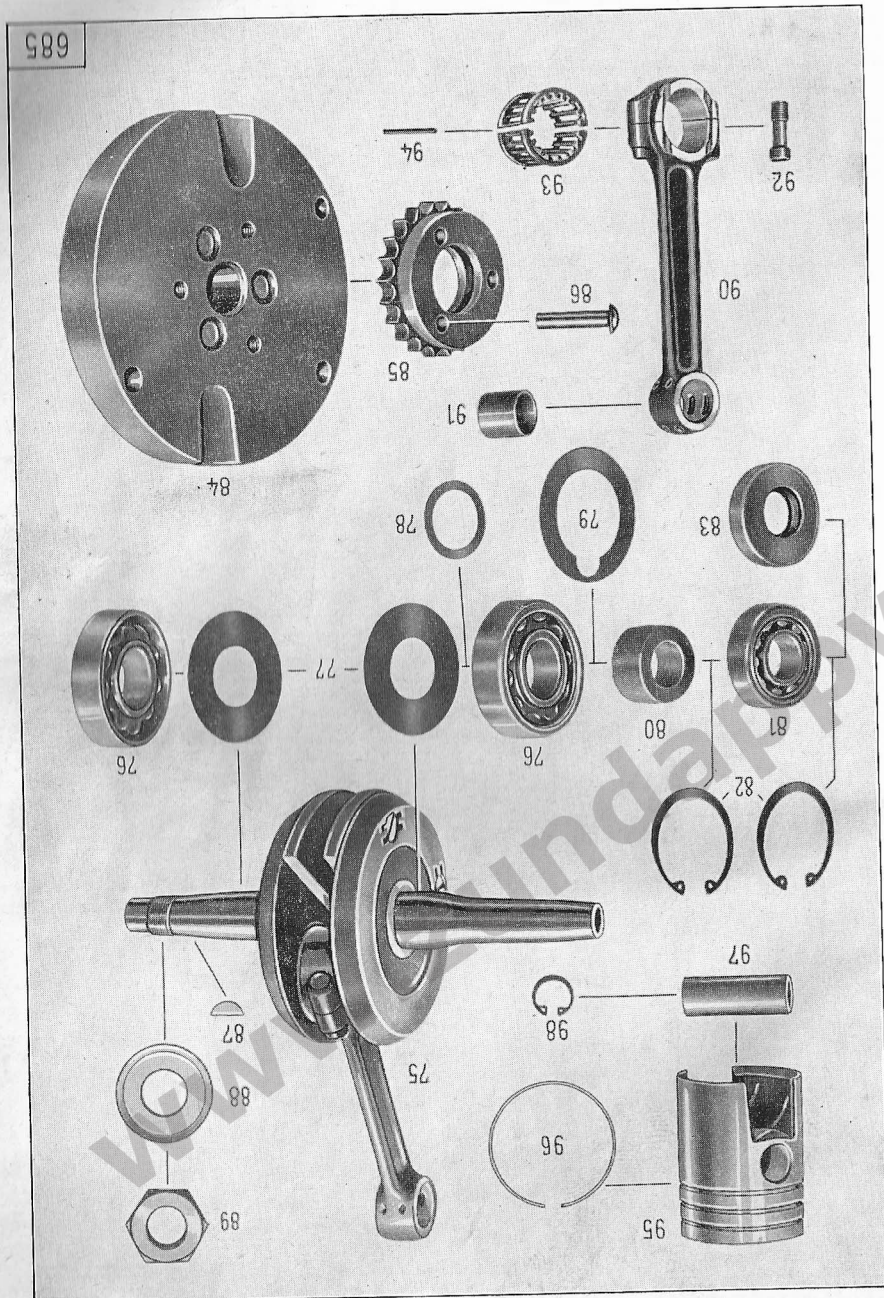

Illustration 5, Group M: c) Drive Mechanism, Crankshaft, Connecting Rod and Piston

| Key No. | Spare Part No. | Description | Quantity | Remarks |
|-----------------------|----------------|--|----------|---|
| Crankshaft | | | | |
| 75 | 1950 k 211 | crankshaft with connecting rod | 1 | } var. } between crankcase and ball bearing |
| 76 | — | ball bearing M 25 DIN 615 | 2 | |
| 77 | 1281 z 382 | covering washer | 2 | |
| 79 | 1301 z 132 | spacer washer 41 x 61,5 x 0,1 | } | |
| — | 1301 z 133 | spacer washer 41 x 61,5 x 0,2 | | |
| — | 1301 z 134 | spacer washer 41 x 61,5 x 0,3 | | |
| — | 1301 z 135 | spacer washer 41 x 61,5 x 0,5 | | |
| — | 1301 z 1012 | spacer washer 41 x 61,5 x 0,15 | | |
| 80 | 181 z 341 | bushing (on crankshaft) | 1 | |
| 81 | — | roller bearing NJL 20 DIN 5412 | 1 | |
| 82 | — | circlip 47 x 1,75 DIN 472 | 2 | |
| 83 | — | radial gasket B 20 x 47 x 10 DIN 6503 | 1 | |
| 84 | 1310 z 60 | flywheel with sprocket | 1 | |
| 85 | 2101 z 155 | sprocket 27 teeth (to flywheel) | 1 | |
| 86 | — | rivet 7 x 40 DIN 660 | 3 | |
| 87 | — | key 4 x 6,5 DIN 6888 | 1 | |
| 88 | 1291 z 64 | lock washer | 1 | |
| 89 | 1001 z 20 | hex. nut | 1 | |
| Connecting Rod | | | | |
| 90 | 1160 k 151 | connecting rod | 1 | |
| 91 | 184 z 523 | piston pin bushing | 1 | |
| 92 | 1571 z 1 | connecting rod screw | 2 | |
| 93 | 1874 z 1 | cage ring | 1 | |
| 94 | 1871 z 1 | bearing needle | 18 | |
| Piston | | | | |
| 95 | 883 z 169 | piston 64,0 ϕ (standart) | 1 | |
| — | 2473 k 91-0 | piston 64,5 ϕ | 1 | |
| — | 2473 k 92-0 | piston 65,0 ϕ | 1 | |
| — | 2473 k 93-0 | piston 65,5 ϕ | 1 | |
| — | 2473 k 94-0 | piston 66,0 ϕ | 1 | |
| 96 | 1262 z 107 | piston ring 64,0 ϕ (standart) | 3 | |
| — | 2442 k 58-0 | piston ring 64,5 ϕ | 3 | |
| — | 2442 k 59-0 | piston ring 65,0 ϕ | 3 | |
| — | 2442 k 60-0 | piston ring 65,5 ϕ | 3 | |
| — | 2442 k 61-0 | piston ring 66,0 ϕ | 3 | |
| 97 | 121 z 1066 | piston pin | 1 | |
| 98 | — | circlip 18 x 1 DIN 472 | 2 | |

Illustration 6, Group M: f) Carburettor

| Key No. | Spare Part No. | Description | Quantity | Remarks |
|---------|----------------|---|----------|---------|
| 122 | 2404 k 23-0 | jet (idle jet, size 40) | 1 | |
| 123 | 2401 k 51-6 | lock screw | 1 | |
| 124 | 2407 k 6-0 | seal ring (to lock screw) | 1 | |
| 125 | 2403 k 110-0 | start piston | 1 | |
| 126 | 2403 k 111-0 | sleeve (start piston) | 1 | |
| 127 | 2401 k 90-2 | thrust spring | 1 | |
| 128 | 2404 k 23-0 | jet (starter jet) size 70 | 1 | |
| 129 | 2401 k 51-6 | lock screw | 1 | |
| 130 | 2407 k 6-0 | seal ring (to lock screw) | 1 | |
| 131 | 2401 k 91-0 | lock screw | 1 | |
| 112 | 2401 k 5-4 | adjusting screw for throttle cable | | |
| 113 | 2401 k 6-2 | nut (to adjusting screw for throttle cable) | 1 | |
| 134 | 2403 k 115-0 | floater chamber | 1 | |
| 135 | 2404 k 31-0 | floater | 1 | |
| 136 | 2401 k 93-0 | floater needle | 1 | |
| 137 | 2403 k 100-0 | floater chamber cover | 1 | |
| 138 | 2401 k 61-2 | fixing screw (to cover) | 2 | |
| 139 | 2401 k 94-0 | lock screw | 1 | |
| 140 | 2407 k 18-0 | seal ring (to lock screw) | 1 | |

www.zundappvetzclub.nl

Illustration 7, Group M: f) Carburettor Intake Silencer

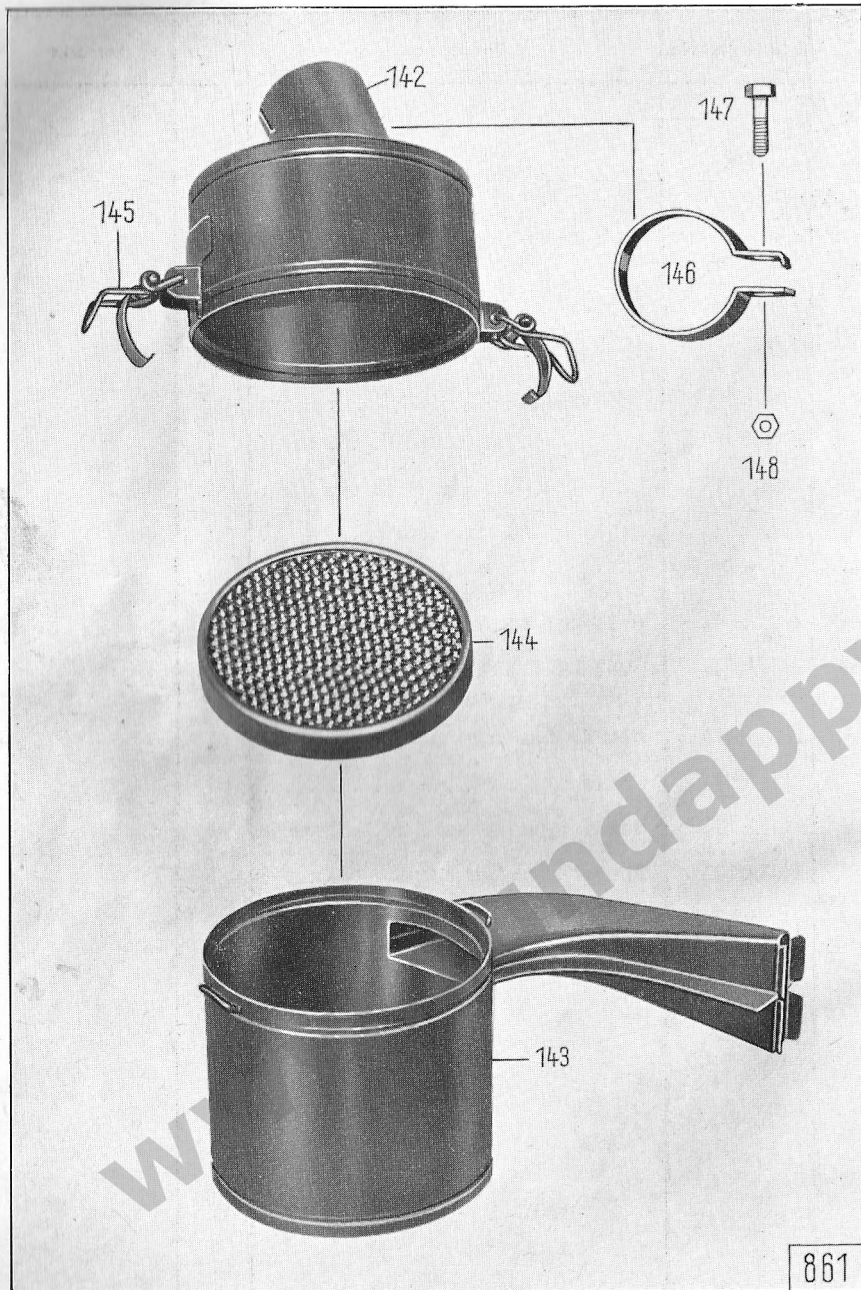

Illustration 7, Group M: f) Carburettor Intake Silencer

| Key No. | Spare Part No. | Description | Quantity | Remarks |
|------------------------|----------------|---|----------|---------|
| Intake Silencer | | | | |
| 142 | 6410 z 216 | intake silencer, front part | 1 | |
| 143 | 6410 z 217 | intake silencer, rear part | 1 | |
| 144 | 780 z 102 | air cleaner inset | 1 | |
| 145 | 1860 z 12 | clamping device | 2 | |
| 146 | 1441 z 160 | clamp | 1 | |
| 147 | — | hex. head screw M 6 x 25 DIN 931 z | 1 | |
| 148 | — | hex. nut M 6 DIN 934 z | 1 | |

861

Illustration 8, Group M: g) Clutch, clutch, operating mechanism

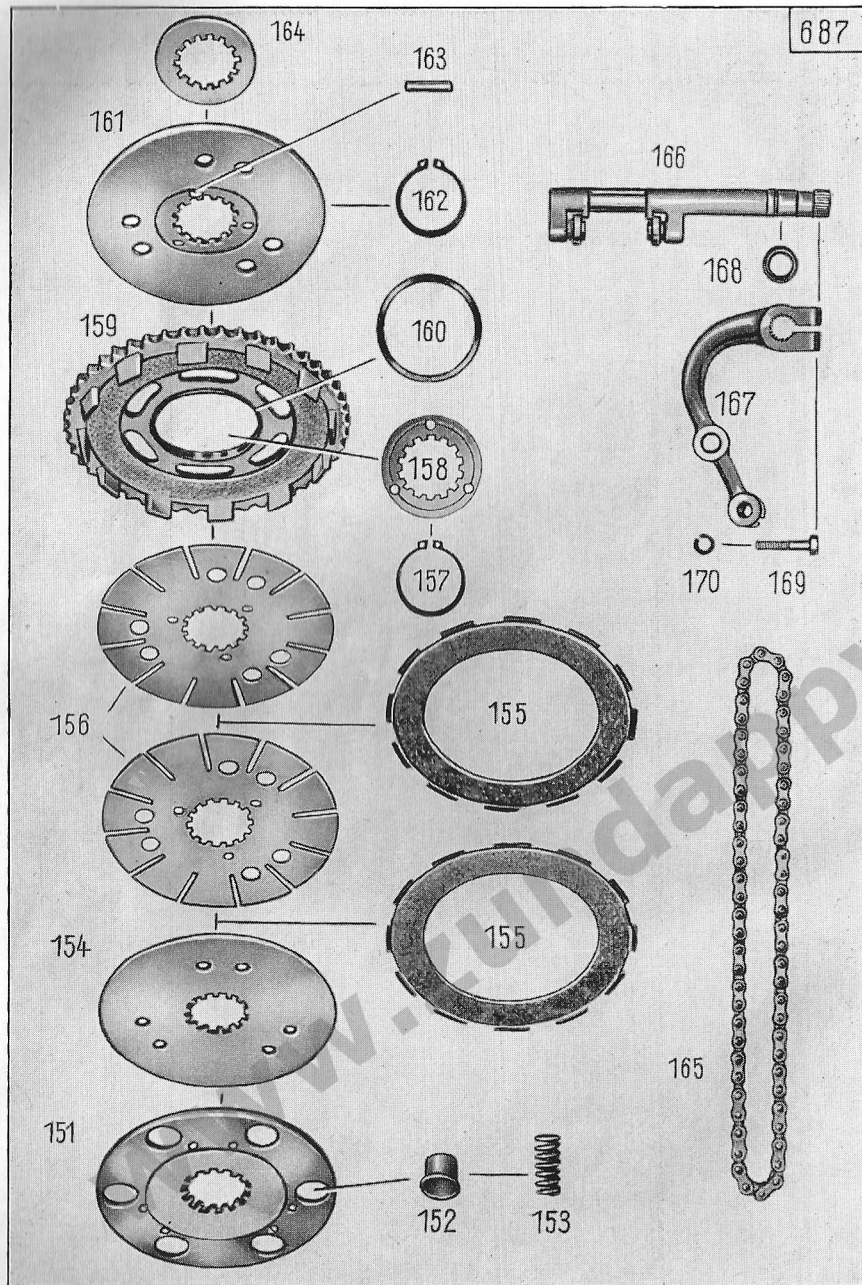

Illustration 8, Group M: g) Clutch, clutch, operating mechanism

| Key No. | Spare Part No. | Description | Quantity | Remarks |
|-----------------------------------|----------------|--|----------|---------------------------|
| Clutch | | | | |
| 151 | 921 z 69 | spring plate | 1 | |
| 152 | 781 z 273 | spring cap (for spring plate) | 6 | |
| 153 | 321 z 564 | clutch spring (length 31,9; outer- ϕ 13,8, wire- ϕ 1,8) | 6 | |
| — | 321 z 536 | clutch spring (length 29,1, outer- ϕ 14,1, wire- ϕ 2,1) | 6 | |
| 154 | 921 z 67 | clutch pressure plate | 1 | |
| 155 | 920 z 52 | clutch disc with lining | 2 | |
| 156 | 921 z 68 | clutch disc | 2 | with ground side surfaces |
| 157 | — | circlip 35 x 1,5 DIN 471 | 1 | |
| 158 | 1231 z 212 | intermediate ring | 1 | |
| 159 | 2100 z 165 | clutch sprocket with bushing 48 teeth | 1 | |
| 160 | 184 z 317 | bushing (for clutch sprocket) | 1 | |
| 161 | 921 z 203 | clutch plate | 1 | |
| 162 | — | circlip 35 x 1,5 DIN 471 | 1 | with ground side surfaces |
| 163 | 1691 z 113 | pressure pin | 3 | |
| 164 | 1231 z 213 | pressure ring | 1 | |
| 165 | — | roller chain with 64 links, endless, A 9,5 x 9,5 DIN 73232 | 1 | |
| Clutch Operating mechanism | | | | |
| 166 | 1940 z 25 | clutch pressure bar, complete | 1 | |
| 167 | 671 z 338 | clutch lever (for clutch pressure bar) | 1 | |
| 168 | 1236 z 222 | seal ring | 1 | |
| 169 | — | hex. head screw M 6 x 25 DIN 931 k (to fix clutch lever to clutch pressure bar) | 1 | |
| 170 | — | spring washer A 6 DIN 127 k | 1 | |

Illustration 9, Group G: c) Shafts and Gears, gear selector shaft layshaft

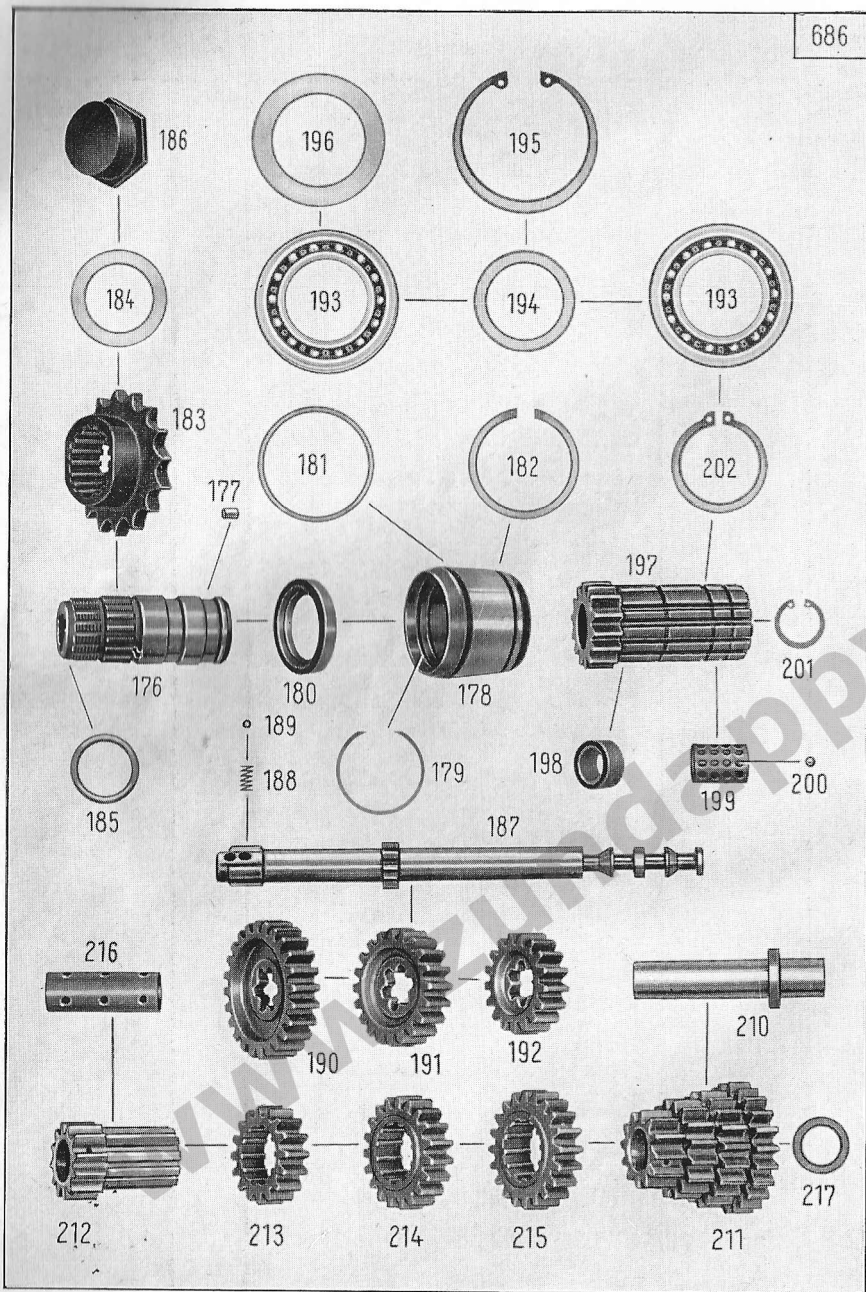

Illustration 9, Group G: c) Shafts and Gears, gear selector shaft, layshaft

| Key No. | Spare Part No. | Description | Quantity | Remarks |
|----------------------------|----------------|---|----------|--|
| Gear Selector Shaft | | | | |
| 176 | 961 z 125 | final drive shaft | 1 | |
| 177 | 1871 z 07 | roller | 38 | |
| 178 | 1871 z 154 | bearing ring (to left half of crankcase) | 1 | |
| 179 | 1251 z 99 | internal lock ring | 2 | } as required |
| — | 1251 z 251 | internal lock ring | 2 | |
| — | 1251 z 252 | internal lock ring | 2 | |
| 180 | — | radial gasket B 32 x 45 x 7 DIN 6503 (in the bearing ring) | 1 | |
| 181 | 1301 z 603 | compensating washer 48,1x52,3x0,5 | } var. | } between bearing ring and half of crankcase |
| — | 1301 z 604 | compensating washer 48,1x52,3x0,3 | | |
| — | 1301 z 605 | compensating washer 48,1x52,3x0,2 | | |
| 182 | 1251 z 176 | lock ring (to fasten bearing ring to half of the crankcase) | 1 | |
| 183 | 2101 z 60 | chain sprocket with 16 teeth (on final drive shaft) | 1 | |
| 184 | 1291 z 65 | lock washer | 1 | |
| 185 | 1236 z 220 | seal ring | 1 | |
| 186 | 1001 z 214 | lock nut (to fasten chain sprocket to final drive shaft) | 1 | |
| 187 | 1921 z 701 | gear selector shaft | 1 | |
| 188 | 321 z 312 | thrust spring | 2 | |
| 189 | — | steel ball 6 mm III DIN 5401 | 3 | |
| 190 | 2131 z 303 | pinion 1st speed 24 teeth | 1 | |
| 191 | 2131 z 304 | pinion 2nd speed 20 teeth | 1 | |
| 192 | 2131 z 307 | pinion 3rd speed 17 teeth | 1 | |

Illustration 9, Group G: c) Shafts and Gears, gear selector shaft, layshaft

| Key No. | Spare Part No. | Description | Quantity | Remarks |
|-----------------|----------------|--|----------|---|
| 193 | — | ball bearing 16007 DIN 625 (to right half of the crankcase) . . . | 2 | } as required |
| 194 | — | spacer ring 35 x 45 x 2 DIN 988 (between the ball bearings) . . . | 1 | |
| — | 1301 k 1093 | spacer ring | 1 | |
| 195 | — | circlip 62 x 2 DIN 472 | 1 | |
| 196 | 1301 z 133 | covering disc (between crankcase and ball bearing) | 1 | |
| 197 | 960 z 101 | clutch hub (simultaneously 4th speed) | 1 | |
| 198 | 184 z 324 | bearing bush (to clutch hub) | 1 | |
| 199 | 1871 z 151 | ball cage | 1 | |
| 200 | — | steel ball 4 mm III DIN 5401 | 40 | |
| 201 | 1251 k 259 | circlip J 23 x 1,2 | 1 | |
| 202 | — | circlip 35 x 1,5 DIN 471 (to fasten the clutch hub to the half of the crankcase) | 1 | with ground side surfaces |
| Layshaft | | | | |
| 210 | 1940 z 206 | layshaft | 1 | |
| 211 | 2130 z 101 | pinion block, complete | 1 | |
| 212 | 2131 z 238 | pinon 1st speed 12 teeth | 1 | |
| 213 | 2131 z 239 | pinion 2nd speed 16 teeth | 1 | |
| 214 | 2131 z 247 | pinion 3rd speed 19 teeth | 1 | |
| 215 | 2131 z 237 | drive pinion 22 teeth | 1 | |
| 216 | 184 z 316 | bushing | 1 | |
| 217 | 1301 z 177 | compensating washer 18,2x25,7x0,5 | var. | } between pinion block & right half of crankcase |
| — | 1301 z 367 | compensating washer 18,2x25,7x0,2 | var. | |
| — | 1301 z 368 | compensating washer 18,2x25,7x0,3 | var. | |

Illustration 10, Group G: d) Footshift Operating Mechanism

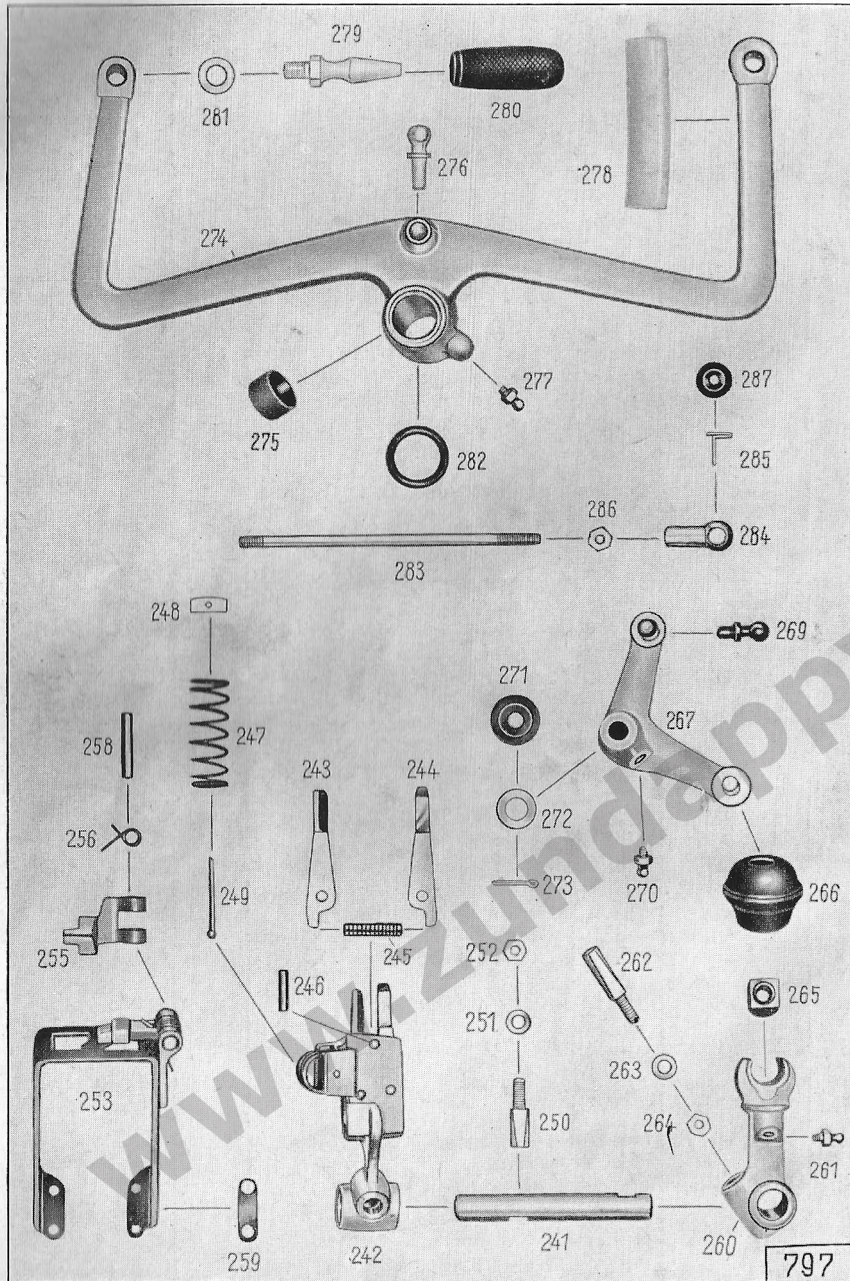

Illustration 10, Group G: d) Footshift Operating Mechanism

| Key No. | Spare Part No. | Description | Quantity | Remarks |
|--------------------------------------|----------------|---|----------|---------------|
| Footshift Operating Mechanism | | | | |
| 241 | 1941 z 312 | footshift shaft (for selector fork) . . . | 1 | |
| 242 | 670 k 233 | gear selector fork, complete | 1 | |
| 243 | 841 z 40 | selector finger, left-hand | 1 | |
| 244 | 841 z 41 | selector finger, right-hand | 1 | |
| 245 | 321 z 317 | thrust spring | 1 | |
| 246 | — | riveting pin A 5 h 9 x 20 DIN 7341 | 3 | |
| 247 | 321 z 316 | return working spring | 1 | |
| 248 | 1281 z 359 | joint | 2 | |
| 249 | — | split pin 3 x 35 DIN 94 | 1 | |
| 250 | 121 z 1112 | cotter pin (to fasten selector fork to footshift shaft) | 1 | |
| 251 | — | lock washer B 6 DIN 137 k | 1 | |
| 252 | — | hex. nut M 6 DIN 934 k | 1 | |
| 253 | 200 z 107 | gear selector fork guide with ratchet | 1 | |
| 254 | 841 z 39 | ratchet | 1 | |
| 255 | 321 z 322 | ratchet spring | 1 | |
| 256 | — | riveting pin A 6 h 9 x 32 DIN 7341 (to fix ratchet to gear selector fork guide) | 1 | |
| 257 | 1281 z 242 | washer | 4 | } as required |
| — | 1281 z 243 | washer | 4 | |
| — | 1281 z 244 | washer | 4 | |
| — | 1281 z 414 | washer | 4 | |
| 260 | 671 z 315 | gearshift lever | 1 | |
| 261 | — | grease nipple D 6 DIN 71412 | 1 | |

Illustration 10, Group G: d) Footshift Operating Mechanism

| Key No. | Spare Part No. | Description | Quantity | Remarks |
|---------|----------------|--|----------|---------|
| 262 | 121 z 553 | cotter pin (to fasten shift lever to selector shaft) | 1 | |
| 263 | — | lock washer B 6 DIN 137 k | 2 | |
| 264 | — | hex. nut M 6 DIN 934 k | 1 | |
| 265 | 574 z 6 | slide block (to shift lever) | 1 | |
| 266 | 616 z 215 | rubber sleeve (to shift lever) | 1 | |
| 267 | 670 z 214 | angle lever | 1 | |
| 269 | — | ball pivot B 10 x 8 DIN 803 | 1 | |
| 270 | — | grease nipple D 6 DIN 71412 | 1 | |
| 271 | 1236 z 310 | rubber ring | 2 | |
| 272 | — | washer 10,5 DIN 125 k | 1 | |
| 273 | — | split pin 3 x 18 DIN 94 k | 1 | |
| 274 | 680 z 35 | footshift lever | 1 | |
| 275 | 184 z 516 | bushing (to footshift lever) | 2 | |
| 276 | 131 z 523 | ball pivot | 1 | |
| 277 | — | grease nipple D 6 DIN 71412 | 1 | |
| 278 | 1596 z 294 | hose | 2 | |
| 279 | 121 z 1039 | bolt | 2 | |
| 280 | 616 z 231 | rubber sleeve | 2 | |
| 281 | — | lock washer A 10 DIN 137 k | 2 | |
| 282 | 1236 z 315 | seal ring | 2 | |
| 283 | 1651 z 344 | gearshift rod | 1 | |
| 284 | — | ball socket B 10 DIN 71805 z | 2 | |
| 285 | — | lock bracket S 10 DIN 71805 z | 2 | |
| 286 | — | hex. nut M 6 DIN 934 z | 1 | |
| 287 | 616 z 11 | rubber sleeve | 2 | |

Illustration 11, Group R: a) Frame

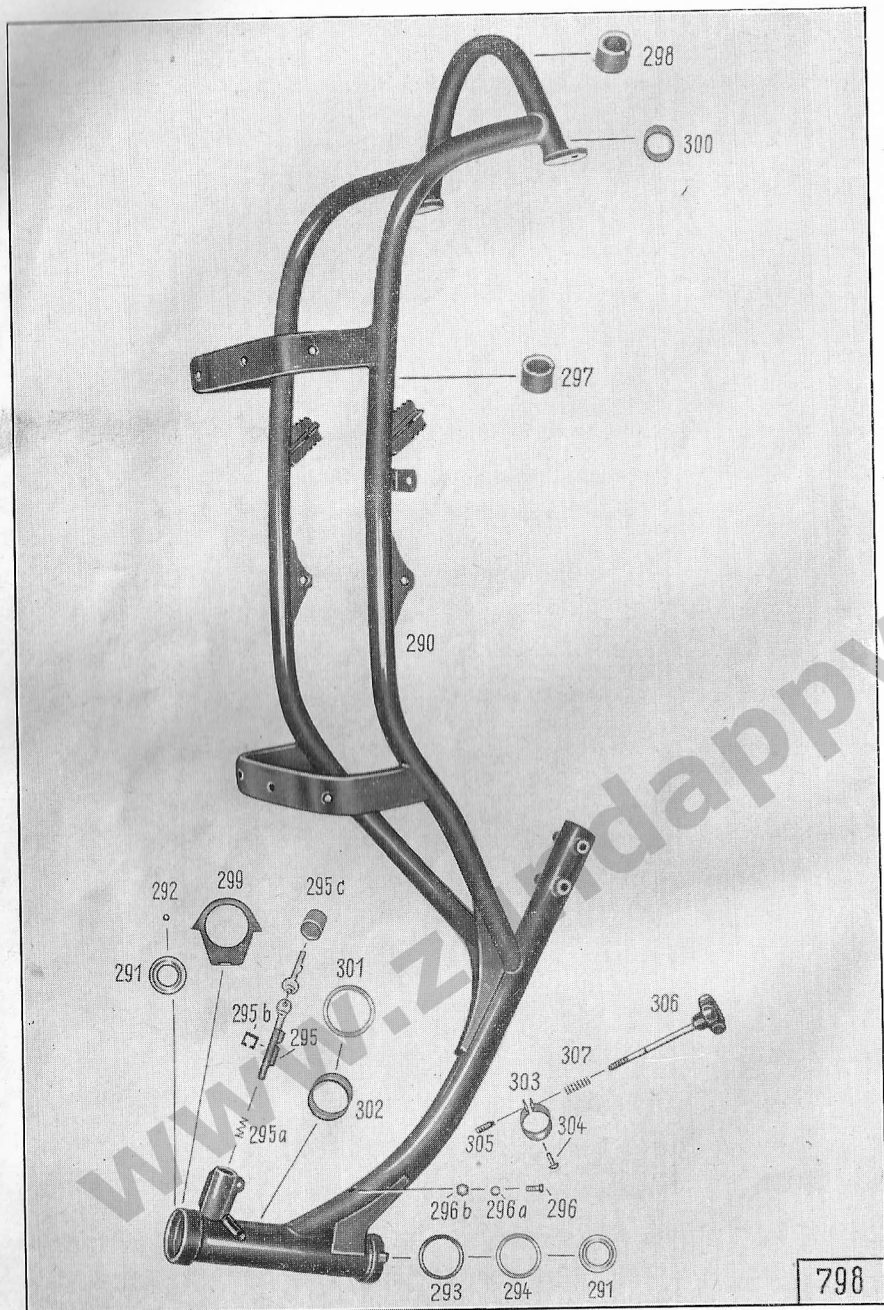

Illustration 11, Group R: a) Frame

| Key No. | Spare Part No. | Description | Quantity | Remarks |
|--------------|----------------|--|----------|---------|
| Frame | | | | |
| 290 | 6690 z 339 | frame | 1 | |
| 291 | 1871 z 171 | frame race | 2 | |
| 292 | — | steel ball 6,35 mm DIN 5401 | 38 | |
| 293 | 1231 z 210 | covering ring | 1 | |
| 294 | 1236 z 333 | seal ring | 1 | |
| 295 | 6040 z 274 | antitheft lock | 1 | |
| 295a | 321 z 537 | spring (to antitheft lock) | 1 | |
| 295b | 211 z 250 | clip (to fix antitheft lock) | 1 | |
| 295c | 1236 z 338 | ring (to bushing of antitheft lock) | 1 | |
| 296 | — | hex. head bolt M 6 x 10 DIN 933 k (to fasten earth cable to frame) | 1 | |
| 296a | — | lock washer B 6 DIN 137 | 1 | |
| 296b | — | hex. nut M 6 DIN 934 k | 1 | |
| 297 | 616 z 234 | rubber sleeve (for fixing fuel tank) | 4 | |
| 298 | 616 z 234 | rubber sleeve (to rear frame elbow) | 1 | |
| 299 | 1236 z 316 | rubber ring (between steering tube and casing) | 1 | |
| 300 | 1236 z 334 | rubber ring | 2 | |
| 301 | 1236 z 323 | rubber ring (for fixing of cables) | 1 | |
| 302 | 1236 z 355 | rubber ring (to fasten cables) | 1 | |
| 303 | 1234 z 15 | spanner ring (for steering damper) | 1 | |
| 304 | — | pin 3 x 8 DIN 1476 k | 1 | |
| 305 | — | threaded pin M 8 x 15 DIN 417 k | 1 | |
| 306 | 590 z 102 | handle with bolt | 1 | |
| — | 1291 z 106 | Seeger lock ring | 1 | |
| — | — | washer 8,4 DIN 433 | 1 | |
| 307 | 321 z 23 | spring | 1 | |

Illustration 12, Group R: a) Frame, front engine carrier and center stand

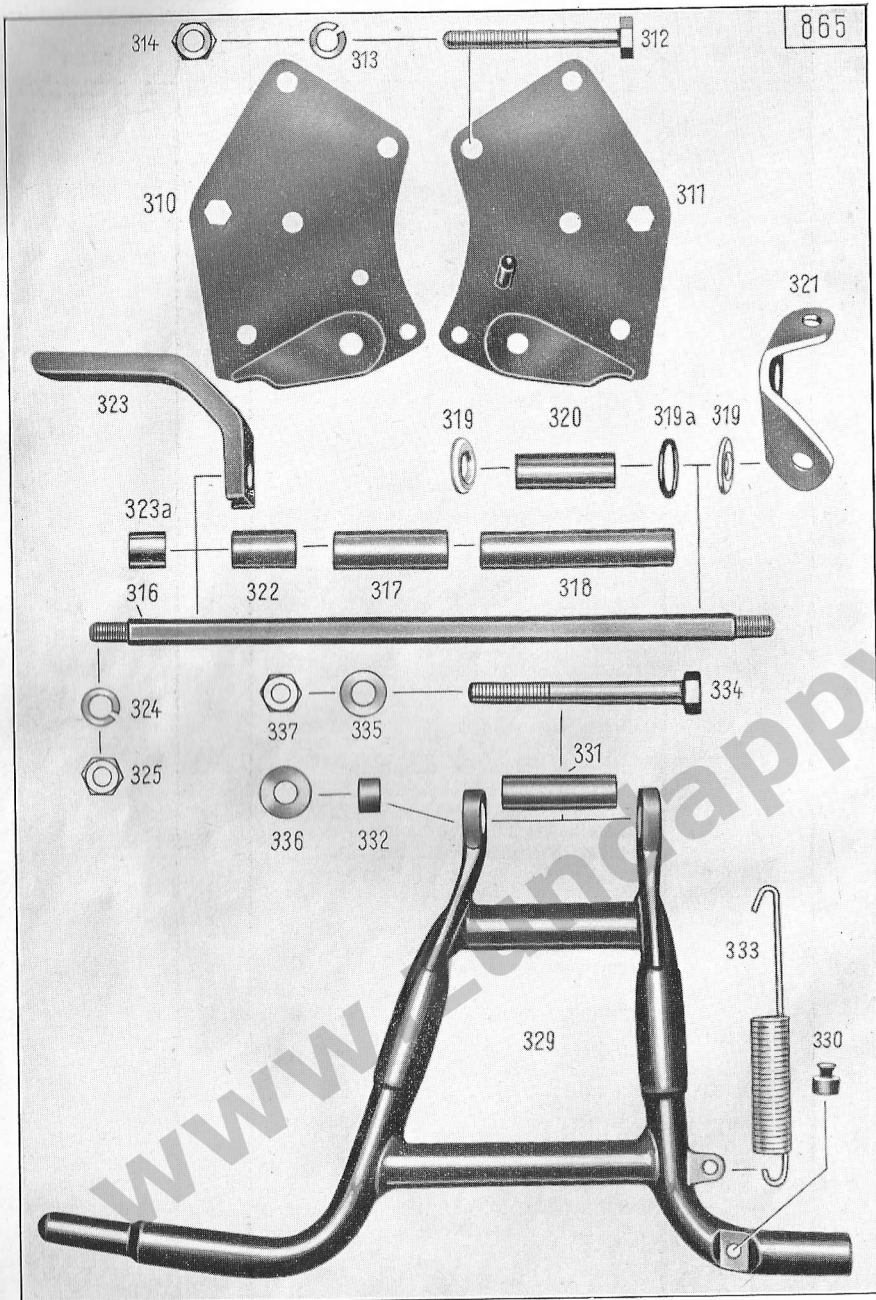

Illustration 12, Group R: a) Frame, front engine carrier and center stand

| Key No. | Spare Part No. | Description | Quantity | Remarks |
|-----------------------------|----------------|---|----------|---------|
| Front Engine Carrier | | | | |
| 310 | 1180 z 369 | engine suspension plate, left | 1 | |
| 311 | 1180 z 370 | engine suspension plate, right | 1 | |
| 312 | — | hex. head bolt M 10 x 80 DIN 931 k (to fasten engine suspension plates to frame) | 2 | |
| 313 | — | lock ring A 10 DIN 127 k | 2 | |
| 314 | — | hex. nut M 10 DIN 934 k | 2 | |
| 316 | 121 z 1099 | front bearing bolt | 1 | |
| 317 | 1331 z 778 | spacer tube (between engine suspension plates) | 1 | |
| 318 | 1331 z 842 | spacer tube, right | 1 | |
| 319 | 1301 z 656 | intermediate disc | 2 | |
| 319a | 1236 z 315 | seal ring | 2 | |
| 320 | 1331 z 767 | spacer tube (for footshift lever) | 1 | |
| 321 | 631 z 585 | front foot board support, right | 1 | |
| 322 | 1331 z 1005 | spacer tube, left | 1 | |
| — | 1301 z 1135 | washer | var. | |
| 323 | 630 z 503 | front foot board support, left | 1 | |
| 323a | 1331 z 905 | spacer tube, left | 1 | |
| 324 | — | lock ring A 12 DIN 127 k | 2 | |
| 325 | — | hex. nut M 12 DIN 934 k (on bearing bolt) | 2 | |
| Center Stand | | | | |
| 329 | 1750 z 263 | center stand | 1 | |
| 330 | 1126 z 1 | rubber damper | 1 | |
| 331 | 1331 z 781 | spacer tube (between engine suspension plates) | 1 | |
| 332 | 1331 z 891 | spacer tube (to hex. nut) | 2 | |
| 333 | 321 z 588 | pull spring | 1 | |
| 334 | — | hex. head bolt M 12 x 110 DIN 931 a (to fasten center stand to front engine carrier) | 1 | |
| 335 | — | spring washer B 12 DIN 137 k | 1 | |
| 336 | 1301 z 01 | spacer shim 12,3 x 26 x 0,5 | var. | |
| — | 1301 z 669 | spacer shim 12,3 x 26 x 0,2 | var. | |
| — | 1301 z 670 | spacer shim 12,3 x 26 x 0,3 | var. | |
| — | 1301 z 1042 | washer | var. | |
| 337 | — | hex. nut M 12 DIN 934 a | 1 | |

Illustration 13, Group R: a) Frame, rear engine carrier with swinging fork

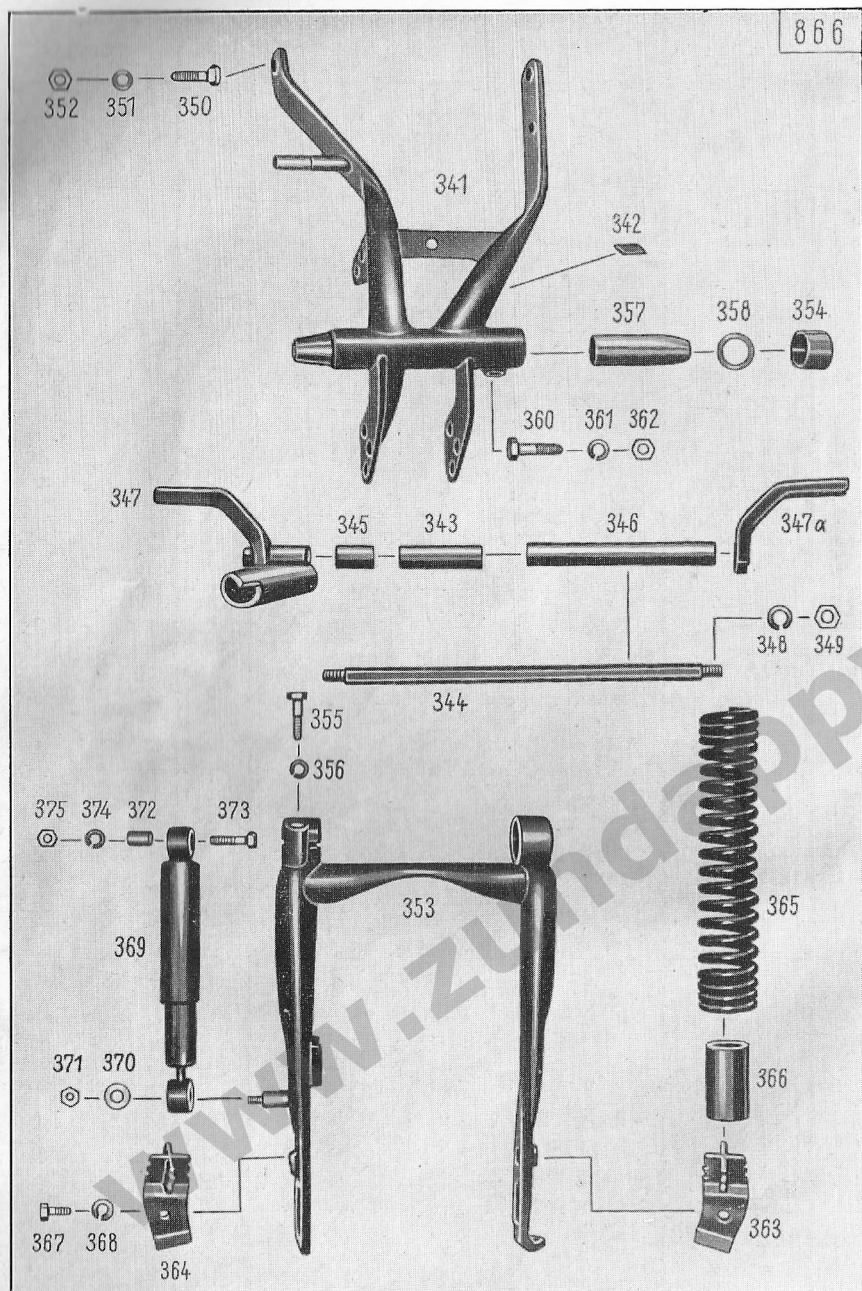

Illustration 13, Group R: a) Frame, rear engine carrier with swinging fork

| Key No. | Spare Part No. | Description | Quantity | Remarks |
|----------------------------|----------------|---|----------|---------|
| Rear Engine Carrier | | | | |
| 341 | 630 z 569 | rear engine carrier | 1 | |
| 342 | 616 z 224 | plug | 1 | |
| 343 | 1331 z 773 | spacer tube (between engine suspension plates) | 1 | |
| 344 | 121 z 1171 | rear bearing bolt | 1 | |
| 345 | 1331 z 1000 | spacer tube (rear left side) | 1 | |
| — | 1301 z 1135 | washer | var. | |
| 346 | 1331 z 999 | spacer tube (rear right side) | 1 | |
| 347 | 630 z 568 | foot board carrier, rear left) | 1 | |
| 347a | 630 z 567 | foot board carrier, rear right) | 1 | |
| 348 | — | lock ring A 12 DIN 127 k | 2 | |
| 349 | — | hex. nut M 12 DIN 934 k (on bearing bolt) | 2 | |
| 350 | — | hex. head bolt M 10 x 35 DIN 931 a (to fasten rear engine carrier to frame) | 2 | |
| 351 | — | lock washer B 10 DIN 137 k | 2 | |
| 352 | — | hex. nut M 10 DIN 934 k | 2 | |
| Swinging fork | | | | |
| 353 | 710 z 250 | rear swinging fork | 1 | |
| 354 | 184 z 517 | bushing for swinging fork | 2 | |
| 355 | — | hex. head bolt M 8 x 30 DIN 931 k (to fasten bushing to swinging fork) | 2 | |
| 356 | — | lock ring a 8 DIN 127 | 2 | |
| 357 | 121 z 1084 | bearing bolt, right side | 1 | |
| — | — | hex. head bolt M 6 x 6 DIN 933 k | 1 | |

Illustration 13, Group R: a) Frame, rear engine carrier with swinging fork

| Key No. | Spare Part No. | Description | Quantity | Remarks |
|---------|----------------|---|----------|---------|
| — | — | lock washer B 6 DIN 137 k | 1 | |
| 358 | 1236 z 320 | rubber ring | } | } var. |
| — | 1236 z 321 | rubber ring | | |
| — | 1236 z 322 | rubber ring | | |
| 360 | — | hex. head bolt M 10 x 40 DIN 931 k (to fasten bearing bolt to engine carrier) | 1 | |
| 361 | — | lock ring A 10 DIN 127 k | 1 | |
| 362 | — | hex. nut M 10 DIN 934 k | 1 | |
| 363 | 630 z 494 | lower spring carrier, right side . . | 1 | |
| 364 | 630 z 493 | lower spring carrier, left side . . | 1 | |
| 365 | 321 z 569 | thrust-pull spring | 2 | |
| 366 | 616 z 246 | rubber sleeve | 2 | |
| 367 | — | hex. head bolt M 10 x 18 DIN 933 k (to fasten spring carrier to swinging arm) | 2 | |
| 368 | — | lock ring A 10 DIN 127 k | 2 | |
| 369 | 6350 z 101 | shock absorber | 1 | ← |
| — | 2376 k 2 | rubber sleeve | 4 | |
| 370 | 1301 z 168 | washer | 1 | |
| 371 | — | hex. nut M 8 DIN 934 k | 1 | |
| 372 | 1331 z 885 | spacer tube | 1 | |
| 373 | — | hex. head bolt M 8 x 35 DIN 931 k (to fasten shock absorber to frame) | 1 | |
| 374 | — | lock ring A 8 DIN 127 k | 1 | |
| 375 | — | hex. nut M 8 DIN 934 k | 1 | |

www.zundappveteraanclub.nl

Illustration 14, Group R: b) Foot Boards, Folding Grids and Side Stand

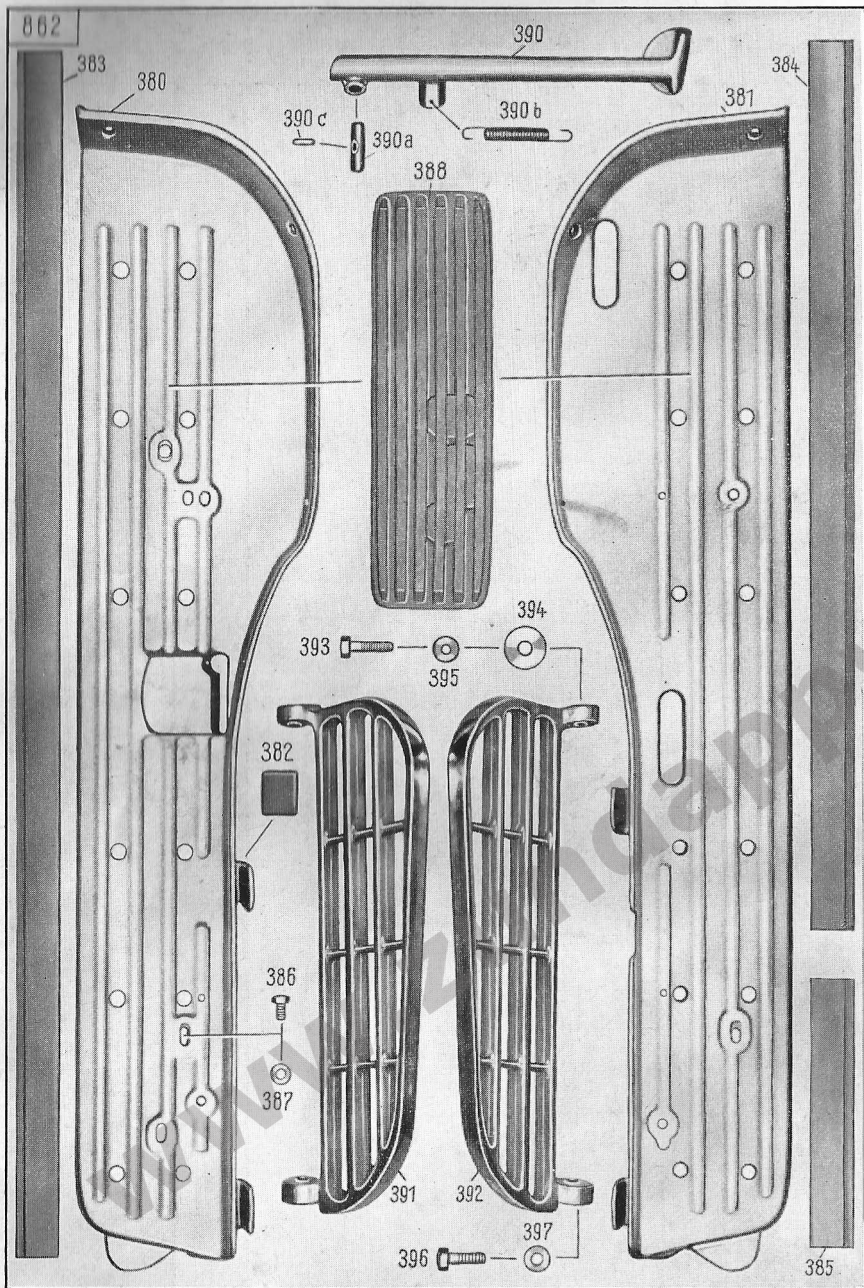
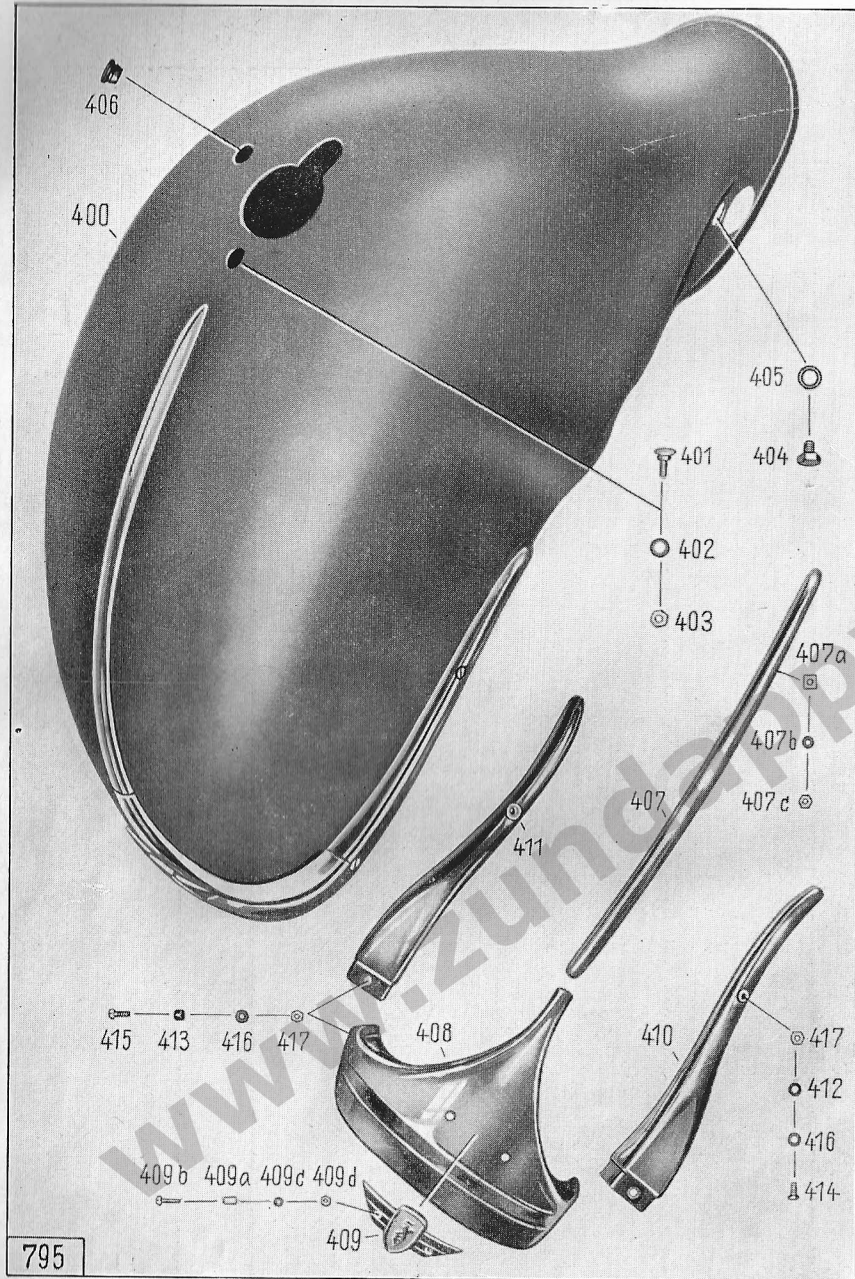

Illustration 14, Group R: b) Foot Boards, Folding Grids and Side Stand

| Key No. | Spare Part No. | Description | Quantity | Remarks |
|----------------------|----------------|--|----------|---|
| Foot Boards | | | | |
| 380 | 470 z 51 | foot board, left side | 1 | |
| 381 | 470 z 52 | foot board, right side | 1 | |
| 382 | 1596 z 404 | rubber hose | 2 | } foot board left |
| 383 | 1397 z 24 | beading | 1 | |
| 382 | 1596 z 404 | rubber hose | 2 | } foot board right |
| 384 | 1397 z 25 | front beading | 1 | |
| 385 | 1397 z 26 | rear beading | 1 | |
| 386 | — | hex. head bolt M 6 x 12 DIN 933 k (to fasten foot board to foot board carrier) . . | 4 | |
| 387 | — | lock washer B 6 DIN 137 k | 4 | |
| 388 | 1146 z 105 | rubber foot mat | 4 | |
| Side Stand | | | | |
| 390 | 1750 z 261-8 | side stand | 1 | |
| 390a | 121 z 1172 | bolt (to fix foot board left) | 1 | |
| 390b | 321 z 633 | pull spring | 1 | |
| 390c | — | grooved pin 3 x 12 DIN 1476z | 1 | |
| Folding Grids | | | | |
| 391 | 653 z 139 | folding grid, left side | 1 | |
| 392 | 653 z 140 | folding grid, right side | 1 | |
| 393 | — | hex. head bolt M 8 x 30 DIN 931 k (to fasten folding grids to foot board) | 2 | |
| 394 | 1303 z 103 | compensating washer 8,4 x 30 x 0,5 | var. | } between folding grids and foot boards |
| — | 1303 z 104 | compensating washer 8,4 x 30 x 1 | var. | |
| — | 1301 z 674 | compensating washer 8,4 x 28 x 2,0 | var. | |
| — | — | washer A 8,4 DIN 9021 k | 2 | |
| 395 | — | lock washer B 8 DIN 137 k | 2 | |
| 396 | — | hex. head bolt M 8 x 25 DIN 931 k (to fasten folding grids to frame) | 2 | |
| 397 | — | lock washer B 8 DIN 137 k | 2 | |

Illustration 15, Group R: d) Mudguards, front mudguard



795

Illustration 15, Group R: d) Mudguards, front mudguard

| Key No. | Spare Part No. | Description | Quantity | Remarks |
|-----------------------|----------------|---|----------|---------------------|
| Front Mudguard | | | | |
| 400 | 6370 z 184 | front mudguard | 1 | Indicate colour |
| 401 | — | screw M 6 x 15 DIN 603 k (to fasten front mudguard to swinging arm) | 1 | |
| 402 | — | lock ring A 6 DIN 127 k | 1 | |
| 403 | — | hex. nut M 6 DIN 934 k | 1 | |
| 404 | — | hex. head bolt M 8 x 10 DIN 933 crp (to fasten front mudguard to swinging fork) | 2 | |
| 405 | — | spring washer A 8 DIN 137 k | 2 | |
| 406 | 616 z 216 | sleeve (to front brake cable) | 1 | |
| 407 | 943 z 33 | fancy strip | 1 | |
| 407a | 1551 z 443 | screw to fancy strip | 3 | |
| 407b | — | spring washer A 4 DIN 137 k | 3 | |
| 407c | — | hex. nut M 4 DIN 934 k | 3 | |
| 408 | 1141 z 2277 | front decorative plate | 1 | |
| 409 | 1483 z 69 | ZUNDAPP emblem | 1 | |
| 409a | 1241 z 122 | spacer piece | 2 | |
| 409b | — | raised head screw AM 3 x 15 DIN 91 | 2 | elox. light gold |
| 409c | — | lock washer A 3 DIN 137 k | 2 | |
| 409d | — | hex. nut M 3 DIN 934 k | 2 | |
| 410 | 1141 z 2278 | decorative plate, left side | 1 | |
| 411 | 1141 z 2279 | decorative plate, right side | 1 | |
| 412 | 1301 z 1084 | washer for decor. plate | 2 | |
| 413 | 1331 z 956 | spacer tube | 2 | |
| 414 | — | raised head bolt CM 4 x 8 DIN 91 crp | 2 | |
| 415 | — | raised head bolt CM 4 x 12 DIN 91 crp | 2 | |
| 416 | — | spring washer A 4 DIN 137 k | 4 | |
| 417 | — | hex. nut M 4 DIN 934 k | 4 | |

Illustration 16, Group R: d) Mudguards, rear mudguard and chain case

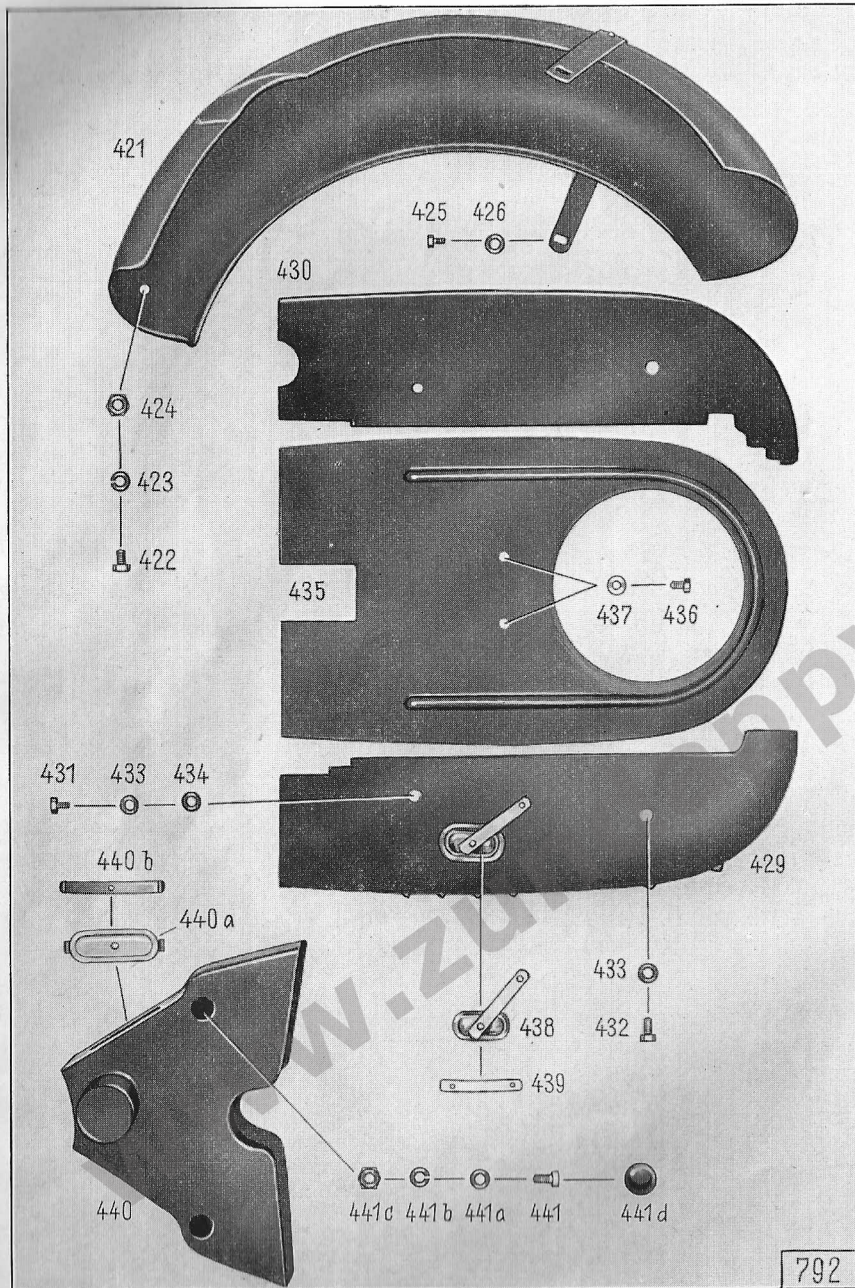

Illustration 16, Group R: d) Mudguards, rear mudguard and chain case

| Key No. | Spare Part No. | Description | Quantity | Remarks |
|----------------------|----------------|--|----------|---------|
| Rear Mudguard | | | | |
| 421 | 6370 z 204 | rear mudguard | 1 | |
| 422 | — | hex. head bolt M 8 x 15 DIN 933 k (to fasten rear mudguard to rear engine carrier) | 1 | |
| 423 | — | lock ring A 8 DIN 127 k | 1 | |
| 424 | — | hex. nut M 8 DIN 934 k | 1 | |
| 425 | — | hex. head bolt M 6 x 10 DIN 933 k (to fasten rear mudguard to frame) | 2 | |
| 426 | — | lock ring A 6 DIN 127 k | 2 | |
| Chain Case | | | | |
| 429 | 1500 z 277-8 | chain case, lower front part . . . | 1 | |
| 430 | 1500 z 259-8 | chain case, upper front part . . . | 1 | |
| 431 | — | hex. head bolt M 6 x 10 DIN 933 k (to fasten chain case front parts to swinging fork) | 2 | |
| 432 | — | hex. head bolt M 6 x 12 DIN 933 k (to fasten chain case front parts to swinging fork) | 2 | |
| 433 | — | lock washer B 6 DIN 137 k | 4 | |
| 434 | — | washer 6,4 DIN 125 k | 2 | |
| 435 | 1501 z 184-8 | chain case, rear part | 1 | |
| 436 | — | hex. head bolt M 6 x 12 DIN 933 k (to fasten chain case rear part to brake cover) | 2 | |
| 437 | — | lock washer B 6 DIN 137 k | 2 | |
| — | 616 z 281 | intermediate piece | 1 | |

Illustration 16, Group R: d) Mudguards, rear mudguard and chain case

| Key No. | Spare Part No. | Description | Quantity | Remarks |
|---------|----------------|---|----------|---------|
| 438 | 230 z 230 | cap | 1 | |
| 439 | 331 z 303 | laminated spring | 1 | |
| — | — | rivet 4 x 6 DIN 660 (to fasten laminated spring to cap and to chain case front part) | 2 | |
| — | — | washer 4,3 DIN 125 k | 1 | |
| — | — | lock washer B 5 DIN 137 k | 1 | |
| 440 | 650 z 319-7 | protective cover | 1 | |
| 440a | 230 z 232 | cap | 1 | |
| 440b | 331 z 328 | laminated spring | 1 | |
| — | — | rivet 4 x 6 DIN 660 (to fasten laminated spring to cap) | 1 | |
| 441 | — | cylindrical screw M 8 x 15 DIN 84 k (to fasten protective cover to rear engine carrier | 1 | |
| 441a | — | lock washer A 8 DIN 137 k | 1 | |
| 441b | — | lock ring A 8 DIN 127 k | 1 | |
| — | 1301 z 52 | washer 8,5 x 18 x 0,2 | var. | |
| — | 1301 z 53 | washer 8,5 x 18 x 0,3 | var. | |
| — | 1301 z 54 | washer 8,5 x 18 x 0,4 | var. | |
| 441c | — | hex. nut M 8 DIN 934 k | 1 | |
| 441d | 616 z 228 | plug (to protective cover) | 1 | |

Illustration 18, Group R: e) Front Cover, Dashboard with Cover

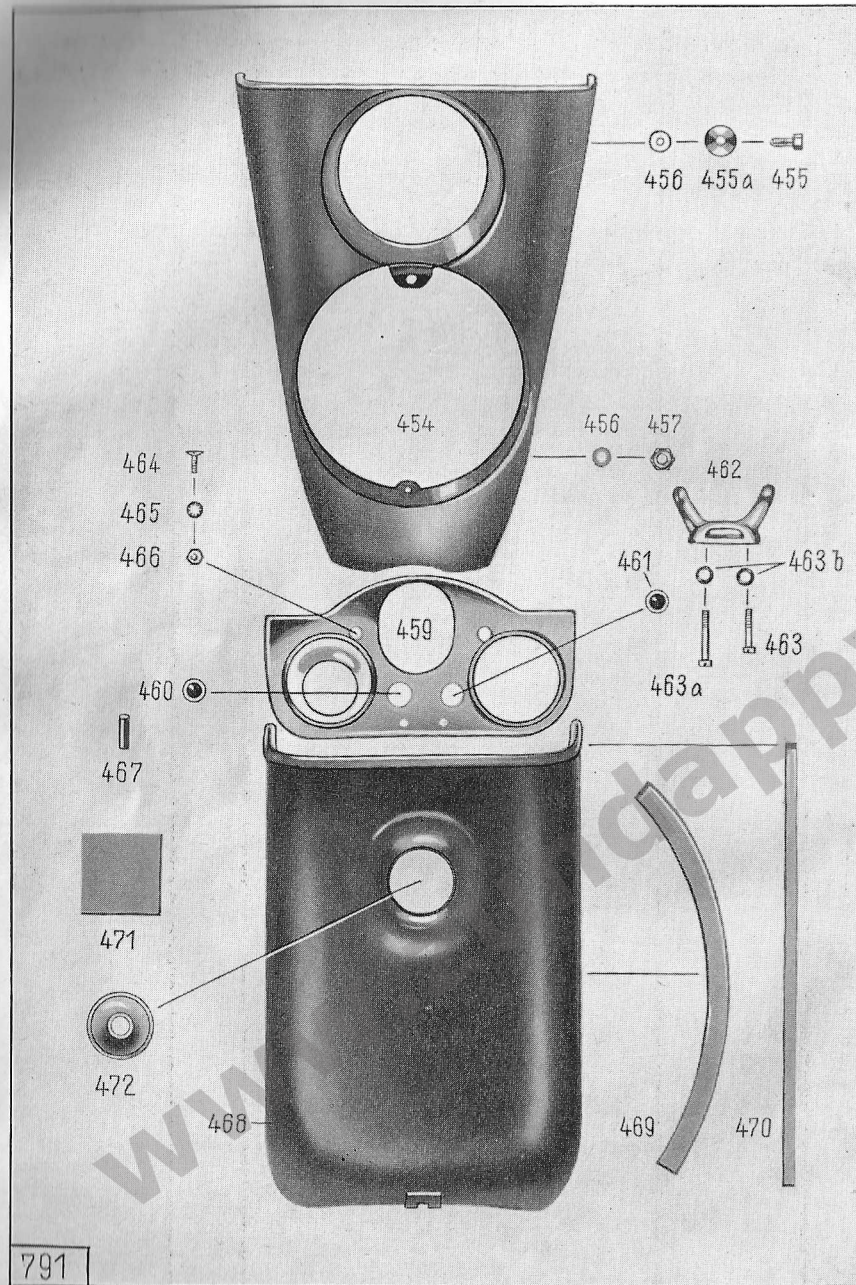

Illustration 18, Group R: e) Front Cover, Dashboard with Cover

| Key No. | Spare Part No. | Description | Quantity | Remarks |
|--|----------------|--|----------|-------------------|
| Front Cover | | | | |
| 454 | 650 k 417 | front cover | 1 | indicate colour |
| 455 | — | hex. head bolt M 6 x 15 DIN 933 k (to fasten front cover to front shield) | 2 | |
| 455a | 1301 z 1019 | washer | 2 | |
| 456 | — | lock washer B 6 DIN 137 k | 4 | |
| — | 1301 z 1039 | washer | 2 | |
| 457 | — | hex. nut M 6 DIN 934 k | 2 | |
| — | 1396 z 243 | double beading, left side | 1 | } indicate colour |
| — | 1396 z 244 | double beading, right side | 1 | |
| Dashboard | | | | |
| 459 | 483 z 322 | dashboard | 1 | |
| 460 | 1110 z 19 | inspection glass, red (for charge control lamp) | 1 | |
| 461 | 1110 z 20 | inspection glass, green (for idle control lamp) | 1 | |
| 462 | 1113 z 3 | eyelet | 1 | |
| 463 | — | cylindrical screw AM 5 x 25 DIN 84k (to fasten eyelet to dashboard) | 1 | |
| 463a | — | cylindrical screw AM 5 x 12 DIN 91 crp (to fasten and holder of control lamps to dashboard) | 1 | |
| 463b | — | lock washer A 5 DIN 137 k | 2 | |
| 464 | — | raised head bolt AM 6 x 12 DIN 91 crp (to fasten dashboard to front shield) | 3 | |
| 465 | — | toothed washer J 6,4 DIN 6797 k | 3 | |
| 466 | — | hex. nut M 6 DIN 934 k | 3 | |
| 468 | 650 z 353 | cover for dashboard | 1 | indicate colour |
| 469 | 1396 z 240 | profile rubber | 1 | indicate colour |
| 470 | 1396 z 239 | profile rubber | 1 | indicate colour |
| 471 | 1146 z 94 | rubber plate | 2 | |
| 472 | 1236 z 317 | rubber ring (for antitheft lock) | 1 | |
| — | 616 z 229 | sleeve (to steering damper) | 1 | |
| (For electrical equipment see under headlight) | | | | |

Illustration 19, Group R: e) Rear Body

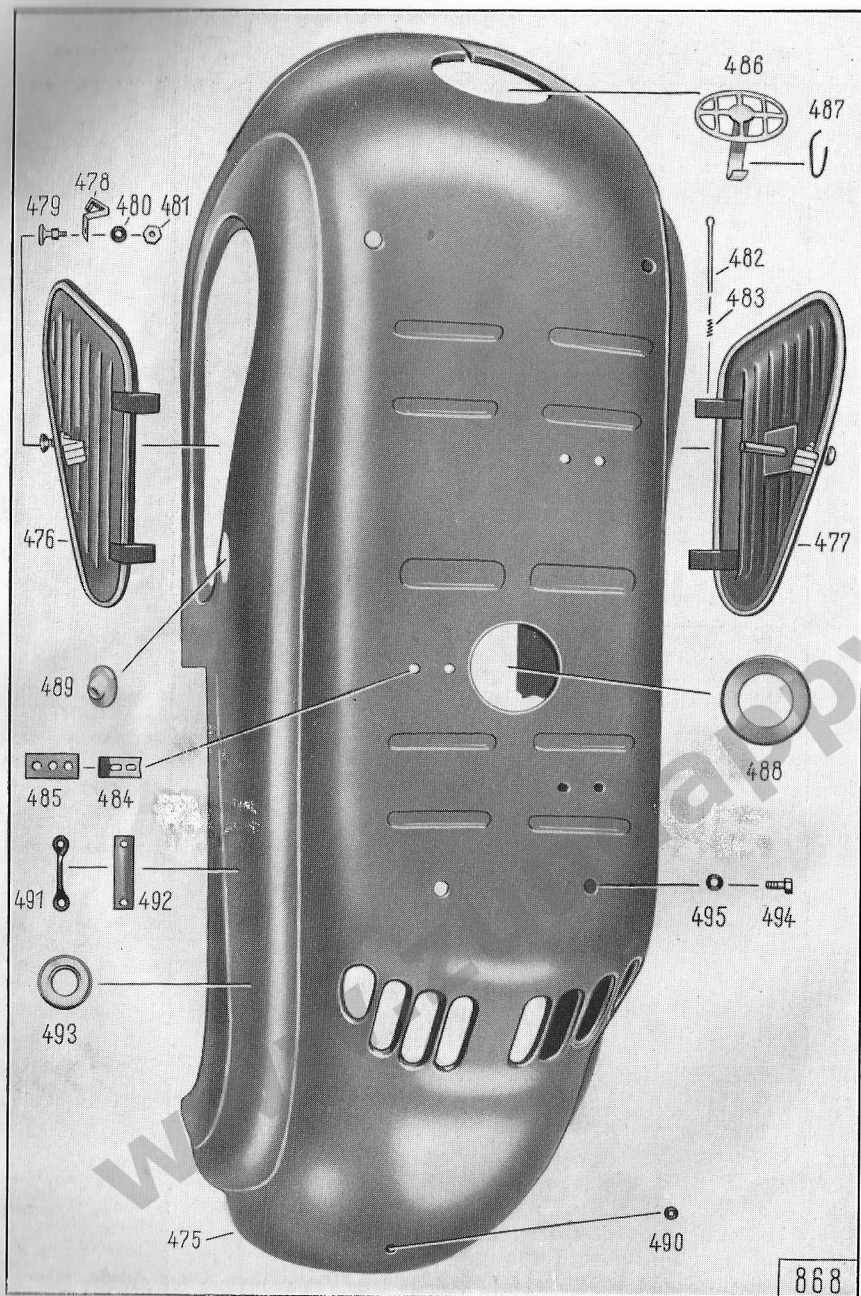

Illustration 19, Group R: e) Rear Body

| Key No. | Spare Part No. | Description | Quantity | Remarks |
|------------------|----------------|---|----------|-----------------|
| Rear Body | | | | |
| 475 | 650 z 483 | right flap with lock | 1 | indicate colour |
| 476 | 650 k 507 | left flap with lock | 1 | indicate colour |
| 477 | 650 k 491 | rear body | 1 | indicate colour |
| — | 1396 z 304 | packing rubber (for flap) | 2 | |
| 478 | 331 z 326 | lock spring | 2 | |
| 479 | 593 z 103 | lock button | 2 | |
| 480 | — | lock washer B 6 DIN 137 k | 2 | |
| 481 | — | hex. nut M 6 DIN 934 k | 2 | |
| 482 | — | split pin 4 x 60 DIN 94 k (to fasten flaps to body) | 4 | |
| 483 | 321 z 609 | thrust spring | 2 | |
| 484 | 2051 z 553 | locking angle (for dual seat) | 1 | |
| 485 | 1141 z 2130 | supporting plate | 1 | |
| — | — | hex. head bolt M 6 x 12 DIN 933 k (to fasten locking angle to body) | 2 | |
| — | — | lock washer B 6 DIN 137 k | 2 | |
| — | — | hex. nut M 6 DIN 934 k | 2 | |
| 486 | 650 z 379 | lock cap | 1 | |
| 487 | 331 z 331 | laminated spring | 1 | |
| 488 | 616 z 254 | rubber sleeve (to petrol tank seal) | 1 | |
| 489 | 616 z 244 | rubber sleeve (for fuel tap extension bolt) | 1 | |
| 490 | 1806 z 106 | rubber sleeve (for cable) | 1 | |

Illustration 19, Group R: e) Rear Body

| Key No. | Spare Part No. | Description | Quantity | Remarks |
|---------|----------------|--|----------|-----------------|
| 491 | 1111 z 224 | eyelet | 2 | Indicate colour |
| 492 | 1141 z 2140 | iron sheet | 2 | |
| — | — | raised head bolt, countersunk AM 6 x 12 DIN 91 k (to fix eyelet to rear body | 4 | |
| — | — | lock washer A 6 DIN 137 k | 4 | |
| — | — | hex. nut M 6 DIN 934 k | 4 | |
| 493 | 1243 z 10 | protecting ring | 4 | |
| — | — | hex. head bolt M 8 x 18 DIN 933 crp (to fasten body to frame, front part) | 2 | |
| 494 | — | hex. head bolt M 8 x 18 DIN 933 k (to fasten rear body to frame, rear part) | 2 | |
| 495 | — | lock washer B 8 DIN 137 k | 4 | |

www.zundappveteranclub.nl

Illustration 20, Group R: e) Dual Seat

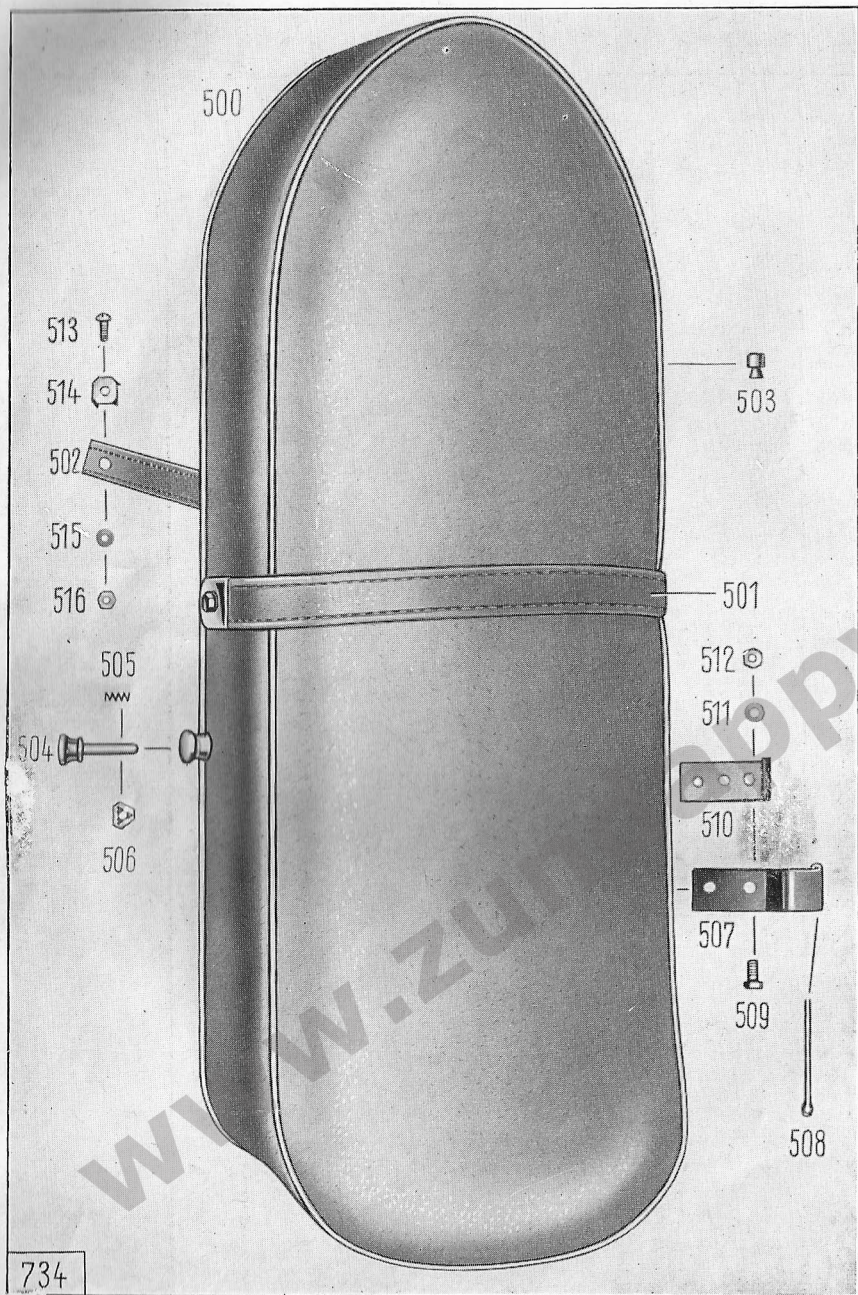

Illustration 20, Group R: e) Dual Seat

| Key No. | Spare Part No. | Description | Quantity | Remarks |
|------------------|----------------|--|----------|-----------------|
| Dual Seat | | | | |
| 500 | 6330 k 43 | dual seat complete | 1 | indicate colour |
| — | 6346 z 11 | foam rubber cushion | 1 | |
| — | 6340 z 78 | dual seat cover | 1 | indicate colour |
| — | — | raised head bolt, countersunk B 3,5 x 9,5 DIN 7973 k (to fasten dual seat cover) | 14 | |
| — | — | raised head bolt, countersunk B 3,5 x 13 DIN 7973 k (to fix dual seat cover) | 2 | |
| — | 1284 z 15 | washer | 12 | |
| — | 1147 z 806 | cover plate | 4 | |
| — | — | lock washer A 5 DIN 137 k | 4 | |
| 501 | 2360 k 1 | holding strap | 1 | indicate colour |
| — | 1143 z 105 | retaining plate | 2 | |
| — | 1141 z 2143 | clamping plate | 2 | |
| — | — | hex. head bolt M 6 x 20 DIN 933 crp (to fasten holding strap to frame of dual seat) | 2 | |
| — | — | lock washer A 6 DIN 137 k | 2 | |
| 502 | 2360 - 2 | retaining strap | 1 | indicate colour |
| 503 | 1126 z 1 | supporting bolt | 4 | |
| 504 | 590 z 109 | lock button | 1 | |
| 505 | 321 z 549 | spring | 1 | |
| 506 | 1251 z 258 | Seeger triangle circlip D 6 | 1 | |
| 507 | 1151 z 206 | joining band | 2 | |
| 508 | — | split pin 4 x 60 DIN 94 k | 2 | |
| 509 | — | hex. head bolt M 6 x 12 DIN 933 k (to fasten dual seat to rear body) | 4 | |
| 510 | 1141 z 2130 | iron sheet | 2 | |
| 511 | — | lock washer B 6 DIN 137 k | 4 | |
| 512 | — | hex. nut M 6 DIN 934 k | 4 | |
| 513 | — | screw M 5 x 12 DIN 86 k (to fix retaining strap to rear body) | 1 | |
| 514 | 1141 z 2143 | clamping plate | 1 | |
| 515 | — | washer 5,3 DIN 125 k | 1 | |
| 516 | — | hex. nut M 5 DIN 934 k | 1 | |

Illustration 21, Group R: f) Fuel Tank and Fuel Pipes



695

Illustration 21, Group R: f) Fuel Tank and Fuel Pipes

| Key No. | Spare Part No. | Description | Quantity | Remarks |
|------------------|----------------|--|----------|---------|
| Fuel Tank | | | | |
| 520 | 6230 z 135-7 | fuel tank | 1 | |
| 521 | 1850 z 103-0 | filler cap | 1 | |
| 522 | 1236 z 342 | rubber ring (for filler cap) | 1 | |
| — | — | split pin 1,5 x 12 DIN 94 k | 1 | |
| — | 1146 z 78 | felt (to fuel tank) | 1 | |
| 523 | 1390 z 116 | tie (to fasten fuel tank to frame) | 1 | |
| 524 | 1146 z 58 | support (below tie) | 4 | |
| 525 | 6010 z 162 | fuel tap | 1 | |
| 526 | 1001 z 55 | nut | 1 | |
| 527 | 120 z 211 | extension bolt (to fuel tap) | 1 | |
| 528 | 1590 z 77 | fuel hose | 1 | |

Illustration 22, Group R: h) Exhaust Set

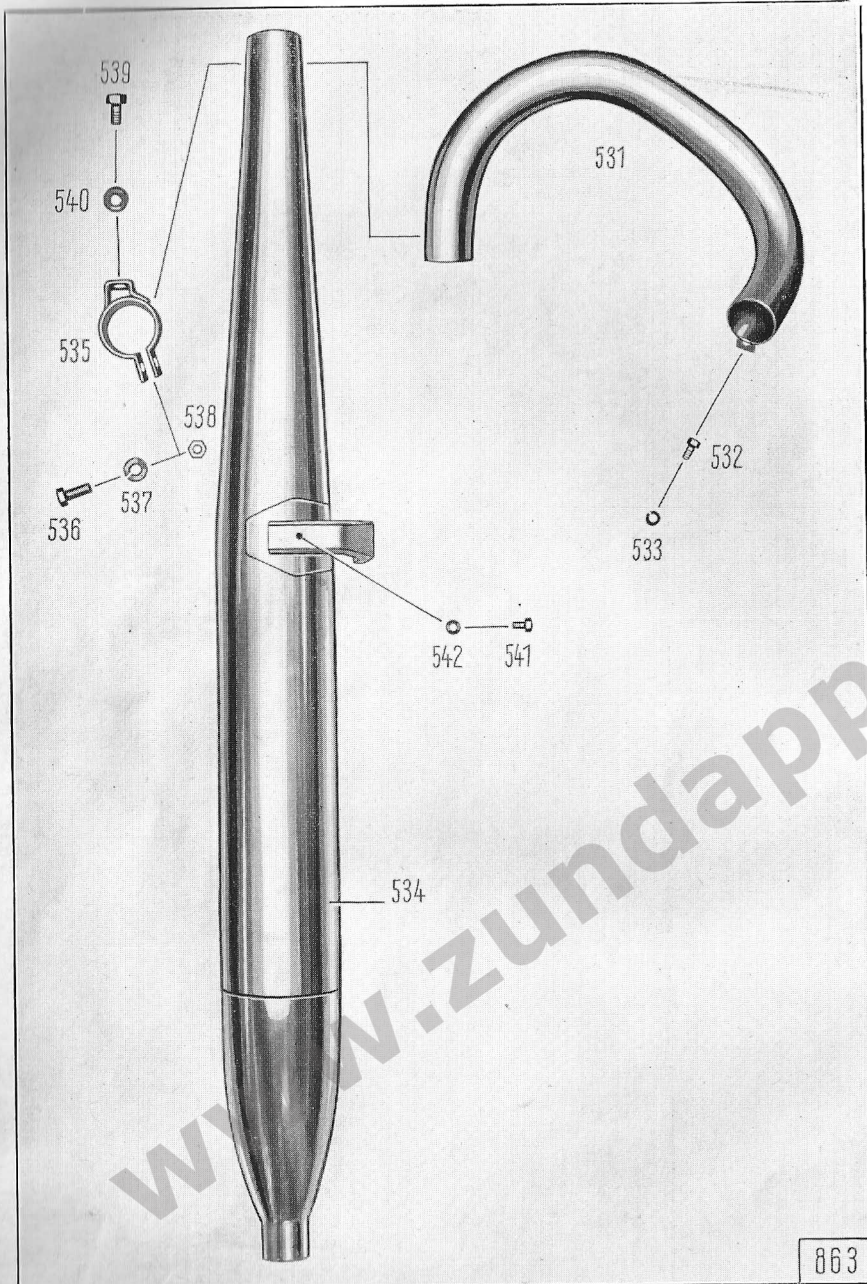

863

Illustration 22, Group R: h) Exhaust Set

| Key No. | Spare Part No. | Description | Quantity | Remarks |
|--------------------|----------------|---|----------|------------------|
| Exhaust Set | | | | |
| 531 | 1350 z 156-5 | exhaust pipe | 1 | |
| — | — | asbesto cord 2 mm ϕ (for exhaust pipe) | 1 | order per meters |
| 532 | — | hex. head bolt M 6 x 12 DIN 933 k (to fix exhaust pipe to cylinder) | 1 | |
| 533 | — | lock ring A 6 DIN 127 z | 1 | |
| 534 | 6030 z 346-4 | silencer | 1 | |
| — | 2271 k 35-4 | silencer — end piece | 1 | |
| 535 | 1440 z 130-3 | clip (to fasten silencer to exhaust pipe) | 1 | |
| 536 | — | hex. head bolt M 8 x 22 DIN 933 z | 1 | |
| 537 | — | lock ring A 8 DIN 127 z | 1 | |
| 538 | — | hex. nut M 8 DIN 934 z | 1 | |
| 539 | — | hex. head bolt M 8 x 18 DIN 933 z (to fasten silencer to left foot board) | 1 | |
| 540 | — | lock washer B 8 DIN 137 z | 1 | |
| 541 | — | hex. head bolt M 6 x 12 DIN 933 z (to fasten silencer to left foot board rear) | 1 | |
| 542 | — | lock washer B 6 DIN 137 z | 1 | |

Illustration 23, Group R: i) Front Swinging Arm Suspension

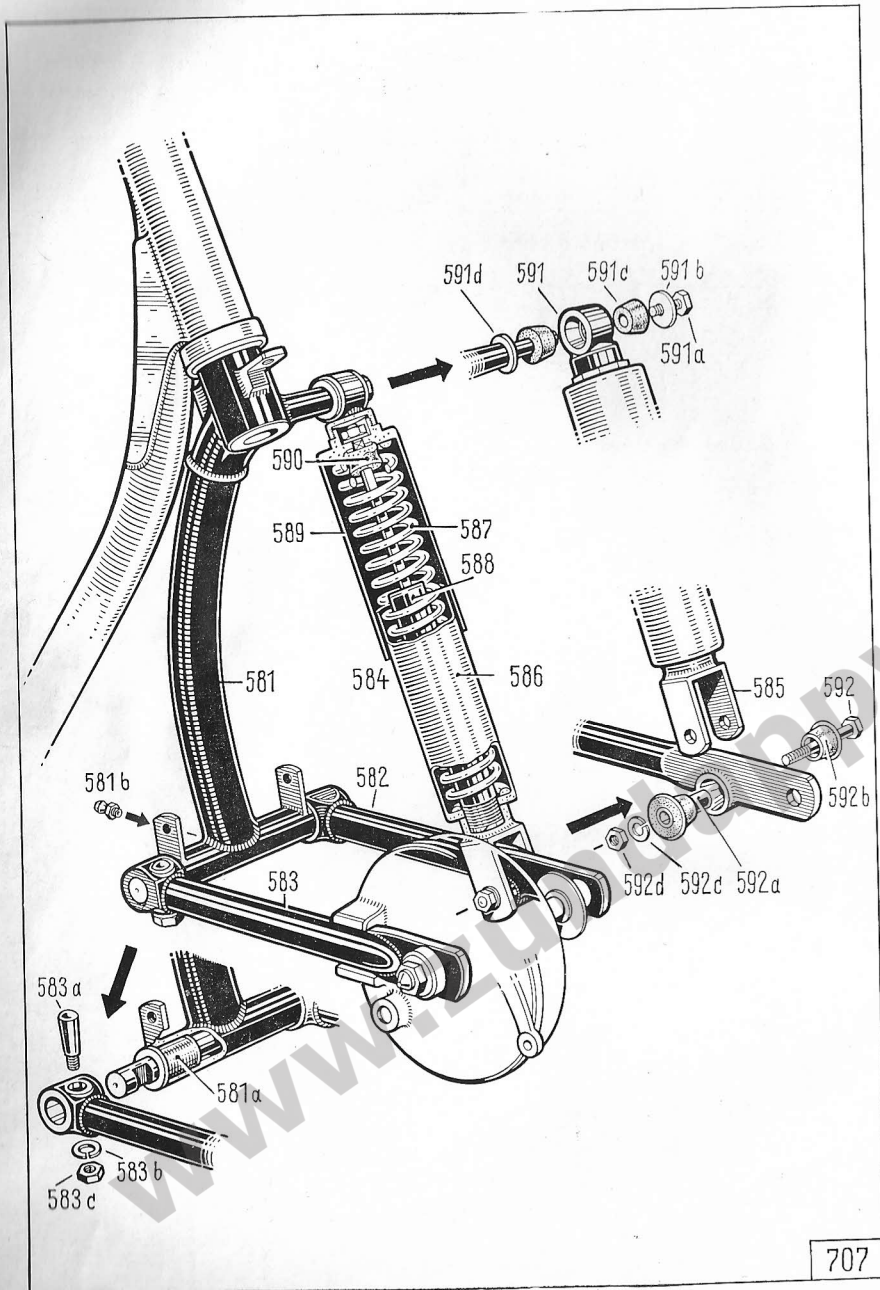

Illustration 23, Group R: i) Front Swinging Arm Suspension

| Key No. | Spare Part No. | Description | Quantity | Remarks |
|--------------------------------------|----------------|--|----------|-----------------|
| Front Swinging Arm Suspension | | | | |
| — | 6810 k 230 | front swinging arm suspension | 1 | indicate colour |
| 581 | 710 z 253 | swinging fork | 1 | indicate colour |
| 581a | 184 z 535 | bushing (to bearing tube) | 2 | |
| — | — | pin 10 x 40 DIN 1472 | 1 | |
| — | 1871 z 170 | fork race (on swinging fork at bottom) | 1 | |
| — | 1301 z 07 | washer | 1 | |
| 581b | — | grease nipple D 6 DIN 71412 | 1 | |
| — | — | seal ring A 6 x 10 DIN 7603 alu | 1 | |
| 582 | 710 k 241 | front swinging arm, left | 1 | indicate colour |
| 583 | 710 k 217 | front swinging arm, right | 1 | indicate colour |
| 583a | 121 z 1085 | cotter pin (to fix swinging arm to shaft) | 1 | |
| 583b | — | lock ring A 12 DIN 127 k | 1 | |
| 583c | — | hex. nut M 12 x 1,5 DIN 936 k | 1 | |
| — | 1870 z 52 | fork race (on top of swinging arm) | 1 | |
| — | 1236 z 336 | seal ring | 1 | |
| — | — | screw M 30 x 1 DIN 70852 k | 1 | |
| 584 | 6350 z 118 | spring unit complete with hydraulic shock absorber | 1 | |
| 585 | 550 z 103 | bar head, lower part | 1 | |
| — | — | lock ring B 16 DIN 127 k | 1 | |
| 586 | 170 z 216 | inner protective sleeve | 1 | |
| — | 1127 z 5 | spacer bolt | 6 | |
| 587 | 321 z 582 | pressure spring | 1 | |
| 588 | 6350 z 120 | hydraulic shock absorber (make Boge) | 1 | |
| 589 | 173 z 114 | outer protective sleeve | 1 | |

Illustration 23, Group R: I) Front Swinging Arm Suspension

| Key No. | Spare Part No. | Description | Quantity | Remarks |
|---------|----------------|--|----------|---------|
| 590 | 616 z 243 | rubber buffer | 1 | |
| — | 1301 z 667 | washer | 1 | |
| — | — | lock washer B 8 DIN 137 z | 3 | |
| — | — | hex. nut M 8 DIN 934 k | 1 | |
| 591 | 553 z 106 | bar head, top | 1 | |
| — | — | pin 3 x 8 DIN 1476 | 1 | |
| 591a | — | hex. head bolt M 8 x 12 DIN 933 k (to fasten spring unit to swinging fork at top) | 1 | |
| 591b | 1301 z 35 | washer | 1 | |
| 591c | 176 z 41 | rubber bushing | 2 | |
| 591d | — | washer 17 DIN 433 k | 1 | |
| 592 | — | hex. head bolt M 8 x 50 DIN 931 k (to fix spring unit to swinging arm at bottom) | 1 | |
| 592a | 1331 z 851 | spacer tube | 1 | |
| 592b | 176 z 40 | rubber bushing | 2 | |
| — | — | washer 8,4 DIN 125 k | 1 | |
| 592c | — | lock ring A 8 DIN 127 k | 1 | |
| 592d | — | hex. nut M 8 DIN 934 k | 1 | |

www.zundappveteranclub.nl

Illustration 24, Group:R: k) Handlebar and Handlevers with Cables

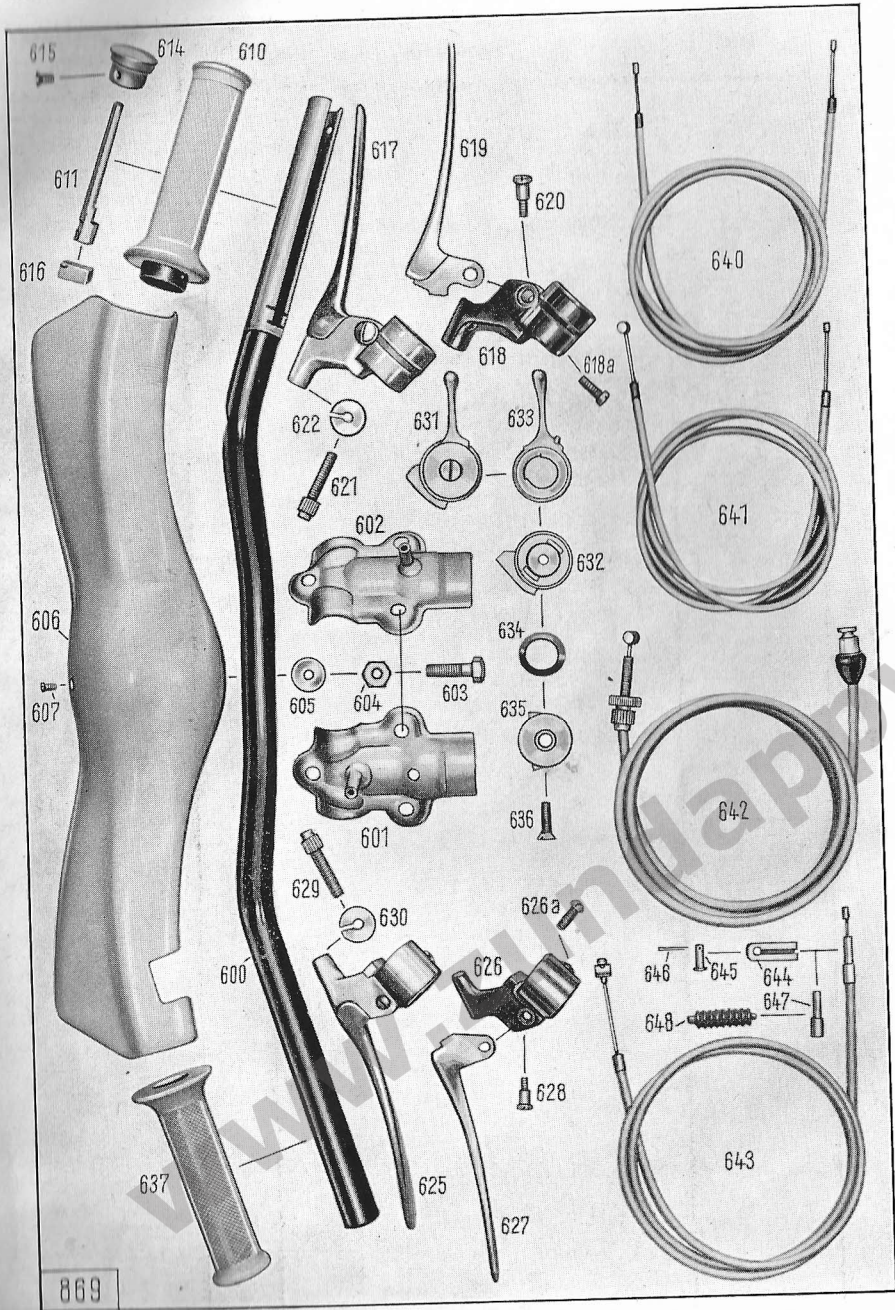

Illustration 24, Group:R: k) Handlebar and Handlevers with Cables

| Key No. | Spare Part No. | Description | | Remarks |
|-------------------|----------------|---|---|-----------------------------|
| Handlebar | | | | |
| 600 | 1371 z 165 | handlebar | 1 | |
| 601 | 820 z 12 | handlebar clamp, front | 1 | |
| 602 | 820 z 13 | handlebar clamp, rear | 1 | |
| 603 | — | hex. head bolt M 8 x 28 DIN 931 z | 3 | |
| 604 | — | lock washer B 8 DIN 137 z | 3 | |
| 605 | — | hex. nut M 8 DIN 934 z | 3 | |
| 606 | 650 z 503 | handlebar cowling | 1 | indicate colour |
| — | 1146 z 123 | rubber plate | 2 | |
| — | 1396 z 302 | rubber cord | 1 | |
| 607 | — | raised head bolt CM 4 x 8 DIN 91 crp | 2 | |
| Handlevers | | | | |
| 610 | 170 k 218 | throttle twist grip | 1 | colour of 'rubber grey |
| 611 | 2253 k 7-0 | slide block | 1 | |
| — | 2250 k 7-0 | grip tube with rubber | 1 | } colour of 'rubber grey |
| — | 2256 k 5-0 | rubber grip | 1 | |
| 614 | 2251 k 5-0 | lock cap | 1 | |
| 615 | — | raised head bolt, countersunk AM 5 x 10 DIN 91 k | 1 | |
| 616 | 2253 k 3-0 | cable support | 1 | |
| 617 | 670 z 257 | brake lever with cable adjustment | 1 | |
| 618 | 2263 k 5-0 | joining piece | 1 | |
| — | 2261 k 2-0 | brake spring | 1 | |
| — | 2261 k 3-3 | adjusting screw | 1 | |
| 618a | 2261 k 4-3 | bolt (to joining piece) | 1 | |
| 619 | 2263 k 6-0 | brake lever | 1 | |
| 620 | 2261 k 5-5 | screw for lever | 1 | |

Illustration 24, Group:R: k) Handlebar and Handlevers with Cables

| Key No. | Spare Part No. | Description | Quantity | Remarks |
|---------------|----------------|--|----------|--------------------------|
| 620a | — | hex. nut M 6 DIN 934 crp | 1 | |
| 621 | 2261 k 6-5 | adjusting screw | 1 | |
| 622 | 2263 k 7-0 | knurled nut | 1 | |
| 625 | 670 z 256 | clutch lever with cable adjustment | 1 | |
| 626 | 2263 k 1-0 | joining piece | 1 | |
| 626a | 2261 k 4-3 | bolt (for joining piece) | 1 | |
| 627 | 2263 k 2-0 | clutch lever | 1 | |
| 628 | 2261 k 7-3 | screw for lever | 1 | |
| — | — | hex. nut M 5 DIN 934 crp | 1 | |
| 629 | 2261 k 6-5 | adjusting screw | 1 | |
| 630 | 2263 k 7-0 | knurled nut | 1 | |
| 631 | 670 z 255 | starter lever | 1 | |
| 632 | 2260 k 4-0 | body | 1 | |
| 633 | 2263 k 36-4 | lever | 1 | |
| 634 | 2261 k 32-0 | lock washer | 1 | |
| 635 | 2263 k 37-0 | cover disc | 1 | |
| 636 | — | raised head bolt, countersunk M 6 x 22 DIN 88 crp | 1 | |
| 637 | 616 z 232 | fixed grip | 1 | colour of rubber grey |
| Cables | | | | |
| 640 | 6290 k 483 | cable for throttle twist grip | 1 | |
| — | — | nipple C DIN 71988 | 2 | |
| — | — | sleeve C 2,5 DIN 71987 | 2 | |
| 641 | 6290 k 484 | cable for starter lever | 1 | |
| — | — | nipple C DIN 71988 | 1 | |
| — | — | nipple D DIN 71988 | 1 | |
| — | — | sleeve C 2,5 DIN 71987 | 2 | |

Illustration 24, Group:R: k) Handlebar and Handlevers with Cables

| Key No. | Spare Part No. | Description | Quantity | Remarks |
|---------|----------------|--------------------------------------|----------|---------|
| 642 | 6290 k 486 | cable for clutch | 1 | |
| — | 144 z 25 | nipple cage | 1 | |
| — | 1064 z 101 | nipple | 1 | |
| — | 1064 z 102 | nipple | 1 | |
| — | 173 z 109 | sleeve | 1 | |
| — | 1806 z 08 | rubber sleeve | 1 | |
| — | 616 z 236 | rubber cover | 1 | |
| — | 2261 k 1-3 | adjusting screw | 1 | |
| — | 2263 k 3-0 | knurled nut | 1 | |
| 643 | 6290 z 467 | cable for front brake | 1 | |
| — | 144 z 04 | cable end | 1 | |
| — | — | nipple cage A DIN 71988 | 1 | |
| — | — | nipple B 2,3 DIN 71988 | 1 | |
| — | — | sleeve C 3 DIN 71987 | 1 | |
| 644 | 551 z 108 | yoke | 1 | |
| 645 | 131 z 516 | bolt (to yoke) | 1 | |
| 646 | — | split pin 1,5 x 15 DIN 94k | 1 | |
| 647 | 171 z 442 | sleeve | 1 | |
| 648 | 616 z 263 | rubber cover | 1 | |

736

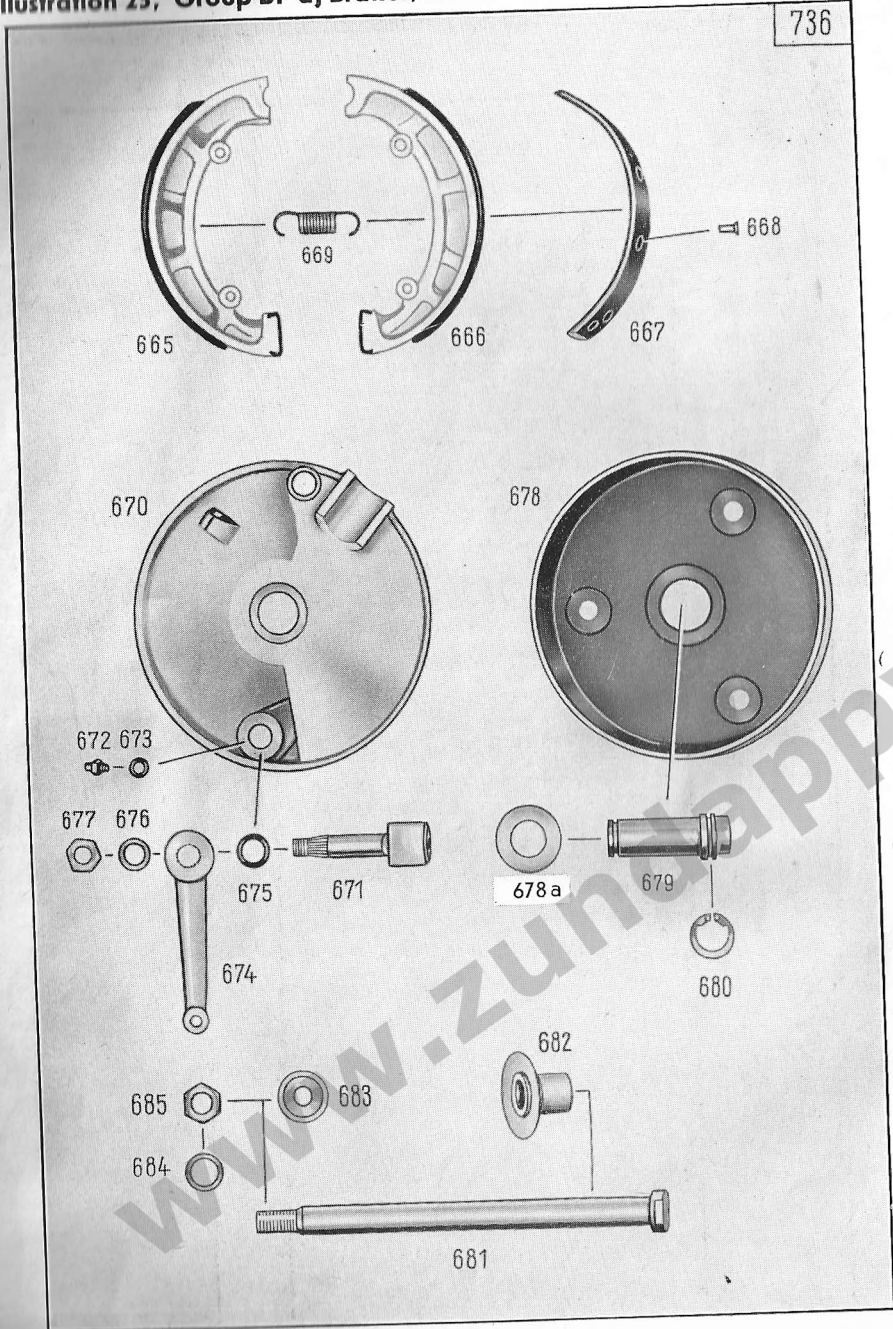

| Key No. | Spare Part No. | Description | Quantity | Remarks |
|------------------|----------------|---|----------|---------------------------|
| Handbrake | | | | |
| 665 | 20 z 108 | brake shoe with lining, left | 1 | } lining fixed with paste |
| 666 | 20 z 109 | brake shoe with lining, right | 1 | |
| 667 | 49 z 12 | brake lining | 2 | to be riveted |
| 668 | 1044 z 10 | cylindrical rivet | 12 | to be riveted |
| 669 | 321 z 310 | pull spring (between brake shoes) | 2 | |
| 670 | 230 z 233 | brake cover | 1 | |
| 671 | 1100 z 110 | brake cam with bracket | 1 | |
| 672 | 1080 z 1 | grease nipple | 1 | |
| 673 | — | seal ring A 6 x 10 DIN 7603 | 1 | |
| 674 | 671 z 324 | brake operating lever | 1 | |
| 675 | 1236 z 6 | rubber buffer (between brake lever and brake cover) | 1 | |
| 676 | — | lock ring A 10 DIN 127 k | 1 | |
| 677 | — | hex. nut M 10 DIN 934 k | 1 | |
| 678 | 1791 z 203 | brake drum | 1 | |
| 678a | 1301 z 640 | washer (between brake cover and brake drum) | 1 | |
| 679 | 121 z 1109 | bearing bushing to brake drum | 1 | |
| 680 | 1251 k 260 | Seeger V circlip | 1 | |
| — | 1301 z 1030 | washer | 1 | |
| — | — | Sg. ring 18 x 1,2 DIN 471 k | 1 | |
| 681 | 131 z 537 | front wheel axle | 1 | |
| 682 | 1330 z 193 | spacer tube 23,7 mm long | var. | |
| — | 1330 z 194 | spacer tube 24,0 mm long | var. | |
| — | 1330 z 195 | spacer tube 24,3 mm long | var. | |
| — | — | washer 17 DIN 125 k | 1 | |
| 683 | 1781 z 155 | pressure plate | 1 | |
| 684 | — | lock washer B 12 DIN 137 k | 1 | |
| 685 | — | hex. nut M 12 x 1,5 DIN 934 k | 1 | |

Illustration 26, Group B: a) Brakes, Foot Brake

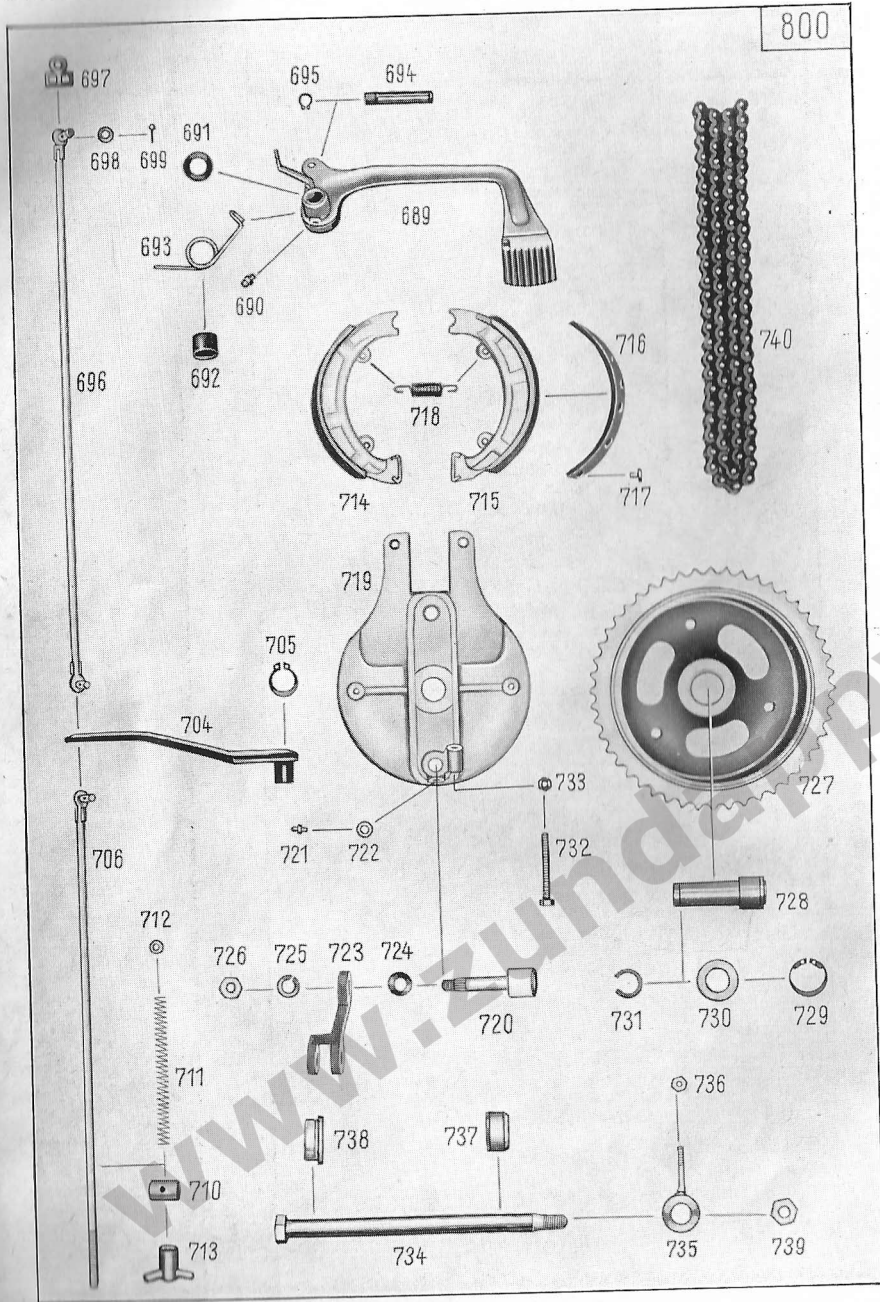

Illustration 26, Group B: a) Brakes, Foot Brake

| Key No. | Spare Part No. | Description | Quantity | Remarks |
|-------------------|----------------|--|----------|--------------------|
| Foot Brake | | | | |
| 689 | 700 k 112 | foot brake lever | 1 | |
| 690 | 1080 z 1 | grease nipple | 1 | |
| — | — | seal ring A 6 x 10 DIN 7603 | 1 | |
| 691 | 1236 z 324 | gasket | 1 | |
| 692 | 1236 z 325 | gasket | 1 | |
| 693 | 321 z 556 | bolt for footbrake lever | 1 | |
| 694 | 121 z 1141 | bearing bolt for foot brake lever | 1 | |
| 695 | — | Seeger circlip 10 x 1 DIN 471 | 2 | |
| 696 | 1650 k 124 | brake rod with stop clamp, front | 1 | |
| 697 | 1111 z 01 | stop clamp | 2 | |
| 698 | — | washer 6,4 DIN 125 z | 2 | |
| 699 | — | split pin 2 x 12 DIN 94 z (to fasten brake rod to brake lever) | 2 | |
| 704 | 700 z 110 | intermediate lever to foot brake | 1 | |
| 705 | — | Seeger circlip 12 x 1 DIN 471 (to fix intermediate lever to frame) | 1 | |
| 706 | 1650 k 114 | rear brake rod with stop clamp | 1 | |
| 697 | 1111 z 01 | stop clamp | 1 | |
| 698 | — | washer 6,4 DIN 125 z | 1 | |
| 699 | — | split pin 2 x 12 DIN 94 z | 1 | |
| 710 | 121 z 1046 | brake lever bolt (to rear wheel brake lever) | 1 | |
| 711 | 321 z 88 | spring | 1 | |
| 712 | 1241 z 34 | ring | 1 | |
| 713 | 1023 z 103 | toggle nut (to fasten brake rod to rear wheel brake lever) | 1 | |
| 714 | 20 z 108 | brake shoe with lining, left | 1 | } fixed with paste |
| 715 | 20 z 109 | brake shoe with lining, right | 1 | |
| 716 | 49 z 12 | brake lining | 2 | to be riveted |
| 717 | 1044 z 10 | cylindrical rivet | 12 | |

Illustration 26, Group B: a) Brakes, Foot Brake

| Key No. | Spare Part No. | Description | Quantity | Remarks |
|---------|----------------|---|----------|---------|
| 718 | 321 z 310 | pullspring (between the brake shoes) | 2 | |
| 719 | 230 z 226 | brake cover | 1 | |
| 720 | 1100 z 8 | brake cam with iron sheet | 1 | |
| 721 | 1080 z 1 | grease nipple | 1 | |
| 722 | — | seal ring A 6 x 10 DIN 7603 | 1 | |
| 723 | 671 z 011 | brake lever | 1 | |
| 724 | 1236 z 6 | rubber buffer (between brake lever and brake cover) | 1 | |
| 725 | — | lock ring A 10 DIN 127 k | 1 | |
| 726 | — | hex. nut M 10 DIN 934 k | 1 | |
| 727 | 1791 z 211 | brake drum (48 teeth) | 1 | |
| 728 | 121 z 1115 | bearing bushing (to brake drum) | 1 | |
| 729 | 1251 k 261 | Seeger V circlip | 1 | |
| 730 | 1301 z 640 | washer (between brake cover and brake drum) | 1 | |
| 731 | 1251 z 29 | snap ring (to bearing bushing) | 1 | |
| 732 | — | hex. head bolt M 6 x 55 DIN 933 k (within brake cover to chain tension) | 1 | |
| 733 | — | hex. nut M 6 DIN 934 k | 1 | |
| 734 | 131 z 510 | rear wheel axle | 1 | |
| 735 | 1111 z 209 | chain tension | 1 | |
| 736 | — | hex. nut M 6 DIN 934 k | 2 | |
| 737 | 1243 z 7 | spacer ring | 1 | |
| 738 | 1231 z 309 | tensioning ring | 1 | |
| 739 | — | hex. head bolt M 12 x 1,5 DIN 934 k (to rear wheel axle) | 1 | |
| 740 | — | single roller chain 1 x 12,7 x 7,75 DIN 8187, 98 links with lock | 1 | |
| — | — | cranked double link 1 C 12,7 x 7,75 DIN 8187 | 1 | |
| — | — | link 1 E 12,7 x 7,75 DIN 8187 | 1 | |

Illustration 27, Group B: b) Wheels

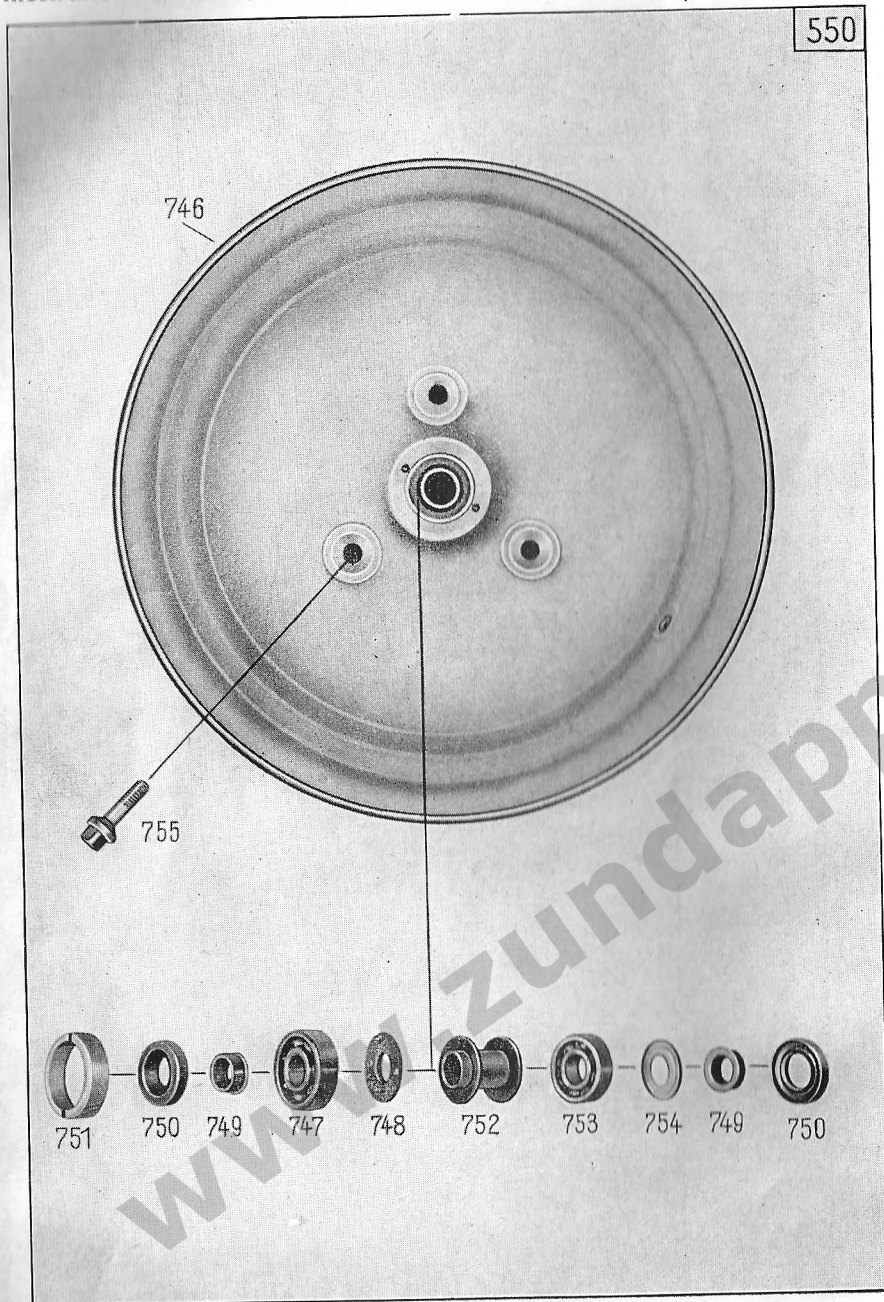

Illustration 27, Group B: b) Wheels

| Key No. | Spare Part No. | Description | Quantity | Remarks |
|---------------|----------------|--|----------|---|
| Wheels | | | | |
| 746 | 6660 z 87 | wheel without tire and tube | 2 | |
| 747 | — | roller bearing 6302 DIN 625 | 2 | |
| 748 | 1301 z 641 | compensating washer 15,2x36,6x0,1 | var. | } between roller bearing and spacer bushing |
| — | 1301 z 642 | compensating washer 15,2x36,6x0,2 | var. | |
| — | 1301 z 643 | compensating washer 15,2x36,6x0,3 | var. | |
| 749 | 171 z 412 | spacer bushing | 4 | |
| 750 | — | radial seal ring with dust lip A 20 x 35 x 7 DIN 6503 | 4 | |
| 751 | 1011 z 84 | ring nut | 2 | |
| 752 | 1330 z 166 | spacer tube | 2 | |
| 753 | — | roller bearing 6202 DIN 625 | 2 | |
| 754 | 1231 z 305 | Nilos-ring | 2 | |
| 755 | 1551 z 411 | sqare screw (to fasten wheels) | 6 | |

Illustration 28, Group E: a) Electrical Equipment, Headlight

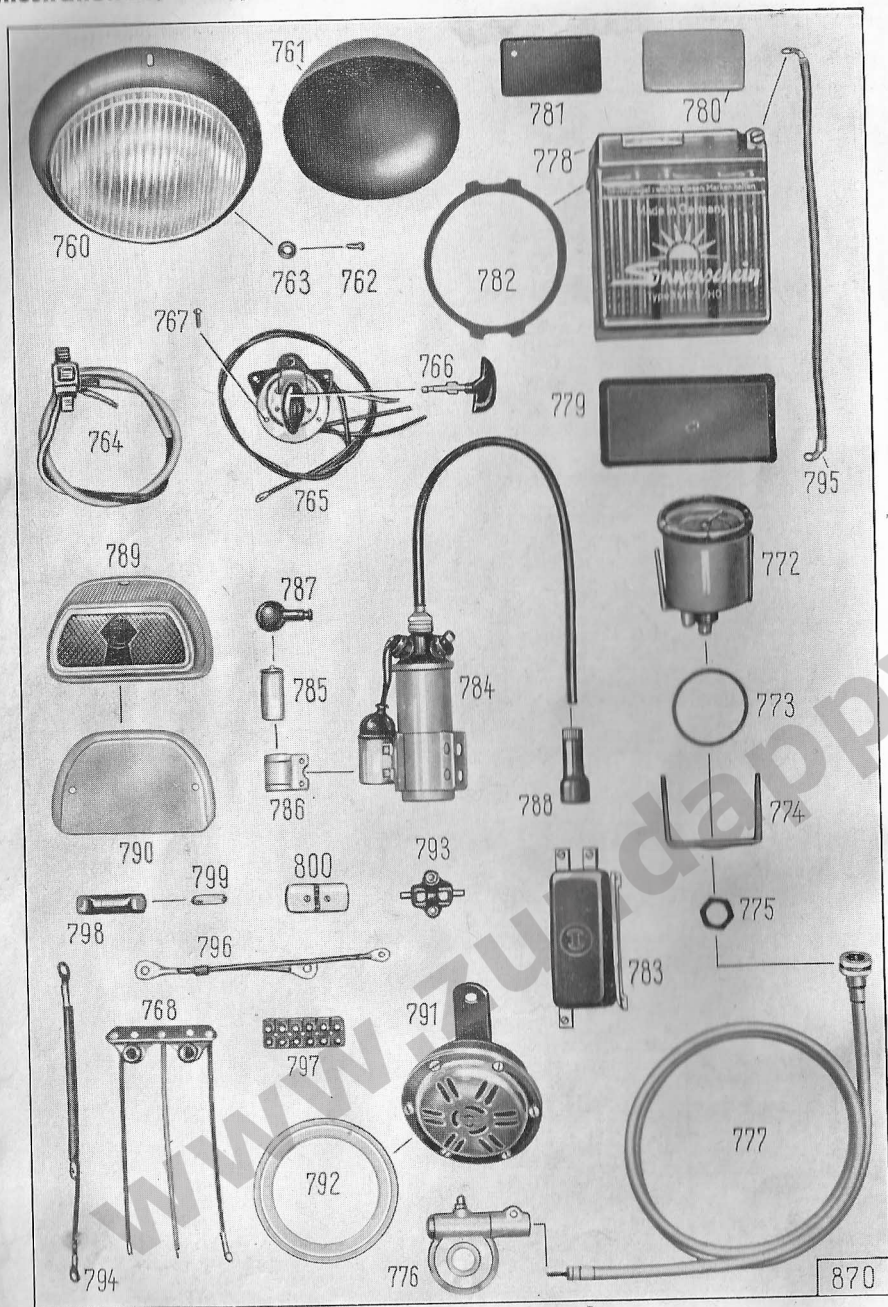

Illustration 28, Group E: a) Electrical Equipment, Headlight

| Key No. | Spare Part No. | Description | Quantity | Remarks |
|----------------------|----------------|--|----------|------------|
| Headlight | | | | |
| 760 | 6090 z 105 | headlight without bulbs, make Hella | 1 | |
| — | 2310 k 30-0 | reflector | 1 | |
| — | 2311 k 33-4 | reflector ring | 1 | |
| — | 2317 k 7-0 | headlight lens | 1 | |
| — | 2316 k 8-0 | rubber ring to headlight lens | 1 | |
| — | 2310 k 38-3 | bulb socket (to Bilux bulb) | 1 | |
| — | 2311 k 35-0 | spring (to bulb socket) | 1 | |
| 761 | 2316 k 7-0 | rubber cap | 1 | |
| — | 2311 k 36-8 | ring (to rubber cap) | 1 | |
| — | 6090 k 140-0 | headlight without bulbs, make Scharlach | 1 | |
| — | 2310 k 68-0 | reflector | 1 | |
| — | 2311 k 51-4 | reflector ring | 1 | |
| — | 2317 k 12-0 | headlight lens | 1 | |
| — | 2316 k 11-0 | rubber ring (to headlight lens) | 1 | |
| — | 2310 k 69-3 | bulb socket (to Bilux bulb) | 1 | |
| — | 2311 k 52-3 | spring (to socket) | 2 | |
| — | 2311 k 53-8 | ring (to rubber cap) | 1 | |
| 761 | 2316 k 7-0 | rubber cap | 1 | |
| — | — | Bilux bulb | | |
| — | — | B 12 V 35/35 W DIN 72601 | 1 | Osram 7327 |
| — | — | parking light bulb | | |
| — | — | H 12 V 2 W DIN 72601 | 1 | Osram 3796 |
| 762 | — | raised head bolt | | |
| — | — | AM 4 10 DIN 91 crp (to fasten headlight to front cover) | 3 | |
| 763 | 1281 z 365 | washer | 3 | |
| 764 | 6160 z 230 | dip switch with set of cables | 1 | |
| — | 2340 k 11-0 | set of cables (5 lines) | 1 | |
| — | 2346 k 1 | rubber sleeve | 1 | |
| within the dashboard | | | | |
| 765 | 6160 z 180 | starter-ignition light switch with key and cable | 1 | |
| 766 | 2310 z 50 | ignition switch | 1 | |
| 767 | — | raised head bolt, countersunk AM 4 x 12 DIN 91 crp (to fasten switch to dashboard) | 2 | |
| 768 | 6160 z 186 | holder (for charge and idle control lamps) | 1 | |
| — | — | cylindrical screw | | |
| — | — | AM 4 x 10 DIN 84 k (to fix holder to dashboard) | 1 | |
| — | — | lock washer A 4 DIN 137 k | 1 | |
| — | 2310 k 51 | light bulb 12 V 3 W | 2 | Osram 3766 |

Illustration 28, Group E: a) Electrical Equipment, Battery, Regulator, Ignit. Coil, Speedometer

| Key No. | Spare Part No. | Description | Quantity | Remarks |
|----------------------|----------------|---|----------|---|
| Speedometer | | | | |
| 772 | 6770 z 57 | speedometer with incorporated lighting | 1 | |
| — | 6770 z 58 | speedometer indicating miles | 1 | |
| 773 | 2426 k 2-0 | rubber ring | 1 | |
| 774 | 2421 k 7 | bracket | 1 | |
| 775 | 2421 k 6-2 | hex. nut (to bracket) | 1 | |
| — | 2424 k 1-0 | bulb socket | 1 | |
| — | — | light bulb J 12 V 2 W DIN 601 | 1 | Osram 3898 |
| 776 | 6780 z 102 | speedometer drive (to rear wheel) | 1 | |
| 777 | 6790 z 108 | drive cable | 1 | |
| — | 616 z 247 | rubber sleeve (for clutch lever) | 1 | |
| — | 1806 z 108 | rubber sleeve (for speedometer drive) | 1 | |
| Battery | | | | |
| 778 | 6060 z 104 | battery 6 V 11 AH make Sonnenschein No. 3 MR 5 H | 2 | } var. |
| — | 6060 z 106 | battery 6 V 12 AH make Bosch No. BA/SA 6/12 | 2 | |
| 779 | 1146 k 95 | battery base | 2 | } replacement for 1146 z 77 and 1141 z 2125 |
| 780 | 1146 z 77 | rubber plate | 2 | |
| 781 | 1141 z 2125 | thrust plate | 2 | |
| — | 1146 z 124 | rubber plate | 2 | |
| 782 | 1236 z 337 | rubber ring | 2 | |
| Regulator | | | | |
| 783 | 6160 z 225 | regulator (for starter-generator) | 1 | |
| — | — | cylindrical screw AM 4 x 6 DIN 84 k (to fasten regulator to front shield) | 3 | |
| — | — | cylindrical screw AM 4 x 6 DIN 84 k (to fasten cables to regulator) | 3 | |
| — | — | lock ring A 4 DIN 127 k | 6 | |
| Ignition Coil | | | | |
| 784 | 6180 z 19-0 | ignition coil with ignition cable | 1 | |
| 785 | 2290 k 55-0 | condenser | 1 | |
| 786 | 2291 k 30-3 | fixing clip | 1 | |
| — | — | cylindrical screw AM 4 x 6 DIN 84 k | 2 | |
| — | — | lock ring A 4 DIN 127 k | 2 | |
| 787 | 2296 k 9 | rubber cap | 1 | |
| 788 | 6080 z 102 | spark plug cover (Beru L 4 Z) | 1 | |
| — | — | hex. head bolt M 6 x 15 DIN 933 z (to fix ignition coil to frame) | 2 | |
| — | — | lock ring A 6 DIN 127 k | 2 | |
| — | — | hex. nut M 6 DIN 934 k | 2 | |

Illustration 28, Group E: a) Electrical Equipment, Brakelight Switch, Taillight, Horn

| Key No. | Spare Part No. | Description | Quantity | Remarks |
|-----------------------------------|----------------|---|----------|------------|
| Taillight | | | | |
| 789 | 6110 z 61 | brake tail- and licence plate light | 1 | |
| — | 2310 k 17 | cap | 1 | |
| 790 | 2326 k 8 | supporting plate | 1 | |
| — | — | toothed washer A 5,3 DIN 6797 k | 2 | |
| — | — | hex. nut M 5 DIN 934 k | 2 | |
| — | — | bulb L 12 V 5 W DIN 72601 (as taillight) | 1 | Osram 6418 |
| — | — | bulb K 12 V 15 W DIN 72601 (as brakelight) | 1 | Osram 6451 |
| Horn | | | | |
| 791 | 6130 z 22 | horn | 1 | |
| 792 | 1236 z 327 | rubber ring (between horn and front cover) | 1 | |
| — | 631 z 650 | cable support | 1 | |
| — | — | hex. head bolt M 8 x 20 DIN 933 k (to fasten horn and cable support to front cover) | 1 | |
| — | — | lock ring A 8 DIN 127 k | 1 | |
| Brakelight Pressure Switch | | | | |
| 793 | 6160 z 158 | brakelight pressure switch | 1 | |
| — | 1141 z 2100 | fixing plate | 1 | |
| — | — | screw with button head AM 4 x 10 DIN 86 k (to fasten brakelight pressure switch to fixing plate) | 2 | |
| — | — | lock washer A 4 DIN 137 k | 2 | |

Illustration 28, Group E: a) Electrical Equipment, Wires

| Key No. | Spare Part No. | Description | Quantity | Remarks |
|---|----------------|--|----------|---|
| Electric Wires | | | | |
| — | 760 z 313 | set of cables complete | 1 | |
| 794 | 760 z 314 | cable complete (ignition switch 30 — battery + — regulator switch) | 1 | |
| 795 | 760 k 302 | cable complete (battery + — bat. tery —) | 1 | |
| 796 | 760 k 303 | cable complete (battery and regu- lator case — earth) | 1 | |
| — | 760 k 277 | cable complete double plug — taillight, 2 lines) | 1 | |
| — | 1396 z 51 | strap | 5 | } for cable set and bowden cables |
| — | 1396 z 216 | strap | 1 | |
| 797 | — | wire connexion B 6 DIN 72586 | 1 | |
| — | — | cylindrical screw AM 3 x 15 DIN 84 k (to fix wire connexion to front shield) | 1 | |
| — | — | lock washer A 3 DIN 137 k | 1 | |
| — | — | hex. nut M 3 DIN 934 k | 1 | |
| 798 | 6160 z 237 | cable connection | 1 | |
| 799 | — | fuse 8 DIN 72581 (in cable connexion) | 1 | |
| 800 | 6160 z 192 | half of double plug | 1 | |
| 800 | 6160 z 193 | half of double plug | 1 | |
| — | 1596 z 421 | sleeve (for double plug) | 1 | |
| (cable looms and hoses ordered per meters) | | | | |
| — | — | wire NYAF 1,30 m (80 lines) | | colour red |
| — | — | wire B 1,5 DIN 72551 2,390 m | | colour yellow |
| — | — | wire B 1,5 DIN 72551 0,880 m | | colour green |
| — | — | wire B 1,5 DIN 72551 1,510 m | | colour blue |

Illustration 28, Group E: a) Electrical Equipment, Wires

| Key No. | Spare Part No. | Description | Quantity | Remarks |
|---------|----------------|---|----------|------------------------|
| — | — | wire B 1,5 DIN 72551 1,080 m | | colour blue/red |
| — | — | wire B 1,5 DIN 72551 0,475 m | | colour red |
| — | — | wire B 1,5 DIN 72551 0,750 m | | colour black |
| — | — | wire B 1,5 DIN 72551 1,540 m | | colour yellow/green |
| — | — | wire B 1,5 DIN 72551 0,135 m | | colour red/yellow |
| — | — | wire B 1,5 DIN 72551 1,020 m | | colour black/white |
| — | — | wire, double lines 1,065 | | colour black |
| — | 144 z 30 | cable shoe | 1 | |
| — | 144 z 31 | cable shoe | 4 | |
| — | 144 z 32 | cable shoe | 3 | |
| — | 144 z 36 | cable shoe | 1 | |
| — | — | cable shoe A 4 x 2 DIN 46211 | 2 | tinned |
| — | — | cable shoe A 6 x 4,5 DIN 46211 | 3 | tinned |
| — | 1806 z 01 | connexion protector | 1 | |
| — | — | connexion protector H DIN 72311 | 2 | |
| — | — | rubber hose 12 x 10 180 mm | | |
| — | — | rubber hose 10 x 8 340 mm | | |
| — | — | rubber hose 10 x 7 90 mm | | |
| — | — | rubber hose 8 x 6 260 mm | | |
| — | — | insulating hose 4,5 x 3,5 60 mm | | |
| — | — | insulating hose B 4 x 5 sw DIN 40621 750 mm | | |
| — | — | insulating hose B 8 x 9,4 sw DIN 40621 520 mm | | |
| — | — | insulating hose B 14 x 16 sw DIN 40621 1030 mm | | |

Illustration 29, Gruppe E: a) Electrical Equipment, Starter-Generator

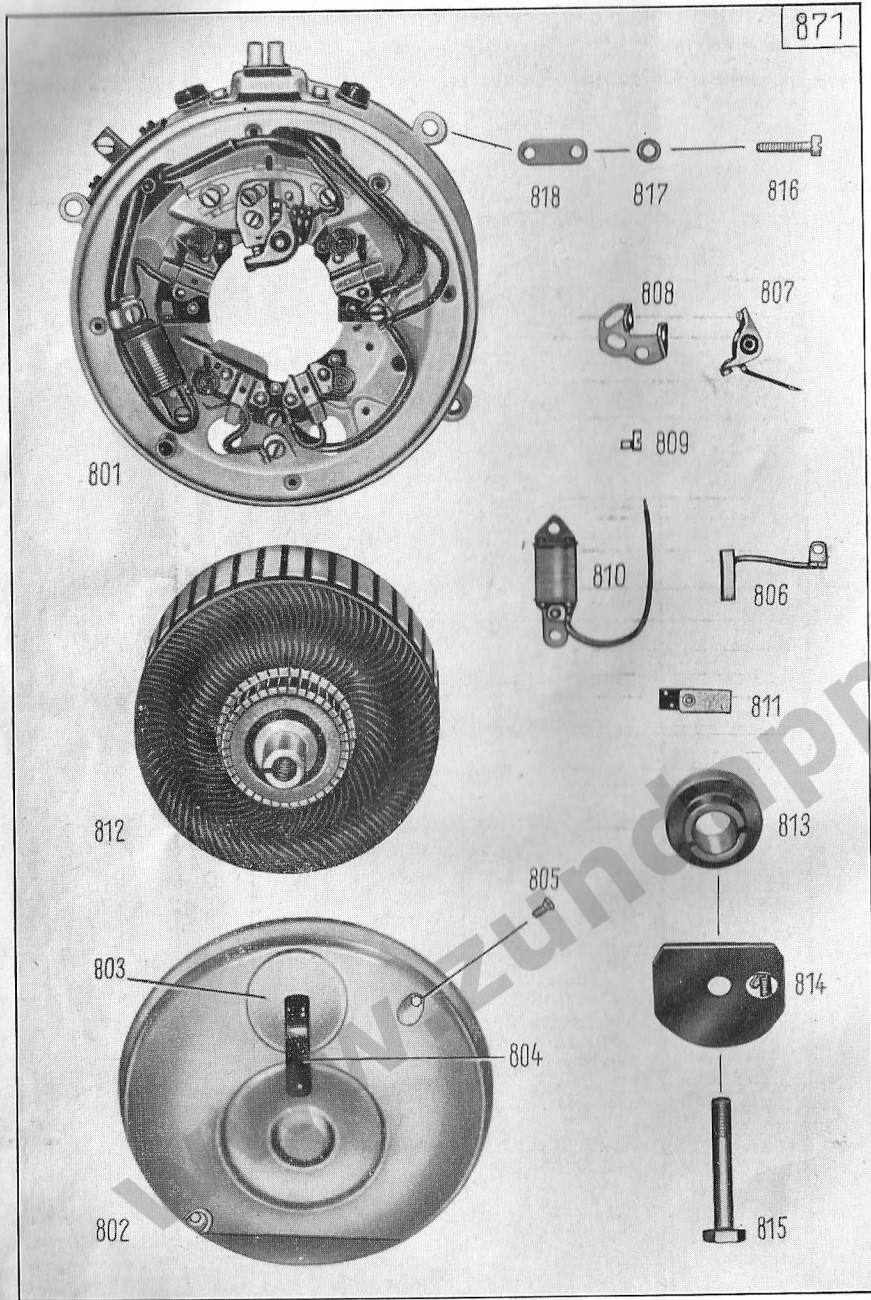

Illustration 29, Gruppe E: a) Electrical Equipment, Starter-Generator

| Key No. | Spare Part No. | Description | Quantity | Remarks |
|--------------------------|----------------|---|----------|--|
| Starter-Generator | | | | |
| 801 | 6210 z 5 | starter-generator model Bosch LA-ZB 12/100 L | 1 | |
| 802 | 2291 k 44-3 | protective cover | 1 | |
| 803 | 2291 k 34-3 | plate (for protective cover) | 1 | |
| 804 | 2291 k 35-0 | laminated spring | 1 | |
| — | 2291 k 36-0 | rivet (to fix laminated spring to protective cover) | 1 | |
| 805 | — | raised head bolt, countersunk M 4 x 6 DIN 88 k (to fasten pro- tective cover) | 2 | |
| 806 | 2290 k 58-0 | carbon brush with cable | 4 | |
| — | 2291 k 37-0 | thrust spring (to carbon brush) | 4 | |
| 807 | 2290 z 30-6 | interruptor lever with contact | 1 | |
| 808 | 2290 k 35-6 | contact angle | 1 | |
| 809 | 2291 k 26-3 | eccentric screw | 1 | |
| — | — | cylindrical screw M 4 x 8 DIN 84 k | 1 | |
| 810 | 2290 k 59-0 | resistance | 1 | |
| 811 | 2290 k 36-0 | laminated spring with felt | 1 | |
| — | 2291 k 15-2 | rivet (to laminated spring) | 2 | |
| 812 | 2290 k 60-0 | armature | 1 | |
| 813 | 2290 k 61-0 | interruptor cam | 1 | |
| 814 | 2290 k 62-0 | flyball governor | 1 | |
| — | 2291 k 38-0 | spring (to flyball governor) | 1 | |
| — | — | spring 4 x 5 DIN 6888 (to fasten armature to crankshaft) | 1 | |
| 815 | 2291 k 39-2 | hex. head bolt (to fix armature) | 1 | |
| — | — | spare plug with gasket 14 DIN 72502 | 1 | { Bosch W 225 T 1 or Beru 225/14 u 2 |
| 816 | — | cylindrical screw AM 6 x 25 DIN 84 k (to fasten starter-generator to crankcase) | 4 | |
| 817 | — | lock washer A 6 DIN 127 k | 4 | |
| 818 | 1281 z 391 | washer (to fasten clutch cable to starter) | 1 | |
| — | 1806 z 110 | connexion protector | 1 | |

Illustration 30, Group W: a) Tools

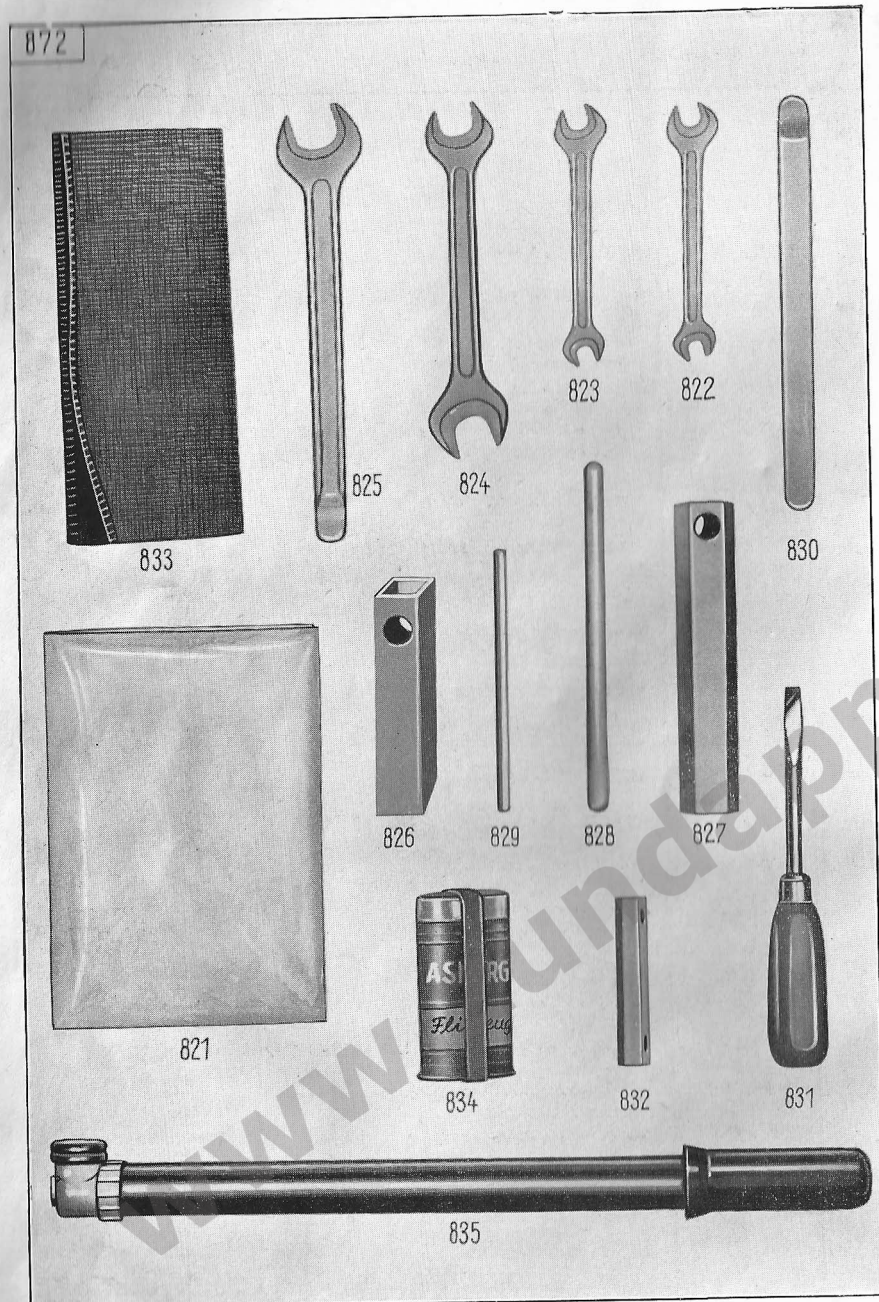

Illustration 30, Group W: a) Tools

| Key No. | Spare Part No. | Description | Quantity | Remarks |
|--------------|----------------|--|----------|----------------------------------|
| Tools | | | | |
| — | 6890 k 47 | set of tools | 1 | |
| 821 | 6040 z 273 | bag for tools | 1 | |
| 822 | — | double wrench 7 x 9 mm DIN 895 | 1 | |
| 823 | — | double wrench 8 x 10 mm DIN 895 | 1 | |
| 824 | — | double wrench 14 x 17 mm DIN 895 | 1 | |
| 825 | 2011 k 104 | single wrench 19 mm with tyre lever | 1 | |
| 826 | 2021 z 64 | square socket wrench | 1 | |
| 827 | 2021 z 61 | socket wrench (spark plug) | 1 | |
| 828 | 1671 z 02 | mandrel 10 mm ϕ | 1 | |
| 829 | 2001 z 15 | mandrel 7 mm ϕ | 1 | |
| 830 | 2001 z 01 | tyre lever | 1 | |
| 831 | 2009 z 01 | screw driver | 1 | |
| — | 2000 z 24 | screw driver | 1 | |
| 832 | 2021 z 23 | socket wrench (for carburettor) | 1 | |
| 833 | 2208 k 12 | cleaning cloth | 1 | |
| 834 | 6040 k 269 | box with repairing material for rubber parts | 1 | } may be obtained at local shops |
| — | 1596 z 401 | sleeve (to box with repair material) | 1 | |
| — | 6040 z 279 | bag (to box with repair material) | 1 | |
| 835 | 6040 k 255 | air pump, without hose | 1 | |
| — | 1596 z 291 | sleeve (for air pump) | 1 | |

Illustration 31, Group W: b) Toolbox

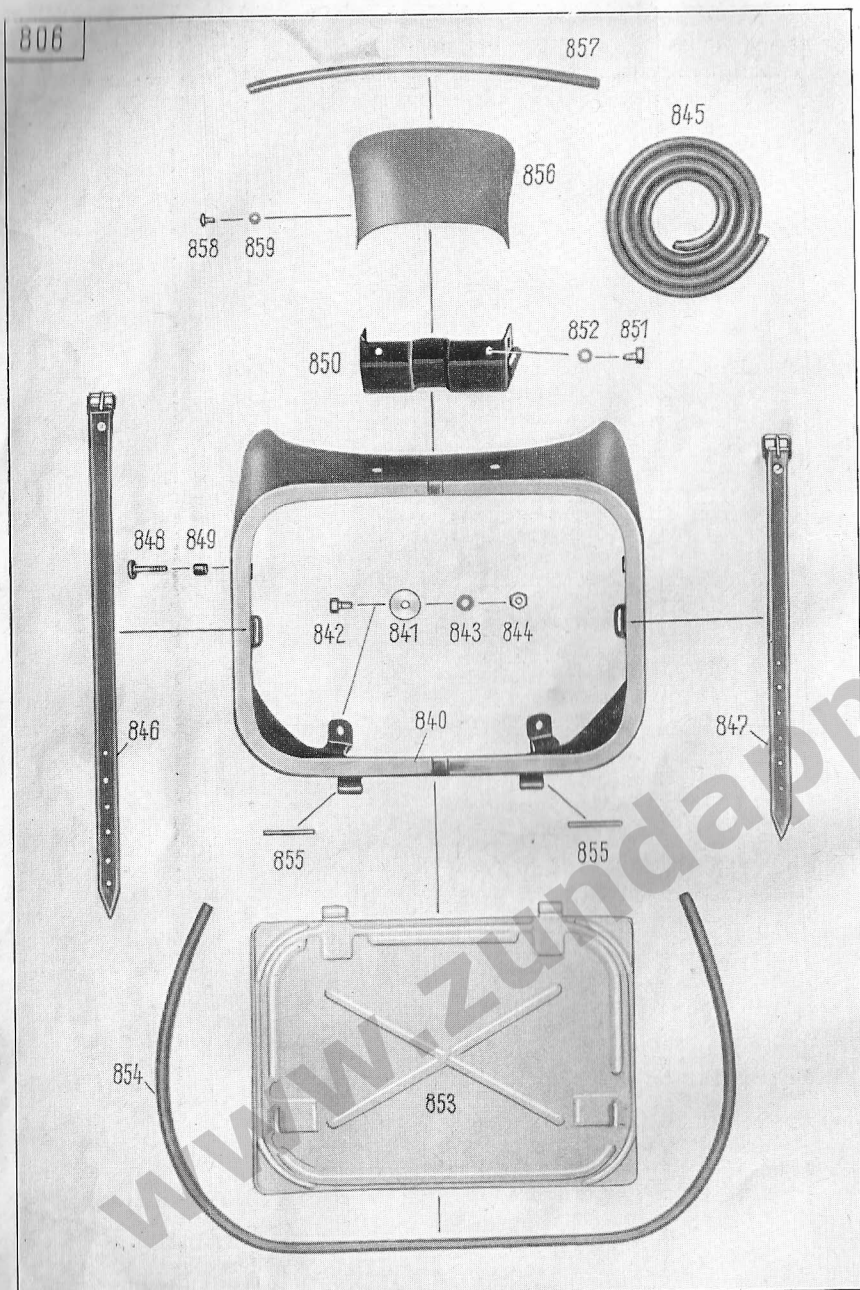

Illustration 31, Group W: b) Toolbox

| Key No. | Spare Part No. | Description | Quantity | Remarks |
|----------------|----------------|---|----------|-----------------|
| Toolbox | | | | |
| 840 | 2190 z 68 | toolbox | 1 | indicate colour |
| 841 | 1301 z 1019 | washer | 4 | |
| 842 | — | hex. head bolt M 6 x 12 DIN 933 k (to fix toolbox to rear body) | 4 | |
| 843 | — | lock washer B 6 DIN 137 k | 4 | |
| 844 | — | hex. nut M 6 DIN 934 k | 1 | |
| 845 | 1396 z 259 | rubber cord (1110 mm length) | 1 | |
| 846 | 1390 z 122 | strap with buckle (for tools) | 1 | |
| 847 | 1390 z 118 | strap with buckle (for rubber repair material) | 1 | |
| 848 | 1541 z 319 | slotted screw | 2 | |
| 849 | 176 z 48 | rubber bushing | 2 | |
| 850 | 2051 z 606 | bracket (for taillight) | 1 | |
| 851 | — | hex. head bolt M 6 x 6 DIN 933 k (to fasten bracket to toolbox) | 2 | |
| 852 | — | lock washer B 6 DIN 137 k | 2 | |
| 853 | 1470 z 13 | cover for toolbox | 1 | |
| 854 | 1396 z 258 | rubber cord (850 mm length) | 1 | |
| 855 | — | pin A 4 h 11 x 38 DIN 7341 Ms (to fasten cover to toolbox) | 2 | |
| 856 | 651 z 293 | cover plate (to taillight) | 1 | indicate colour |
| 857 | 1396 z 260 | rubber cord | 1 | |
| 858 | — | button head screw AM 4 x 5 DIN 86 crp (to fasten cover plate) | 2 | |
| 859 | — | lock washer A 4 DIN 137 k | 2 | |



ZUNDAPP-WERKE GMBH • MÜNCHEN 8
ANZINGER STRASSE 1-3 • RUF 443221