



SPARE PARTS LIST

ZÜNDAPP-SCOOTER

R 201 BELLA

with electric starter

Published in June 1956



SPARE PARTS LIST

ZÜNDAPP-SCOOTER

R 201 BELLA

with electric starter

beginning with FRAME No. R 80001

Published in June 1956

Printed in Germany

Contents

| | Page | Illustration |
|--|------|--------------|
| Introduction | 5 | — |
| Group M: a) Engine (assembly) | 9 | 1 |
| b) Housing and cylinder | | |
| Crankcase | 11 | 2 |
| Crankcase cover | 15 | 3 |
| Cylinder and cylinder head | 17 | 4 |
| c) Drive mechanism | | |
| Crankshaft, connecting rod, piston | 19 | 5 |
| f) Carburettor | 21 | 6 |
| Intake silencer and air cleaner | 25 | 7 |
| g) Clutch, clutch operating mechanism | 27 | 8 |
| Group G: c) Shafts and gears | | |
| Selector shaft | 29 | 9 |
| Layshaft | 31 | 9 |
| d) Footshift mechanism | 33 | 10 |
| Group R: a) Frame | 37 | 11 |
| Front engine carrier, centre stand | 39 | 12 |
| Rear engine carrier with swinging fork | 41 | 13 |
| b) Foot boards and folding grids | 45 | 14 |
| d) Mudguards | | |
| Front mudguard | 47 | 15 |
| Rear mudguard and chaincase | 49 | 16 |
| e) Body | | |
| Front shield | 53 | 17 |
| Front cover and dashboard | | |
| with cover | 55 | 18 |
| Rear body | 57 | 19 |
| Dual seat | 61 | 20 |
| f) Fuel tank and fuel pipes | 63 | 21 |
| h) Exhaust set | 65 | 22 |
| i) Front fork | 67 | 23 |
| Front swinging arm suspension | 67 | 23a |
| k) Handlebar and hand levers | | |
| with cables | 71 | 24 |
| Group B: a) Brakes | | |
| Handbrake | 75 | 25 |
| Footbrake | 77 | 26 |
| b) Wheels | 81 | 27 |
| Group E: a) Electrical equipment | | |
| Headlight, battery, dashboard, | | |
| taillight, horn, conducts | 83 | 28 |
| Starter generator | 89 | 29 |
| Group W: Tools | 91 | 30 |

INTRODUCTION

Please take note that only **Genuine Zündapp Spares** will be the safeguard for security, claims under guarantee, and will prevent many a damage and loss.

Therefore, do not use parts of another origin but demand only **Genuine Zündapp Spares** from your Zündapp dealer, for by fitting imitated parts any claim under guarantee will automatically become void.

In order to avoid errors, queries, and incorrect deliveries, please quote with all orders for spare parts:

1. **Description and number of the spare part wanted**
in accordance with this list,
2. **Frame number**
stamped into the rating plate,
3. **Modifications made on the vehicle**
by exchanging spare parts or groups.

If these data cannot be given it will be necessary to send in a pattern labelled with the sender's name and address. These patterns will be returned to the sender only upon request.

Model Order

Re. Frame No. R 81 325

| | |
|----------------|----------------|
| 1 crankshaft | No. 1950 k 206 |
| 1 cylinder | No. 2162 z 207 |
| 1 piston | No. 883 z 153 |
| 2 piston rings | No. 1262 z 102 |

Deliveries of spare parts are only made through our respective representatives.

All illustrations and data in this list are not binding. We reserve the right for alterations without previous notice.

ZÜNDAPP-WERKE G.M.B.H., NÜRNBERG-MÜNCHEN
NÜRNBERG WORKS

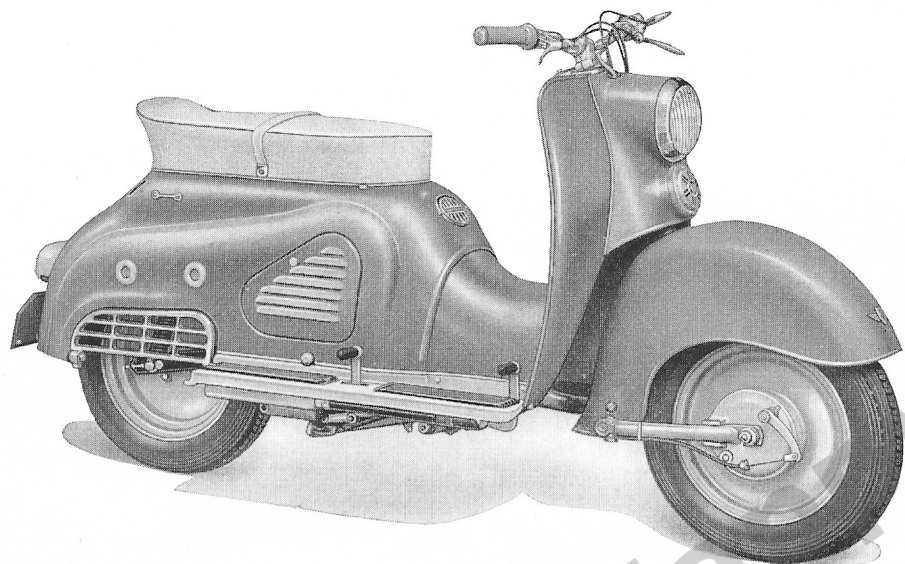

R 201, right-hand view
beginning with Frame No. R 80 001

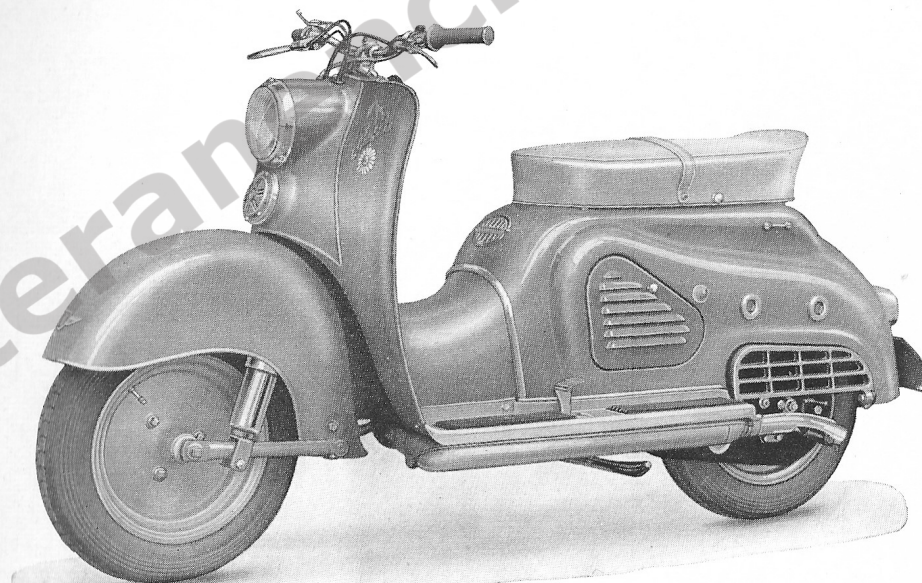

R 201, left-hand view
beginning with Frame No. R 80 001

Illustration 1, Group M: a) Engine (Assembly)

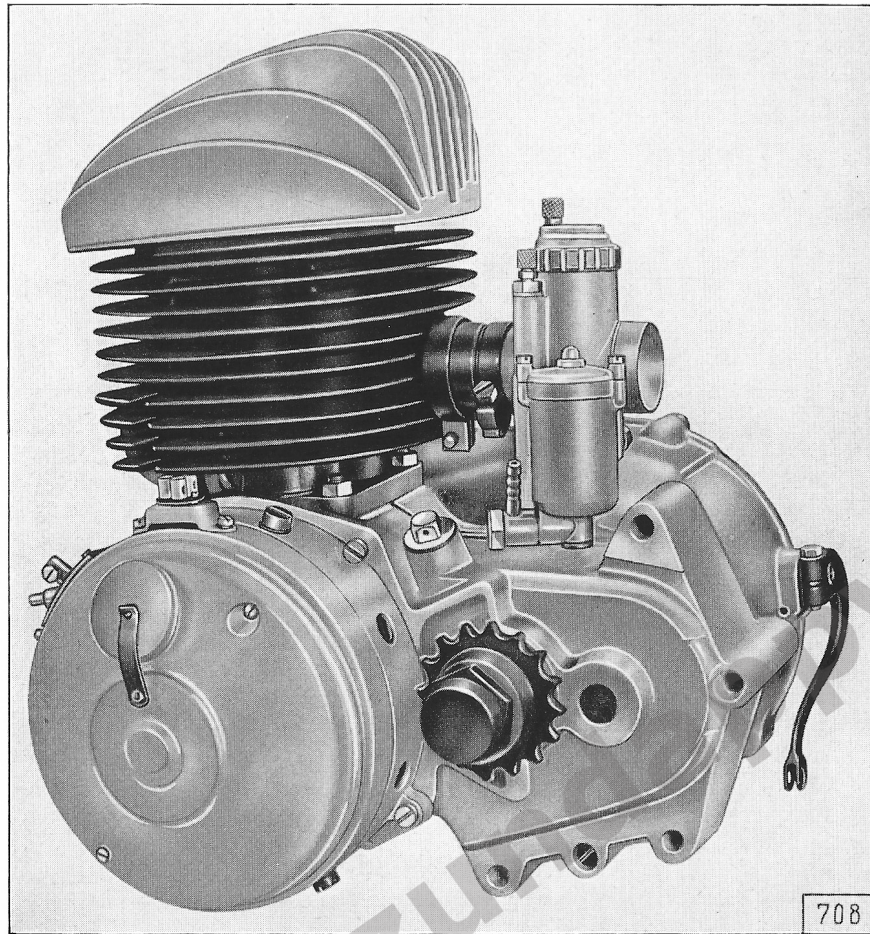

Illustration 1, Group M: a) Engine (Assembly)

| Key No. | Spare Part No. | Description | No. of Pieces | Remarks |
|---------|----------------|---|---------------|---------|
| — | 6590 k 245 | <p style="text-align: center;">Engine</p> Engine complete with starter generator and carburettor | 1 | |

Illustration 2, Group M: b) Housing and Cylinder, Crankcase

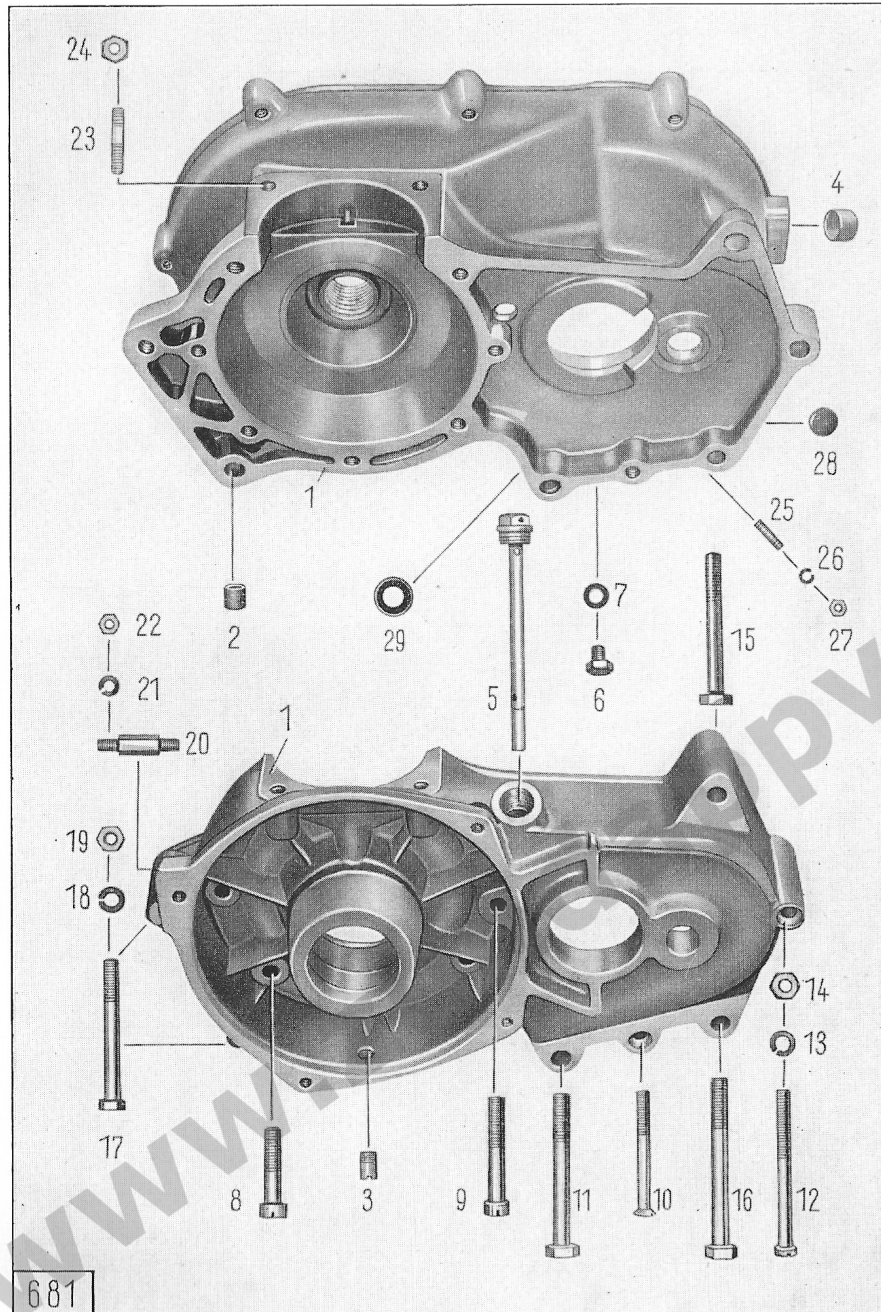

Illustration 2, Group M: b) Housing and Cylinder, Crankcase

| Key No. | Spare Part No. | Description | No. of Pieces | Remarks |
|------------------|----------------|--|---------------|---------|
| Crankcase | | | | |
| 1 | 510 k 226 | crankcase complete | 1 | |
| 2 | 181 z 18 | bushing (between left and right half of crankcase) | 2 | |
| 3 | 1331 z 839 | gas escape pipe | 1 | |
| 4 | 184 z 328 | bearing bushing (for clutch pressure bar) | 1 | |
| 5 | 1550 z 109 | oil dip stick (for gearbox) | 1 | |
| 6 | — | hex. screw M 8 × 10 DIN 933 (for oil draining) | 3 | |
| 7 | — | gasket C 8 × 14 DIN 7603 | 3 | |
| 8 | — | cylindrical screw M 8 × 40 DIN 912 k (to fasten left to right half of crankcase) | 6 | |
| 9 | — | cylindrical screw M 8 × 55 DIN 912 k (to fasten left to right half of crankcase) | 1 | |
| 10 | — | screw, countersunk raised head M 8 × 65 DIN 91 k (to fasten left to right half of crankcase) | 1 | |
| 11 | — | hex. screw M 10 × 80 DIN 931 k (to fasten left to right half of crankcase) | 1 | |
| — | — | spring washer B 10 DIN 137 k | 1 | |
| — | — | hex. nut M 10 DIN 934 k | 1 | |
| 12 | — | cylindrical screw CM 8 × 85 DIN 84 k (to fasten left to right half of crankcase as well as to rear engine carrier) | 1 | |
| 13 | — | spring washer A 8 DIN 127 k | 1 | |
| 14 | — | hex. nut M 8 DIN 934 k | 1 | |

Illustration 2, Group M: b) Housing and Cylinder, Crankcase

| Key No. | Spare Part No. | Description | No. of Pieces | Remarks |
|---------|----------------|--|---------------|---------|
| 15 | — | hex. screw M 10 × 75 DIN 931 k (to fasten crankcase to rear engine carrier) | 1 | |
| 16 | — | hex. screw M 10 × 90 DIN 931 k (to fasten crankcase to rear engine carrier) | 1 | |
| — | — | spring washer A 10 DIN 127 k | 2 | |
| — | — | hex. nut M 10 DIN 934 k | 2 | |
| 17 | — | hex. screw M 8 × 75 DIN 931 k (to fasten crankcase to front engine suspending sheets) | 2 | |
| 18 | — | spring washer A 8 DIN 127 k | 2 | |
| 19 | — | hex. nut M 8 DIN 934 k | 2 | |
| 20 | 121 z 1102 | thread bolt (to fasten ignition coil to crankcase) | 2 | |
| 21 | — | spring washer A 6 DIN 127 k | 2 | |
| 22 | — | hex. nut M 6 DIN 934 k | 2 | |
| 23 | 1561 z 010 | stud (for fixing cylinder) | 4 | |
| 24 | — | hex. nut M 8 DIN 934 k | 4 | |
| 25 | 1561 z 107 | stud (for fixing gear selector support) | 4 | |
| 26 | — | spring washer A 5 DIN 127 k | 4 | |
| 27 | — | hex. nut M 5 DIN 934 k | 4 | |
| 28 | — | sealing washer 16 DIN 470 (pertaining to right half of crankcase) . . | 1 | |
| 29 | — | radial gasket (oil seal) B 14 × 24 × 7 DIN 6503 (pertaining to footshift shaft) | 1 | |

Illustration 3, Group M: b) Housing and Cylinder, Crankcase Cover

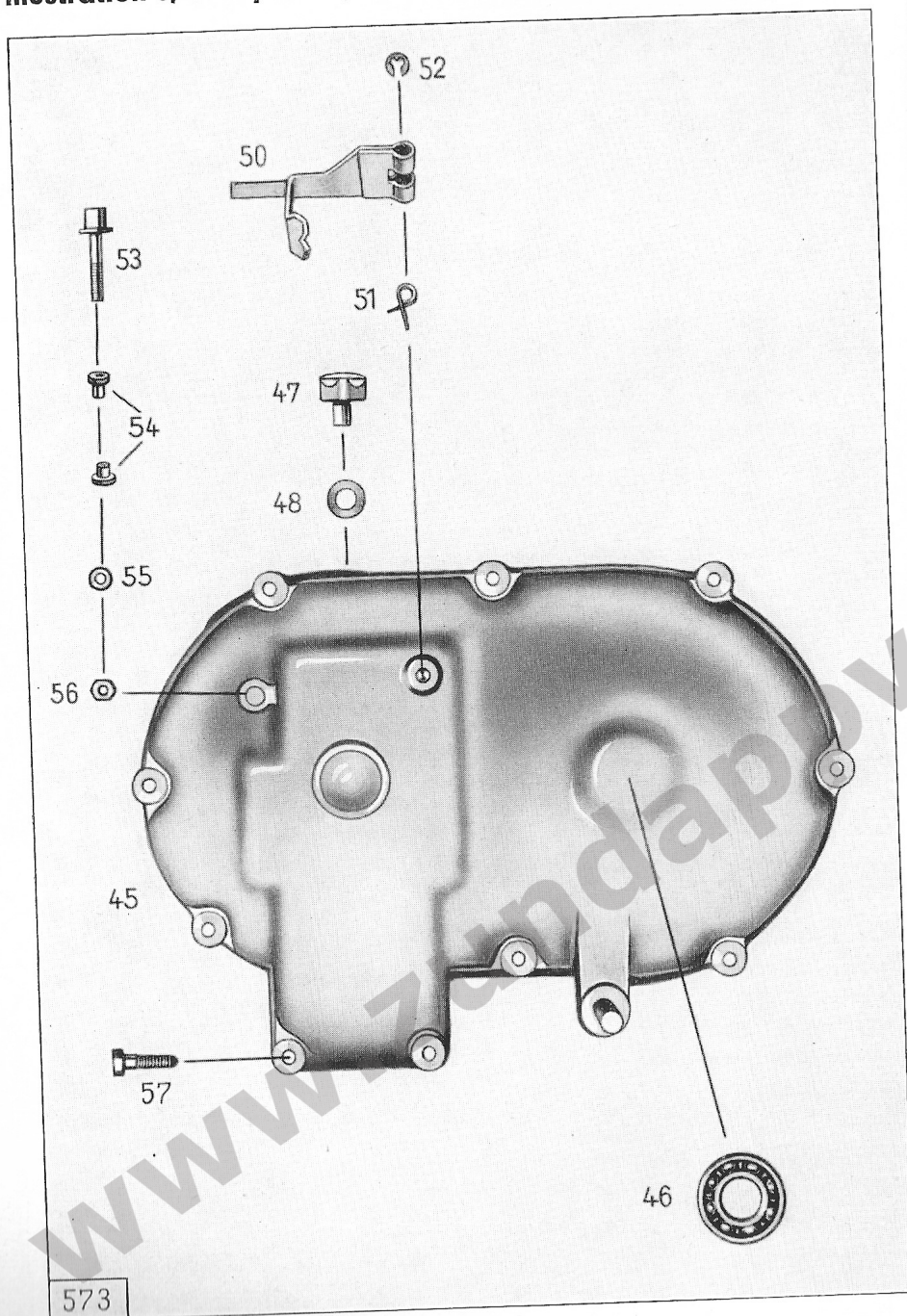

Illustration 3, Group M: b) Housing and Cylinder, Crankcase Cover

| Key No. | Spare Part No. | Description | No. of Pieces | Remarks |
|------------------------|----------------|--|---------------|---------------------------|
| Crankcase Cover | | | | |
| 45 | 260 z 36 | crankcase cover | 1 | up to Frame 88 991 |
| — | 260 z 40 | crankcase cover | 1 | } from F. 88 992 |
| — | 121 z 1122 | bolt | 1 | |
| — | — | spring washer A 8 DIN 137 | 1 | |
| — | — | hex. nut M 8 DIN 934 k | 1 | |
| 46 | — | ball bearing 6203 DIN 625 | 1 | } as re- quir- ed |
| 47 | 1121 z 32 | supporting bolt | 1 | |
| 48 | 1301 z 52 | compensating shim | } | for supporting bolt |
| — | 1301 z 616 | compensating shim | | |
| 50 | 670 z 205 | contact breaker arm (for idle check light) | 1 | |
| 51 | 321 z 322 | ratchet spring | 1 | |
| 52 | — | C-washer 3,2 DIN 6799 | 1 | |
| 53 | 131 z 515 | bolt | 1 | |
| 54 | 176 z 29 | bushing | 2 | |
| 55 | — | washer 5,3 DIN 125 k | 2 | |
| 56 | — | hex. nut M 5 DIN 934 k | 2 | |
| — | — | hex. screw M 6 × 22 DIN 931 k (to fasten crankcase cover to crankcase) | 8 | |
| 57 | — | hex. screw M 6 × 25 DIN 931 k (to fasten crankcase cover to crankcase) | 2 | |

Illustration 4, Group M: b) Housing and Cylinder, Cylinder and Cylinder Head

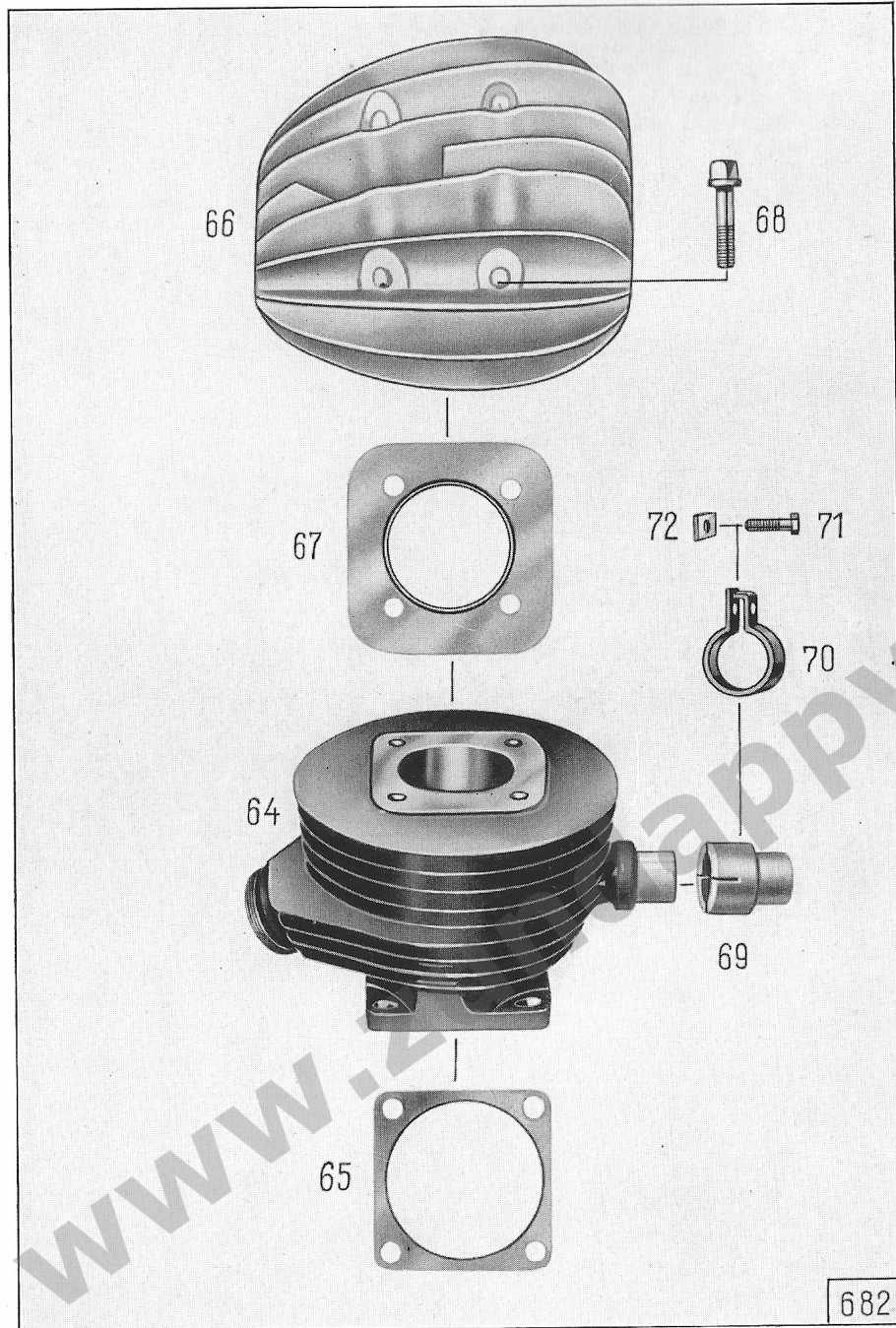
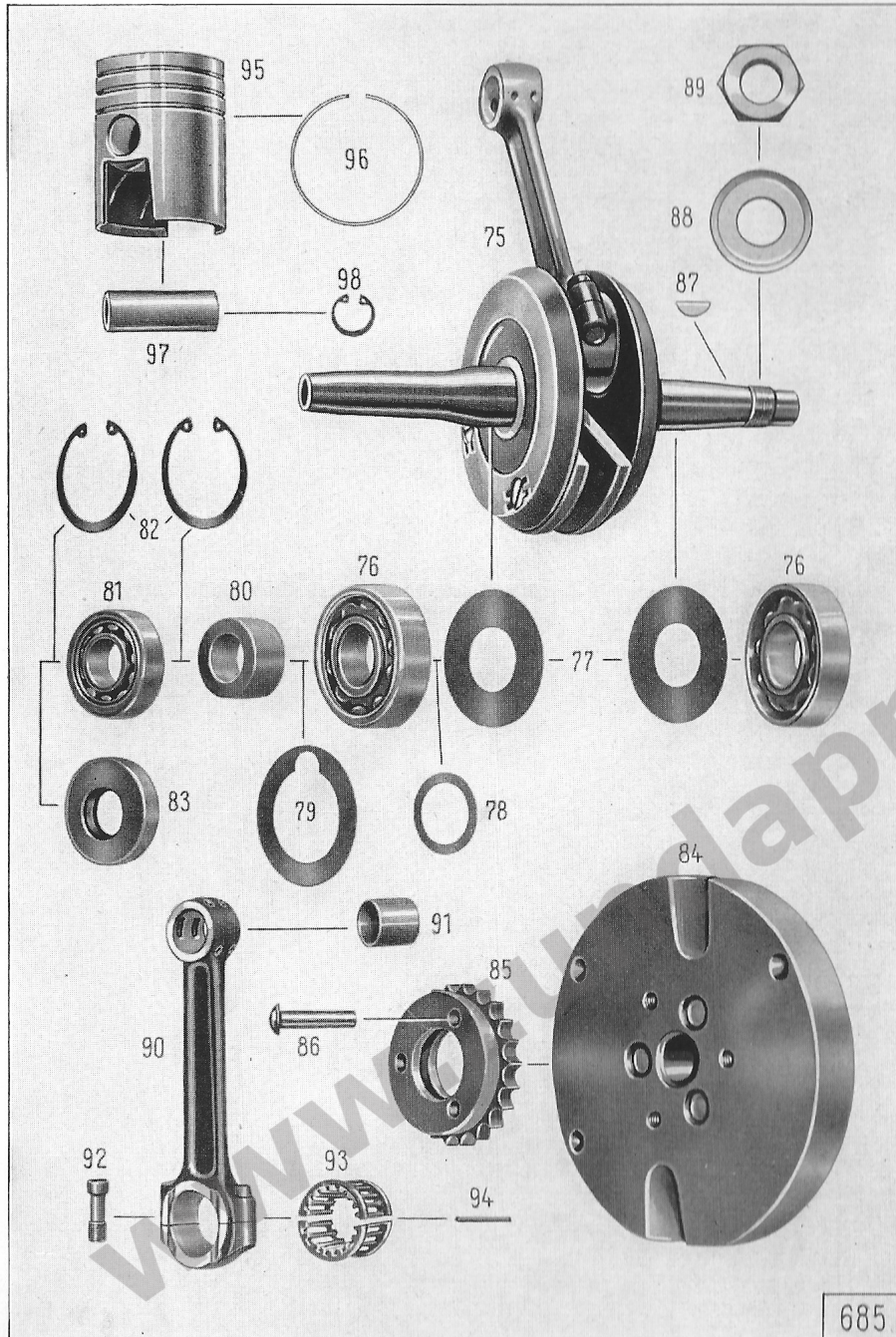

Illustration 4, Group M: b) Housing and Cylinder, Cylinder and Cylinder Head

| Key No. | Spare Part No. | Description | No. of Pieces | Remarks |
|-----------------|----------------|--|---------------|---------|
| Cylinder | | | | |
| 64 | 2162 z 207 | cylinder | 1 | |
| 65 | 468 z 313 | cylinder flange gasket | 1 | |
| 66 | 273 z 156 | cylinder head | 1 | |
| — | 174 z 6 | tapped insert (spark plug) | 1 | |
| 67 | 461 z 6 | cylinder head gasket | 1 | |
| 68 | 1551 z 016 | square screw (to fasten cylinder head) | 4 | |
| 69 | 177 z 105 | insulating bushing | 1 | |
| 70 | 1441 z 160 | clamp | 1 | |
| 71 | — | hex. screw M 6 × 20 Sz DIN 933 k (to clamp) | 1 | |
| 72 | 1001 z 217 | square nut | 1 | |

Illustration 5, Group M: c) Drive Mechanism, Crankshaft, Connecting Rod, and Piston



685

Illustration 5, Group M: c) Drive Mechanism, Crankshaft, Connecting Rod, and Piston

| Key No. | Spare Part No. | Description | No. of Pieces | Remarks |
|-----------------------|----------------|---|---|------------------------------------|
| Crankshaft | | | | |
| 75 | 1950 k 206 | crankshaft with connecting rod .. | 1 | } betw. crank web and ball-bearing |
| 76 | — | ball-bearing M 25 DIN 615 | 2 | |
| 77 | 1281 z 382 | covering washer | 2 | |
| 78 | 1301 z 1003 | spacer shim 27,2 × 36 × 0,05 | } as required | |
| — | 1301 z 1004 | spacer shim 27,2 × 36 × 0,1 | | |
| — | 1301 z 1005 | spacer shim 27,2 × 36 × 0,15 | | |
| 79 | 1301 z 132 | spacer shim 41 × 61,5 × 0,1 | | |
| — | 1301 z 133 | spacer shim 41 × 61,5 × 0,2 | | |
| — | 1301 z 134 | spacer shim 41 × 61,5 × 0,3 | | |
| — | 1301 z 135 | spacer shim 41 × 61,5 × 0,5 | | |
| — | 1301 z 1012 | spacer shim 41 × 61,5 × 0,15 | } betw. ball-bearing and crankcase, left-hand | |
| 80 | 181 z 341 | bushing (on crankshaft) | | 1 |
| 81 | — | roller bearing NJL 20 DIN 5412 | 1 | |
| 82 | — | circlip 47 × 1,75 DIN 472 | 2 | |
| 83 | — | radial gasket (oil seal) B 20 × 47 × 10 DIN 6503 | 1 | |
| 84 | 1310 z 60 | flywheel with sprocket | 1 | |
| 85 | 2101 z 155 | sprocket 27 teeth (to flywheel) | 1 | |
| 86 | — | rivet, button head, 7 × 40 DIN 660 | 3 | |
| 87 | — | key 4 × 6,5 DIN 6888 | 1 | |
| 88 | 1291 z 64 | lock washer | 1 | |
| 89 | 1001 z 20 | hex. nut | 1 | |
| Connecting Rod | | | | |
| 90 | 1160 k 151 | connecting rod | 1 | |
| 91 | 184 z 523 | gudgeon pin bushing | 1 | |
| 92 | 1571 z 1 | connecting rod screw | 2 | |
| 93 | 1874 z 1 | cage ring | 1 | |
| 94 | 1871 z 1 | bearing needle | 18 | |
| Piston | | | | |
| 95 | 883 z 153 | piston 64,0 φ (standard) | 1 | |
| — | 2473 k 51-0 | piston 64,5 φ 1st oversize | 1 | |
| — | 2473 k 52-0 | piston 65,0 φ 2nd oversize | 1 | |
| — | 2473 k 53-0 | piston 65,5 φ 3rd oversize | 1 | |
| — | 2473 k 54-0 | piston 66,0 φ 4th oversize | 1 | |
| 96 | 1262 z 102 | piston ring 64,0 mm φ (standard) .. | 3 | |
| — | 2442 k 45-0 | piston ring 64,5 mm φ 1st oversize | 3 | |
| — | 2442 k 46-0 | piston ring 65,0 mm φ 2nd oversize | 3 | |
| — | 2442 k 47-0 | piston ring 65,5 mm φ 3rd oversize | 3 | |
| — | 2442 k 48-0 | piston ring 66,0 mm φ 4th oversize | 3 | |
| 97 | 121 z 1066 | gudgeon pin | 1 | |
| 98 | — | circlip 18 × 1 DIN 472 | 2 | |

Illustration 6, Group M: f) Carburettor

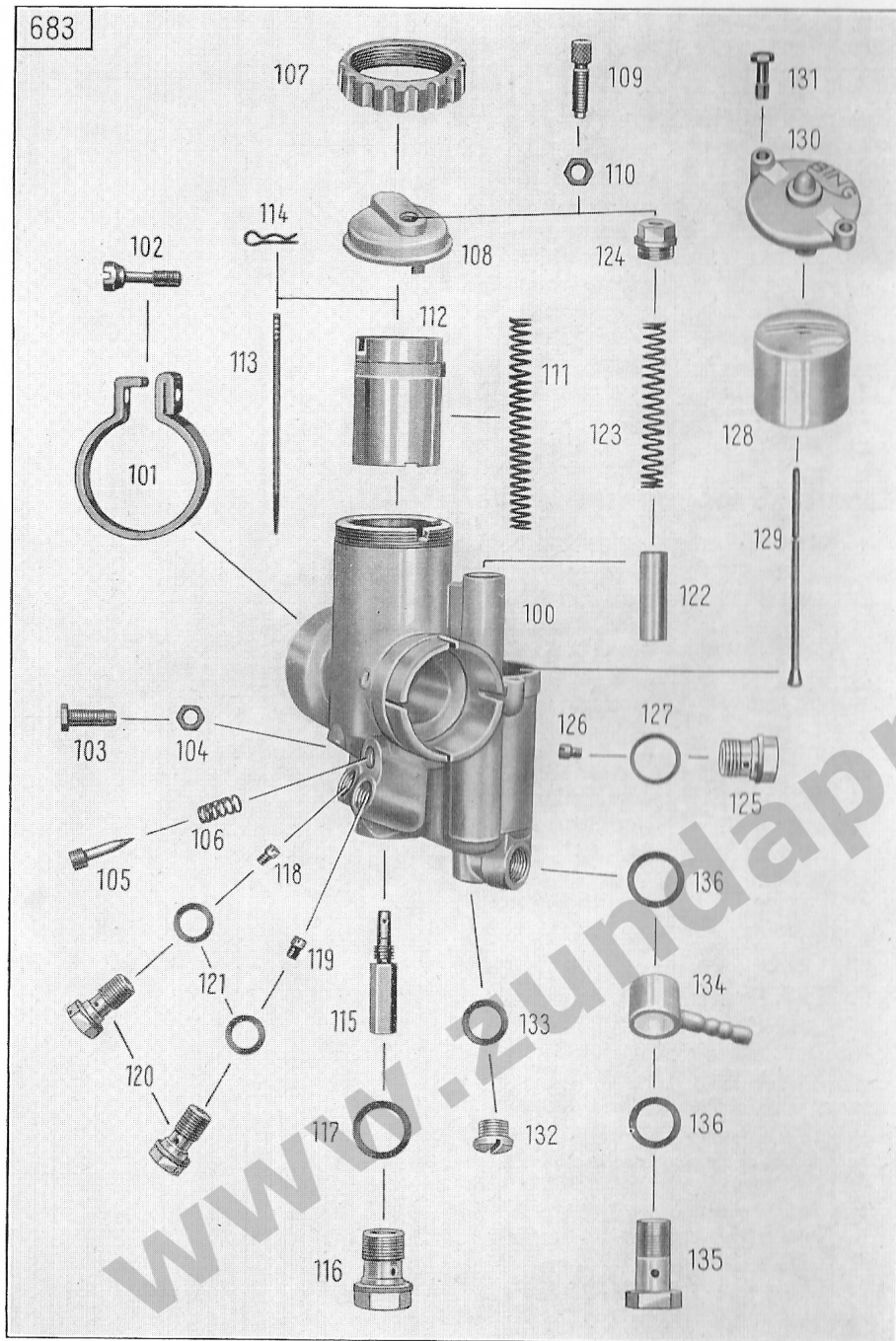

Illustration 6, Group M: f) Carburettor

| Key No. | Spare Part No. | Description | No. of Pieces | Remarks |
|---------|----------------|---|---------------|------------|
| | | Carburettor | | |
| — | 6430 z 79 | oblique-jet carburettor with starting device (model Bing 1/22/89) | 1 | s. page 23 |
| 100 | 2403 k 96-0 | carburettor housing | 1 | |
| 101 | 2401 k 78-2 | clamping ring | 1 | |
| 102 | 2401 k 2-2 | screw (to clamping ring) | 1 | |
| 103 | 2401 k 3-2 | idle running adjusting screw | 1 | |
| 104 | 2401 k 6-2 | nut (for idle running adjusting screw) | 1 | |
| 105 | 2401 k 70-2 | idle air screw | 1 | |
| 106 | 2401 k 69-2 | spring (to idle air screw) | 1 | |
| 107 | 2403 k 51-0 | nut (to seal cover) | 1 | |
| 108 | 2403 k 97-0 | cover plate | 1 | |
| 109 | 2401 k 5-4 | adjusting screw for throttle cable | 1 | |
| 110 | 2401 k 6-2 | nut (to throttle cable adjusting screw) | 1 | |
| 111 | 2401 k 52-2 | slide spring | 1 | |
| 112 | 2403 k 98-0 | gas slide (No. 13) | 1 | |
| 113 | 2401 k 89-0 | jet needle | 1 | |
| 114 | 2401 k 80-2 | clip (for jet needle) | 1 | |
| 115 | 2404 k 32-0 | needle jet (please quote No. stamped on it when ordering) | 1 | |
| 116 | 2403 k 55-0 | end screw | 1 | |
| 117 | 2407 k 7-0 | gasket (for end screw) | 1 | |
| 118 | 2404 k 23-0 | jet (main jet, size 110) | 1 | |
| 119 | 2404 k 23-0 | jet (idling jet, size 45) | 1 | |
| 120 | 2401 k 81-6 | jet block | 2 | |
| 121 | 2407 k 14-0 | gasket (to jet block) | 2 | |
| 122 | 2403 k 99-0 | starter slide | 1 | |
| 123 | 2401 k 90-2 | pressure spring | 1 | |
| — | 2401 k 96 | lock washer | 1 | |
| 124 | 2401 k 91-0 | lock screw | 1 | |

Illustration 6, Group M: f) Carburettor

| Key No. | Spare Part No. | Description | No. of Pieces | Remarks |
|--|----------------|---|---------------|---------|
| 109 | 2401 k 5-4 | adjusting screw for throttle cable | 1 | |
| 110 | 2401 k 6-2 | nut (to throttle cable adjusting screw) | 1 | |
| 125 | 2401 k 92-0 | end screw | 1 | |
| 126 | 2404 k 23-0 | jet (starter jet, size 85) | 1 | |
| 127 | 2407 k 17-0 | gasket (to end screw) | 1 | |
| 128 | 2404 k 3-0 | float | 1 | |
| 129 | 2401 k 93-0 | float needle | 1 | |
| 130 | 2403 k 100-0 | float chamber cover | 1 | |
| 131 | 2401 k 61-2 | set screw (to cover) | 2 | |
| 132 | 2401 k 94-0 | lock screw | 1 | |
| 133 | 2407 k 18-0 | gasket (to lock screw) | 1 | |
| 134 | 2403 k 101-0 | swivel type pipe connector | 1 | |
| 135 | 2401 k 95-0 | set screw | 1 | |
| 136 | 2407 k 19-0 | gasket (to set screw) | 2 | |
| <p>The oblique-jet carburettor with starting device 6430 z 77 (model Bing 1/22/79) may be converted to 6430 z 79 (model Bing 1/22/89) by insertion of the following parts:</p> | | | | |
| — | 2403 k 98-0 | gas slide (No. 13) | 1 | |
| — | 2404 k 23-0 | jet (idling jet, size 45) | 1 | |
| — | 2404 k 23-0 | jet (starter jet, size 85) | 1 | |

Illustration 7, Group M: f) Carburettor, Intake Silencer and Air Cleaner

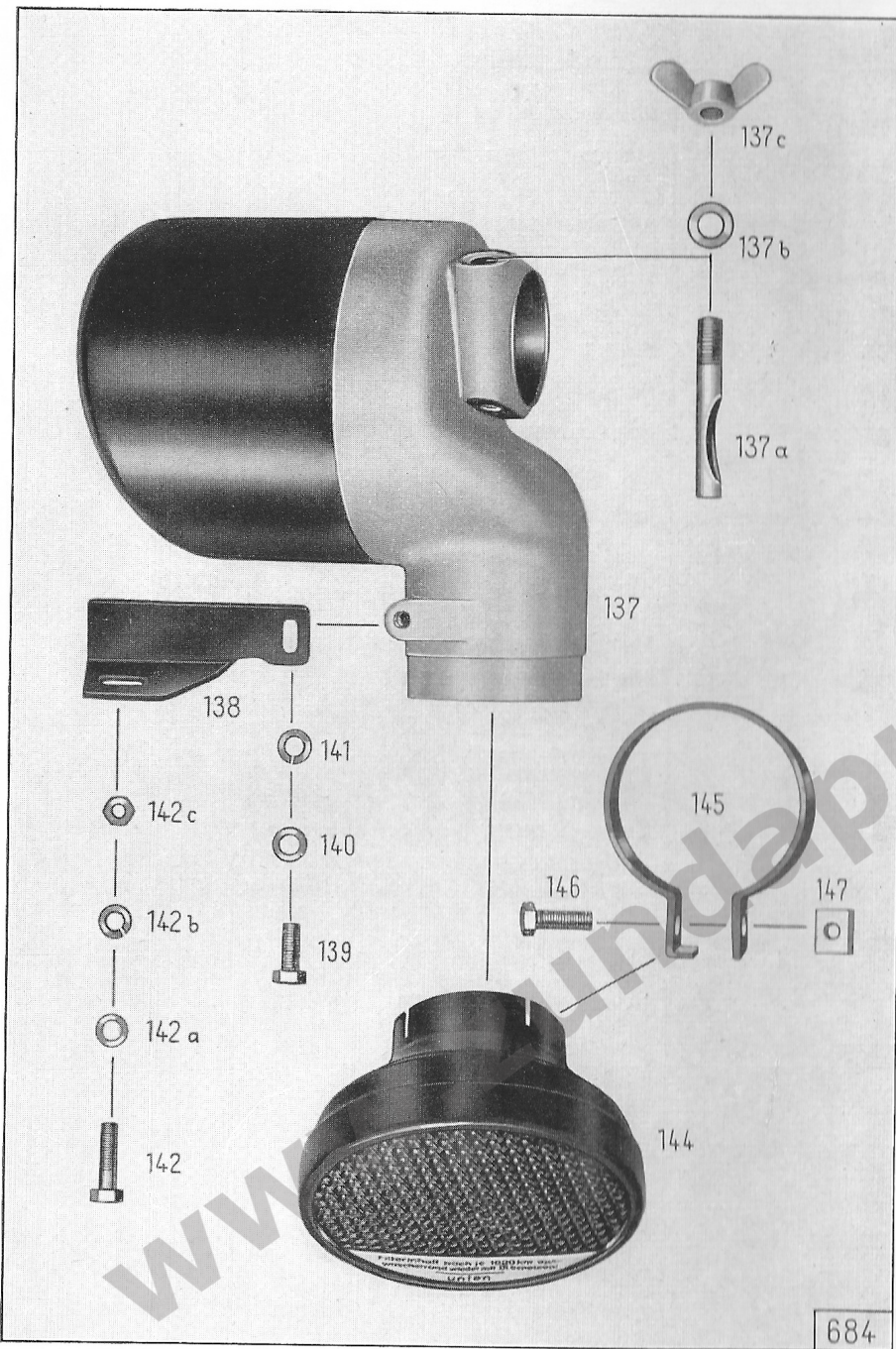

684

Illustration 7, Group M: f) Carburettor, Intake Silencer and Air Cleaner

| Key No. | Spare Part No. | Description | No. of Pieces | Remarks |
|------------------------|----------------|---|---------------|---------|
| Intake Silencer | | | | |
| 137 | 6350 z 116 | intake silencer | 1 | |
| 137a | 121 z 1104-3 | clamping bolt (to fasten intake silencer to carburettor) | 1 | |
| 137b | — | spring washer A 8 DIN 137 k | 2 | |
| 137c | — | wing nut M 8 DIN 315 k | 1 | |
| 138 | 2051 z 555-2 | angle bracket | 1 | |
| 139 | — | hex. screw M 6 × 15 DIN 933 k (to fasten angle bracket to intake silencer) | 1 | |
| 140 | — | washer 6,4 DIN 125 k | 1 | |
| 141 | — | spring washer A 6 DIN 127 k | 1 | |
| 142 | — | hex. screw M 6 × 20 DIN 933 k (to fasten angle bracket to rear engine carrier) | 1 | |
| 142a | — | washer 6,4 DIN 125 k | 1 | |
| 142b | — | spring washer A 6 DIN 127 k | 1 | |
| 142c | — | hex. nut M 6 DIN 934 k | 1 | |
| Air Cleaner | | | | |
| 144 | 6410 k 210 | air filter | 1 | |
| 145 | 1441 k 306-2 | clamp | 1 | |
| 146 | — | hex. screw M 6 x 20 DIN 933 k (to clamp) | 1 | |
| 147 | 1001 z 217 | square nut | 1 | |

Illustration 8, Group M: g) Clutch, Clutch, Clutch Operating Mechanism

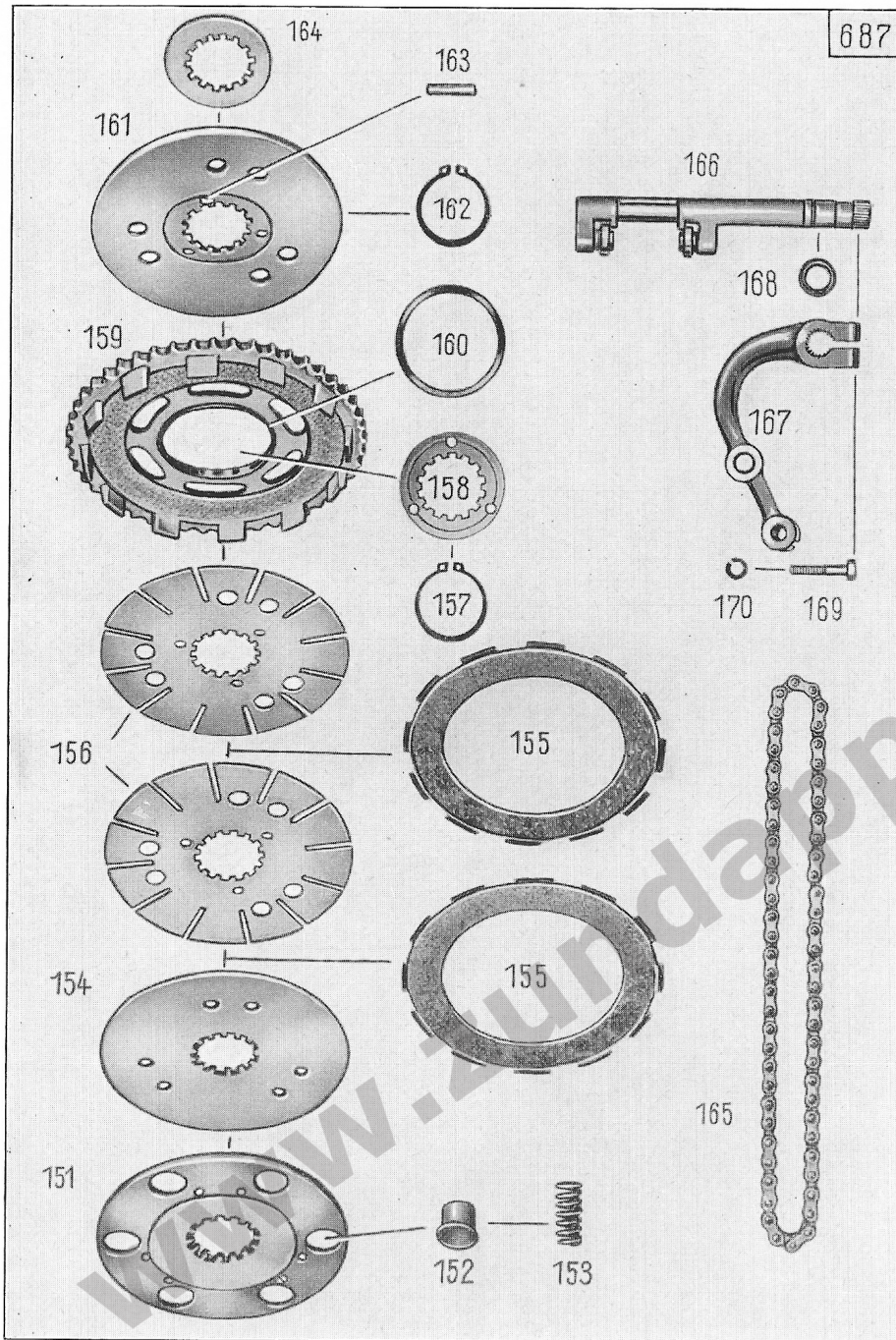

Illustration 8, Group M: g) Clutch, Clutch, Clutch Operating Mechanism

| Key No. | Spare Part No. | Description | No. of Pieces | Remarks |
|-----------------------------------|----------------|---|---------------|---------------------------|
| Clutch | | | | |
| 151 | 921 z 69 | spring plate | 1 | |
| 152 | 781 z 273 | spring cap (in spring plate) | 6 | |
| 153 | 321 z 564 | clutch spring | 6 | |
| 154 | 921 z 67 | clutch pressure plate | 1 | |
| 155 | 920 z 52 | clutch disk with lining | 2 | |
| 156 | 921 z 68 | clutch disk | 2 | |
| 157 | — | circlip 35 x 1,5 DIN 471 | 1 | with ground side surfaces |
| 158 | 1231 z 212 | spacer ring | 1 | |
| 159 | 2100 z 165 | clutch sprocket with bushing, 48 teeth | 1 | |
| 160 | 184 z 317 | bushing (in clutch sprocket) | 1 | |
| 161 | 921 z 203 | clutch plate | 1 | |
| 162 | — | circlip 35 x 1,5 DIN 471 | 1 | with ground side surfaces |
| 163 | 1691 z 113 | push rod | 3 | |
| 164 | 1231 z 213 | pressure ring | 1 | |
| 165 | — | roller chain 64 links, endless A 9,5 x 9,5 DIN 73232 | 1 | |
| Clutch operating mechanism | | | | |
| 166 | 1940 z 25 | clutch pressure bar, complete | 1 | |
| 167 | 671 z 338 | clutch lever (for clutch pressure bar) | 1 | |
| 168 | 1236 z 222 | gasket | 1 | |
| 169 | — | hex. screw M 6 x 25 DIN 931 k (to fasten clutch lever to pressure bar) .. | 1 | |
| 170 | — | spring washer A 6 DIN 127 k | 1 | |

Illustration 9, Group G: c) Shafts and Gears, Selector Shaft, Layshaft

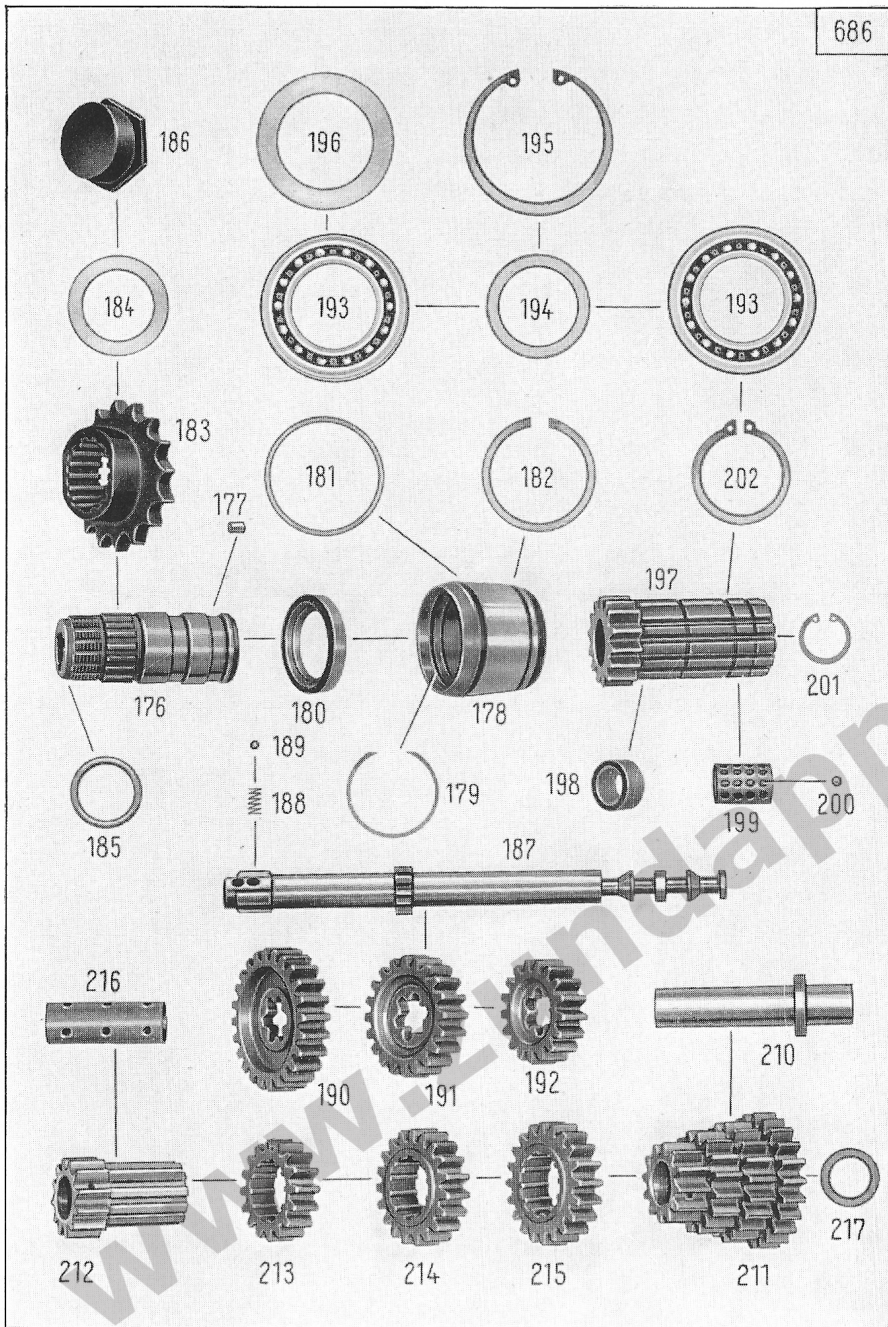

Illustration 9, Group G: c) Shafts and Gears, Selector Shaft, Layshaft

| Key No. | Spare Part No. | Description | No. of Pieces | Remarks |
|-----------------------|----------------|---|--------------------|--|
| Selector Shaft | | | | |
| 176 | 961 z 125 | final drive shaft | 1 | |
| 177 | 1871 z 07 | roller | 38 | |
| 178 | 1871 z 154 | bearing ring (to left half of crankcase) | 1 | |
| 179 | 1251 z 99 | internal circlip | 2 | } at option |
| — | 1251 z 251 | internal circlip | 2 | |
| — | 1251 z 252 | internal circlip | 2 | |
| 180 | — | radial gasket (oil seal) B 32 × 45 × 7 DIN 6503 (in bearing ring) | 1 | |
| 181 | 1301 z 603 | spacer shim 48,1 × 52,3 × 0,5 | } as re- quired | } betw. bearing ring and half of crankcase |
| — | 1301 z 604 | spacer shim 48,1 × 52,3 × 0,3 | | |
| — | 1301 z 605 | spacer shim 48,1 × 52,3 × 0,2 | | |
| 182 | 1251 z 176 | spring ring (to fasten bearing ring in half of crankcase) | 1 | |
| 183 | 2101 z 60 | sprocket 16 teeth (on final drive shaft) | 1 | |
| 184 | 1291 z 65 | lock washer | 1 | |
| 185 | 1236 z 220 | gasket | 1 | |
| 186 | 1001 z 214 | lock nut (to fasten sprocket to final drive shaft) | 1 | |
| 187 | 1921 z 701 | selector shaft | 1 | |
| 188 | 321 z 312 | pressure spring | 2 | |
| 189 | — | ball 6 mm III DIN 5401 | 3 | |
| 190 | 2131 z 303 | gear wheel 1st speed 24 teeth .. | 1 | |
| 191 | 2131 z 304 | gear wheel 2nd speed 20 teeth .. | 1 | |
| 192 | 2131 z 307 | gear wheel 3rd speed 17 teeth .. | 1 | |
| 193 | — | ball bearing 16 007 DIN 625 (to right half of crankcase) | 2 | |
| 194 | — | spacer ring 35 × 45 × 2 DIN 988 (between the ball bearings) | 1 | |
| 195 | — | circlip 62 × 2 DIN 472 | 1 | |
| 196 | 1301 z 133 | covering washer (betw. crankcase and ball bearing) | 1 | |

Illustration 9, Group G: c) Shafts and Gears, Selector Shaft, Layshaft

| Key No. | Spare Part No. | Description | No. of Pieces | Remarks |
|-----------------|----------------|---|--------------------|---|
| 197 | 960 z 101 | clutch hub (simultaneously 4th speed) | 1 | |
| 198 | 184 z 324 | bearing bushing (in clutch hub) .. | 1 | |
| 199 | 1871 z 151 | ball cage | 1 | |
| 200 | — | ball 4 mm III DIN 5401 | 40 | |
| 201 | 1251 k 259 | circlip J 23 × 1,2 | 1 | |
| 202 | — | circlip 35 x 1,5 DIN 471 (to fasten clutch hub to half of crankcase) | 1 | with ground side surfaces |
| Layshaft | | | | |
| 210 | 1940 z 206 | layshaft | 1 | |
| 211 | 2130 z 101 | gear wheel block, complete | 1 | |
| 212 | 2131 z 238 | gear wheel 1st speed 12 teeth .. | 1 | |
| 213 | 2131 z 239 | gear wheel 2nd speed 16 teeth .. | 1 | |
| 214 | 2131 z 247 | gear wheel 3rd speed 19 teeth .. | 1 | |
| 215 | 2131 z 237 | drive gear 22 teeth | 1 | |
| 216 | 184 z 316 | bushing | 1 | |
| 217 | 1301 z 177 | spacer shim 18,2 × 25,7 × 0,5 | } as re- quired | } betw. gear wheel block and right half of crankcase |
| — | 1301 z 367 | spacer shim 18,2 × 25,7 × 0,2 | | |
| — | 1301 z 368 | spacer shim 18,2 × 25,7 × 0,3 | | |

Illustration 10, Group G: d) Footshift Mechanism

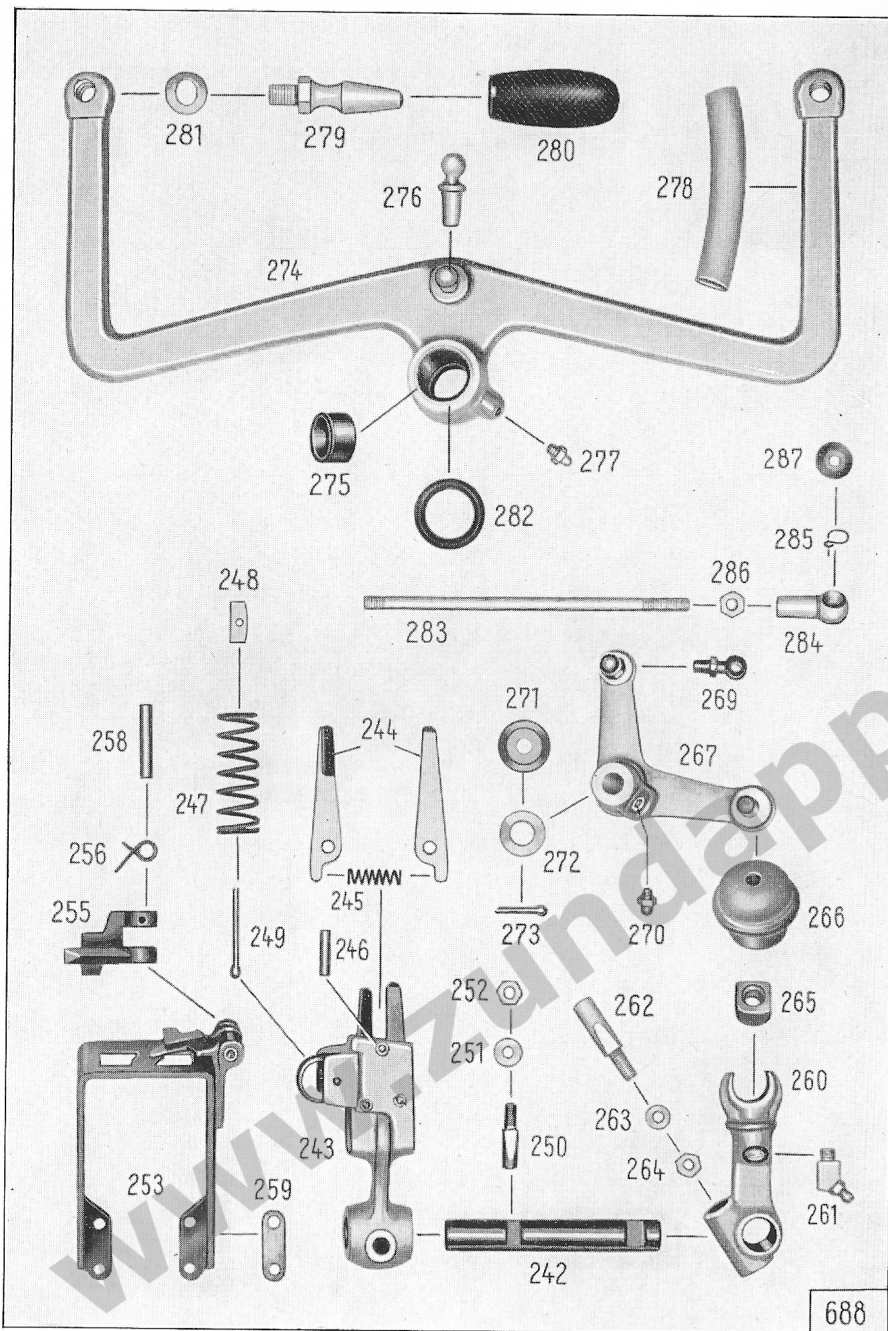

688

Illustration 10, Group G: d) Footshift Mechanism

| Key No. | Spare Part No. | Description | No. of Pieces | Remarks |
|----------------------------|----------------|--|---------------|---|
| Footshift Mechanism | | | | |
| 242 | 1941 z 308 | footshift shaft (for gear selector fork) | 1 | } up to F. 90222 and from F. 90301 to 90317 |
| 243 | 670 k 103 | gear selector fork, complete | 1 | |
| — | 1941 z 312 | footshift shaft (for gear selector fork) | 1 | } from F. 90223 to 90300 and from F. 90318 |
| — | 670 k 230 | gear selector fork, complete | 1 | |
| 244 | 841 z 35 | selector finger | 2 | |
| 245 | 321 z 317 | pressure spring | 1 | |
| 246 | — | pin A 5 h 9 × 20 DIN 7341 | 3 | |
| 247 | 321 z 316 | return spring | 1 | |
| 248 | 1281 z 359 | joint | 2 | |
| 249 | — | split pin 3 × 35 DIN 94 | 1 | |
| 250 | 121 z 545 | cotter pin (to fasten gear selector fork to footshift shaft) | 1 | } up to F. 90222 and from F. 90301 to 90317 |
| — | 121 z 1112 | cotter pin (to fasten gear selector fork to footshift shaft) | 1 | |
| 251 | — | spring washer B 6 DIN 137 k | 2 | } from F. 90223 to 90300 and from F. 90318 |
| 252 | — | hex. nut M 6 DIN 934 k | 1 | |
| 253 | 200 z 101 | gear selector support with ratchet | 1 | |
| 255 | 841 z 36 | ratchet | 1 | |
| 256 | 321 z 322 | ratchet spring | 1 | |
| 258 | — | pin A 6 h 9 × 32 DIN 7341 (to fasten ratchet to gear selector support) | 1 | |
| 259 | 1281 z 242 | joint } | 4 | } at option |
| — | 1281 z 243 | joint } to gear selector support.. | 4 | |
| — | 1281 z 244 | joint } | 4 | |
| 260 | 671 z 315 | gearshift lever | 1 | |
| 261 | — | grease nipple D 6 DIN 71412 | 1 | |
| 262 | 121 z 553 | cotter pin (to fasten gearshift lever to shaft) | 1 | |
| 263 | — | spring washer B 6 DIN 137 k | 2 | |
| 264 | — | hex. nut M 6 DIN 934 k | 1 | |
| 265 | 574 z 6 | sliding block (to gearshift lever) .. | 1 | |
| 266 | 616 z 215 | rubber sleeve (to gearshift lever) | 1 | |

Illustration 10, Group G: d) Footshift Mechanism

| Key No. | Spare Part No. | Description | No. of Pieces | Remarks |
|---------|----------------|------------------------------------|---------------|---------|
| 267 | 670 z 214 | angle lever | 1 | |
| 269 | — | ball pivot B 10 × 8 DIN 71803 | 1 | |
| 270 | — | grease nipple D 6 DIN 71412 | 1 | |
| 271 | 1236 z 310 | rubber ring | 2 | |
| 272 | — | washer 10,5 DIN 125 k | 1 | |
| 273 | — | split pin 3 × 18 DIN 94 k | 1 | |
| 274 | 680 z 26 | footshift lever | 1 | |
| 275 | 184 z 516 | bushing (in footshift lever) | 2 | |
| 276 | 131 z 523 | ball pivot | 1 | |
| 277 | — | grease nipple D 6 DIN 71412 | 1 | |
| 278 | 1596 z 294 | hose | 2 | |
| 279 | 121 z 1039 | bolt | 2 | |
| 280 | 616 z 231 | rubber sleeve | 2 | |
| 281 | — | spring washer A 10 DIN 137 k | 2 | |
| 282 | 1236 z 315 | packing washer | 2 | |
| 283 | 1651 z 312 | gearshift rod | 1 | |
| 284 | — | ball pot B 10 DIN 71805 k | 2 | |
| 285 | — | clip S 10 DIN 71805 k | 2 | |
| 286 | — | hex. nut M 6 DIN 934 k | 1 | |
| 287 | 616 z 11 | rubber ring | 2 | |

Illustration 11, Group R: a) Frame

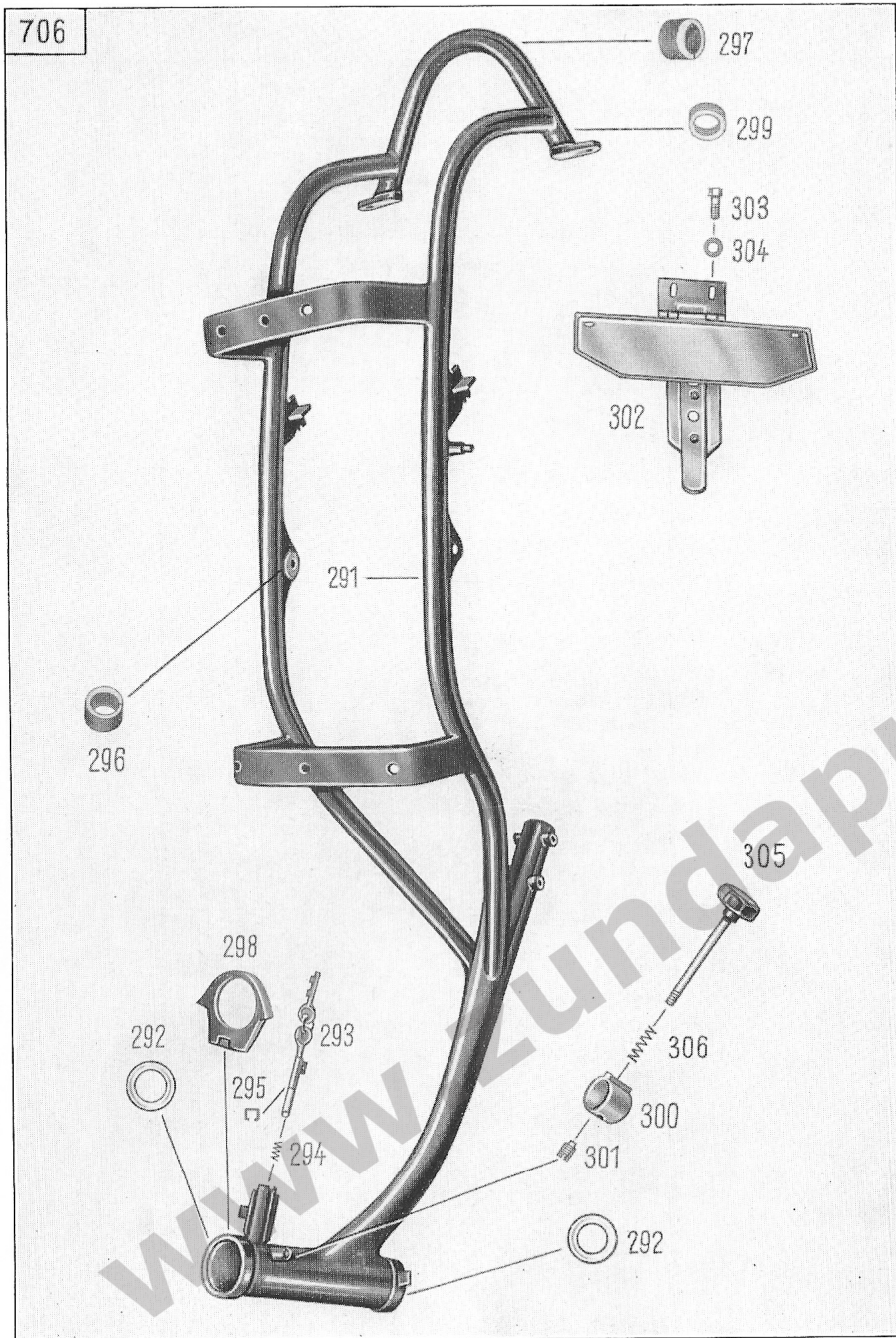

Illustration 11, Group R: a) Frame

| Key No. | Spare Part No. | Description | No. of Pieces | Remarks |
|--------------|----------------|---|---------------|------------------------|
| Frame | | | | |
| 291 | 6690 z 322 | frame | 1 | up to F. 88920 |
| — | 6690 z 323 | frame | 1 | from F. 88921 |
| 292 | 1871 z 171 | frame race | 2 | |
| 293 | 6040 z 274 | antitheft lock | 1 | |
| 294 | 321 z 537 | spring (to antitheft lock) | 1 | |
| 295 | 211 z 250-3 | clip (to fasten antitheft lock) | 1 | |
| — | — | hex. screw M 6 × 10 DIN 933 k (to fasten cable for earth terminal to frame) | 1 | |
| — | — | spring washer B 6 DIN 137 | 1 | |
| — | — | hex. nut M 6 DIN 934 k | 1 | |
| 296 | 616 z 234 | rubber sleeve (to fuel tank) | 4 | |
| 297 | 616 z 234 | rubber sleeve (to rear frame elbow) | 1 | |
| 298 | 1236 z 316 | rubber ring (distance piece be- tween steering tube and cover) | 1 | |
| 299 | 1236 z 334 | rubber ring | 2 | |
| 300 | 1234 z 15 | tension ring (to steering damper) | 1 | |
| — | — | dowel pin 3 × 8 DIN 1476 k | 1 | |
| 301 | — | bolt M 8 × 15 DIN 417 k | 1 | |
| 305 | 590 z 102 | grip with bolt | 1 | |
| — | 1291 k 106 | retaining circlip | 1 | |
| — | — | washer 8,4 DIN 433 | 1 | |
| 306 | 321 z 023 | spring | 1 | |
| 302 | 1140 z 1248 | supporting bracket with joint band | 1 | please quote colour |
| — | 1140 z 1247 | supporting bracket | 1 | |
| — | 1151 z 208 | joint band | 1 | |
| — | — | rivet, button head 4 × 22 DIN 660 Ms | 2 | |
| 303 | 1551 z 437-3 | hex. screw (to fasten supporting bracket to frame) | 1 | |
| — | 181 z 346-3 | spacer bushing | 1 | |
| 304 | — | shim 6,4 DIN 125 k | 1 | |
| — | — | hex. screw M 6 × 15 DIN 933 k (to fasten joint band to frame) | 2 | |
| — | 1241 z 34 | ring | 2 | |
| — | — | spring washer A 6 DIN 137 k | 2 | |

Illustration 12, Group R: a) Frame, Front Engine Carrier and Center Stand

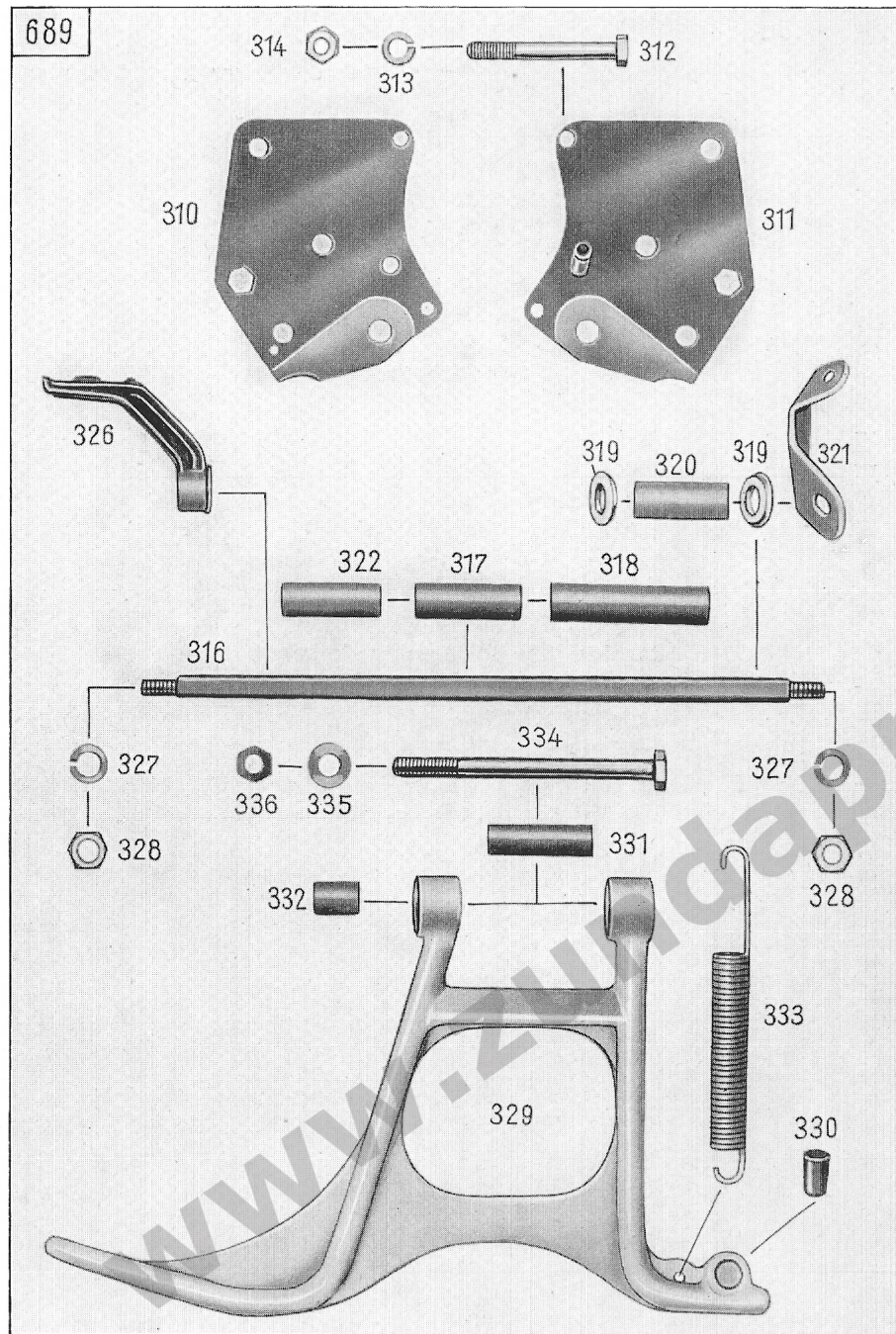

Illustration 12, Group R: a) Frame, Front Engine Carrier and Center Stand

| Key No. | Spare Part No. | Description | No. of Pieces | Remarks |
|-----------------------------|----------------|---|---------------|----------------|
| Front Engine Carrier | | | | |
| 310 | 1180 z 304 | engine suspending plate, left-hand | 1 | |
| 311 | 1180 z 305 | engine suspending plate, right-hand | 1 | |
| 312 | — | hex. screw M 10 × 80 DIN 931 k (to fasten engine suspending plates to frame) | 1 | |
| — | — | hex. screw M 10 × 90 DIN 931 k (to fasten engine suspending plates to frame) | 1 | |
| 313 | — | spring washer A 10 DIN 127 k | 2 | |
| 314 | — | hex. nut M 10 DIN 934 k | 2 | |
| 316 | 121 z 1099 | front bearing bolt | 1 | |
| 317 | 1331 z 778 | spacer tube (between engine suspension plates) | 1 | |
| 318 | 1331 z 842 | spacer tube, right-hand | 1 | |
| 319 | 1301 z 656 | spacer washer | 2 | |
| — | 1236 z 315 | packing washer | 2 | |
| 320 | 1331 z 767 | spacer tube (for footshift lever) | 1 | |
| 321 | 631 z 585 | front foot board support, right-hand | 1 | |
| 322 | 1331 z 840 | spacer tube, left-hand | 1 | |
| 326 | 631 z 561 | front foot board support, left-hand | 1 | |
| 327 | — | spring washer A 12 DIN 127 k | 2 | |
| 328 | — | hex. nut M 12 DIN 934 k (on bearing bolt) | 2 | |
| Center Stand | | | | |
| 329 | 1753 z 7 | center stand | 1 | up to F. 88920 |
| — | 1753 z 9 | center stand | 1 | from F. 88921 |
| 330 | 616 z 219 | rubber damper | 1 | |
| 331 | 1331 z 781 | spacer tube (betw. engine suspension plates) | 1 | |
| 332 | 1331 z 780 | spacer tube (to hex. screw) | 2 | |
| 333 | 321 z 545 | return spring | 1 | |
| 334 | — | hex. screw M 12 × 140 DIN 931 (to fasten center stand to front engine carrier) | 1 | |
| 335 | — | spring washer B 12 DIN 137 | 2 | |
| — | 1301 z 01 | spacer shim 12,3 × 26 × 0,5 | } as required | |
| — | 1301 z 669 | spacer shim 12,3 × 26 × 0,2 | | |
| — | 1301 z 670 | spacer shim 12,3 × 26 × 0,3 | | |
| 336 | — | hex. nut M 12 DIN 934 | 1 | |

Illustration 13, Group R: a) Frame, Rear Engine Carrier and Swinging Fork

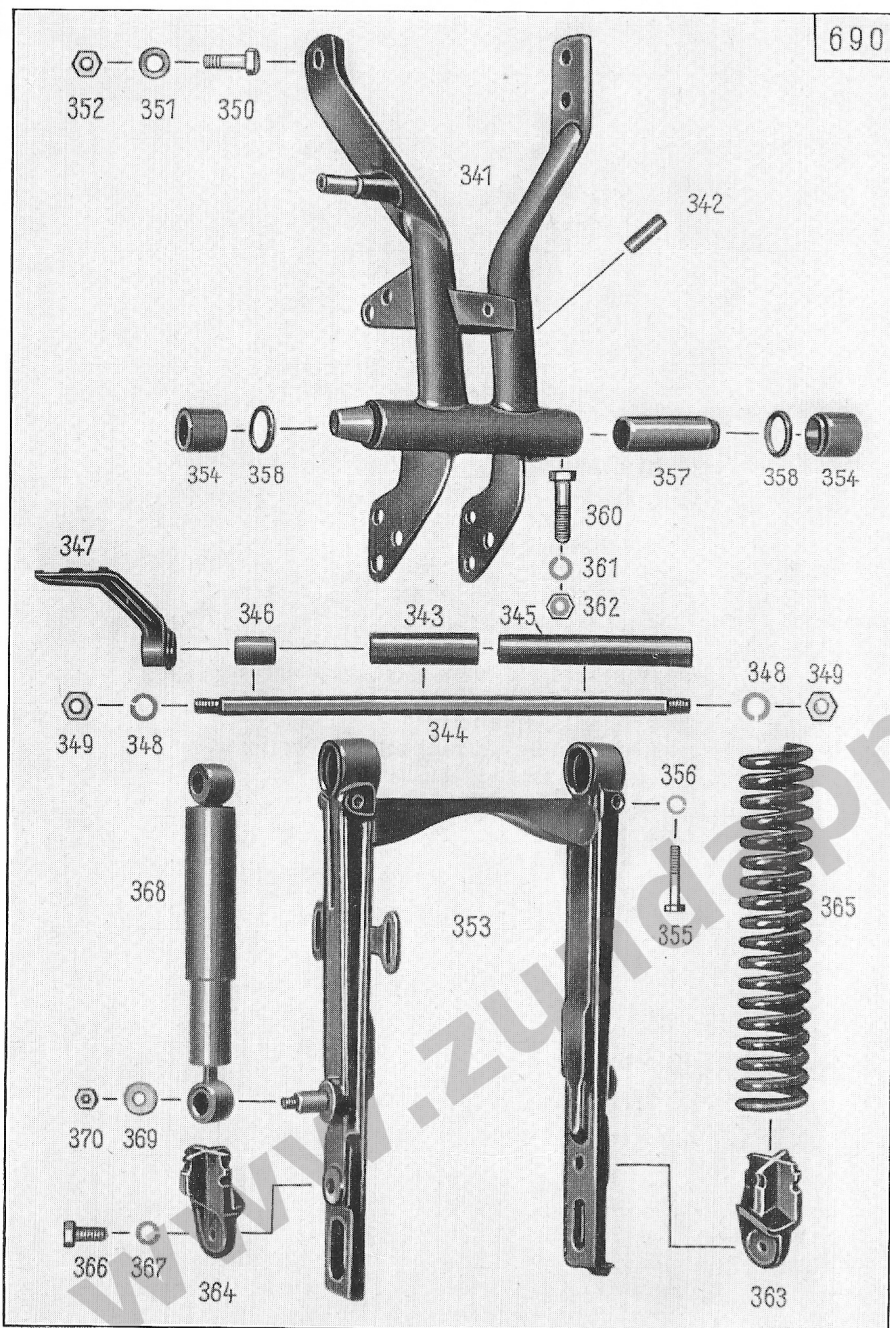

Illustration 13, Group R: a) Frame, Rear Engine Carrier and Swinging Fork

| Key No. | Spare Part No. | Description | No. of Pieces | Remarks |
|----------------------------|----------------|--|---------------|---------|
| Rear Engine Carrier | | | | |
| 341 | 630 z 481 | rear engine carrier | 1 | |
| 342 | 616 z 224 | plug | 1 | |
| 343 | 1331 z 773 | spacer tube (betw. engine suspension plates) | 1 | |
| 344 | 121 z 1100 | rear bearing bolt | 1 | |
| 345 | 1331 z 841 | spacer tube (rear left side) | 1 | |
| 346 | 1331 z 843 | spacer tube (rear right side) | 1 | |
| 347 | 631 z 605 | rear foot board carrier | 1 | |
| 348 | — | spring washer A 12 DIN 127 k | 2 | |
| 349 | — | hex. nut M 12 DIN 934 k (on bearing bolt) | 2 | |
| 350 | — | hex. screw M 10 × 35 DIN 931 a (to fasten rear engine carrier to frame) .. | 2 | |
| 351 | — | spring washer B 10 DIN 137 k | 2 | |
| 352 | — | hex. nut M 10 DIN 934 k | 2 | |
| Swinging Fork | | | | |
| 353 | 710 z 203 | rear swinging fork | 1 | |
| 354 | 184 z 517 | bushing for swinging fork | 2 | |
| 355 | — | hex. screw M 8 × 40 DIN 931 k (to fasten bushing to swinging fork) | 2 | |
| 356 | — | spring washer A 8 DIN 127 | 2 | |
| 357 | 121 z 1084 | bearing bolt, right-hand | 1 | |
| — | — | hex. screw M 6 × 6 DIN 933 k | 1 | |
| — | — | spring washer B 6 DIN 137 k | 1 | |
| 358 | 1236 z 320 | rubber ring } betw. swinging fork | } at option | |
| — | 1236 z 321 | rubber ring } and | | |
| — | 1236 z 322 | rubber ring } engine carrier | | |
| 360 | — | hex. screw M 10 × 40 DIN 931 k (to fasten bearing bolt to engine carrier) | 1 | |
| 361 | — | spring washer A 10 DIN 127 k | 1 | |

Illustration 13, Group R: a) Frame, Rear Engine Carrier and Swinging Fork

| Key No. | Spare Part No. | Description | No. of Pieces | Remarks |
|---------|----------------|---|---------------|---------|
| 362 | — | hex. nut M 10 DIN 934 k | 1 | |
| 363 | 631 z 578 | lower spring carrier, right-hand .. | 1 | |
| 364 | 631 z 577 | lower spring carrier, left-hand | 1 | |
| 365 | 321 z 569 | spring | 2 | |
| — | 616 z 246 | rubber sleeve | 2 | |
| 366 | — | hex. screw M 10 x 22 DIN 933 k (to fasten spring carrier to swinging arm) | 2 | |
| 367 | — | spring washer A 10 DIN 127 k | 1 | |
| 368 | 6350 z 101 | shock absorber | 1 | |
| — | 2376 k 2 | rubber sleeve | 4 | |
| 369 | 1301 z 168 | washer | 2 | |
| 370 | — | hex. nut M 8 DIN 934 k | 2 | |

Illustration 14, Group R: b) Foot Boards and Folding Grids

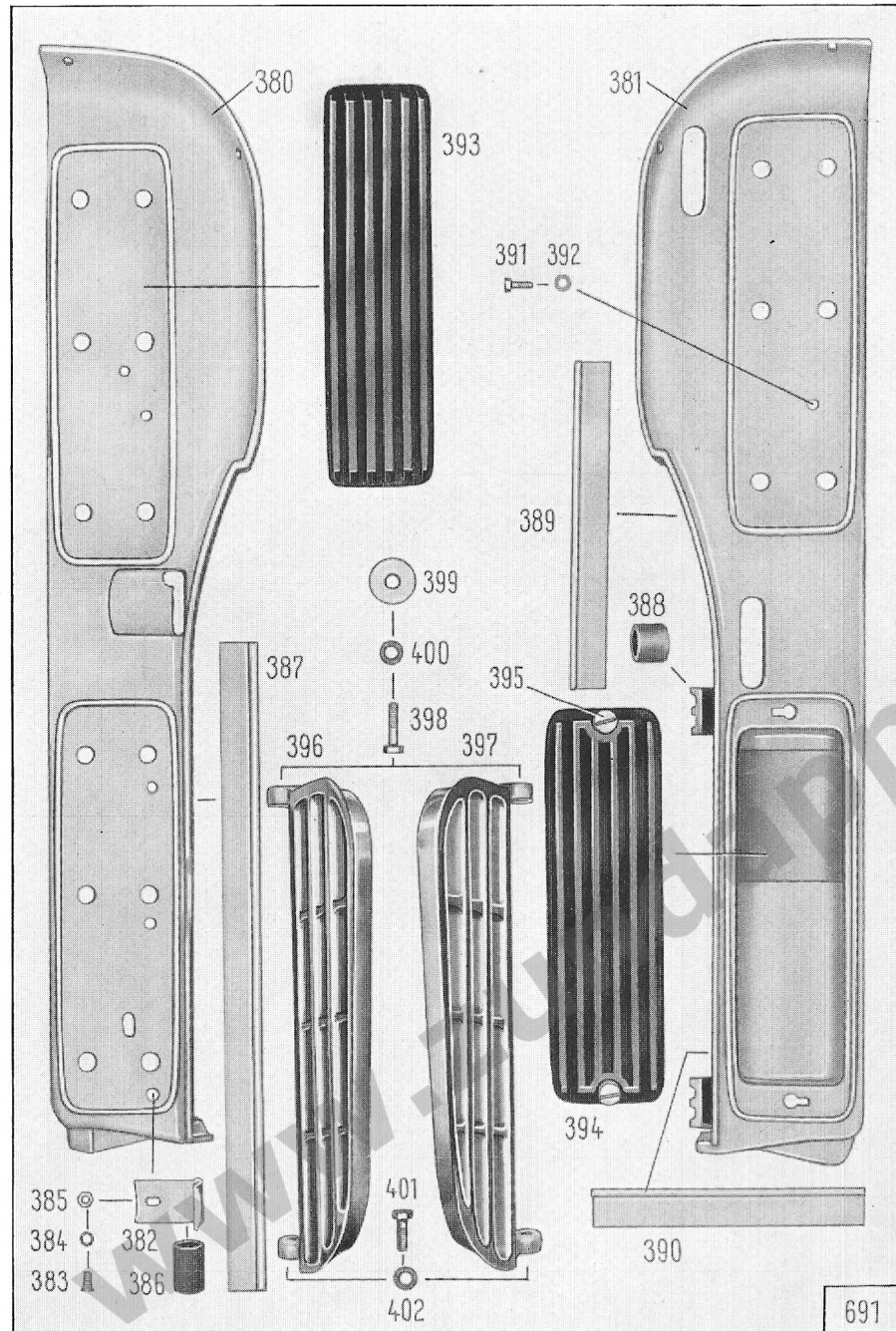

Illustration 14, Group R: b) Foot Boards and Folding Grids

| Key No. | Spare Part No. | Description | No. of Pieces | Remarks |
|----------------------|----------------|---|-------------------------|---|
| Foot Boards | | | | |
| 380 | 473 z 23 | foot board, left-hand | 1 | |
| 381 | 473 z 31 | foot board, right-hand | 1 | |
| 382 | 631 z 560 | support (left foot board) | 2 | |
| 383 | — | screw, countersunk head M 6 × 12 DIN 63 k (to fasten support to foot board) | 2 | |
| 384 | — | spring washer B 6 DIN 137 k | 2 | |
| 385 | — | hex. nut M 6 DIN 934 k | 2 | |
| 386 | 1596 z 404 | rubber hose | 2 | } foot board, left-hand |
| 387 | 1397 z 20 | beading | 1 | |
| 388 | 1236 z 338 | ring | 2 | |
| 389 | 1397 z 16 | front beading | 1 | } foot board, right-hand |
| 390 | 1397 z 17 | rear beading | 1 | |
| 391 | — | hex. screw M 6 × 15 DIN 933 k (to fasten foot board to foot board carrier) | 2 | |
| — | — | hex. screw M 6 × 18 DIN 933 k (to fasten left foot board to foot board carrier) | 1 | |
| — | — | washer 6,4 DIN 134 k | 1 | |
| 392 | — | spring washer B 6 DIN 137 k | 3 | |
| 393 | 1146 z 65 | rubber foot mat | 3 | |
| 394 | 1146 z 92 | rear right foot mat | 1 | |
| — | 1141 z 2134-7 | supporting bracket | 1 | |
| — | 1301 z 1010-3 | washer | 2 | |
| 395 | 131 z 534-3 | locking bolt | 2 | |
| — | — | dowel pin 3 × 16 DIN 1472 k | 2 | |
| Folding Grids | | | | |
| 396 | 653 z 113 | folding grid, left-hand | 1 | |
| 397 | 653 z 114 | folding grid, right-hand | 1 | |
| 398 | — | hex. screw M 8 × 30 DIN 931 k (to fasten folding grids to foot board) | 2 | |
| 399 | 1301 z 661 | spacer shim 8,4 × 30 × 0,5 | } as re- quir- ed | } betw. folding grids and foot boards |
| — | 1301 z 662 | spacer shim 8,4 × 30 × 1,0 | | |
| — | 1301 z 674 | spacer shim 8,4 × 28 × 2,0 | | |
| 400 | — | spring washer B 8 DIN 137 k | 2 | |
| 401 | — | hex. screw M 8 × 25 DIN 931 k (to fasten folding grids to frame) | 2 | |
| 402 | — | spring washer B 8 DIN 137 k | 2 | |

Illustration 15, Group R: d) Mudguards, Front Mudguard

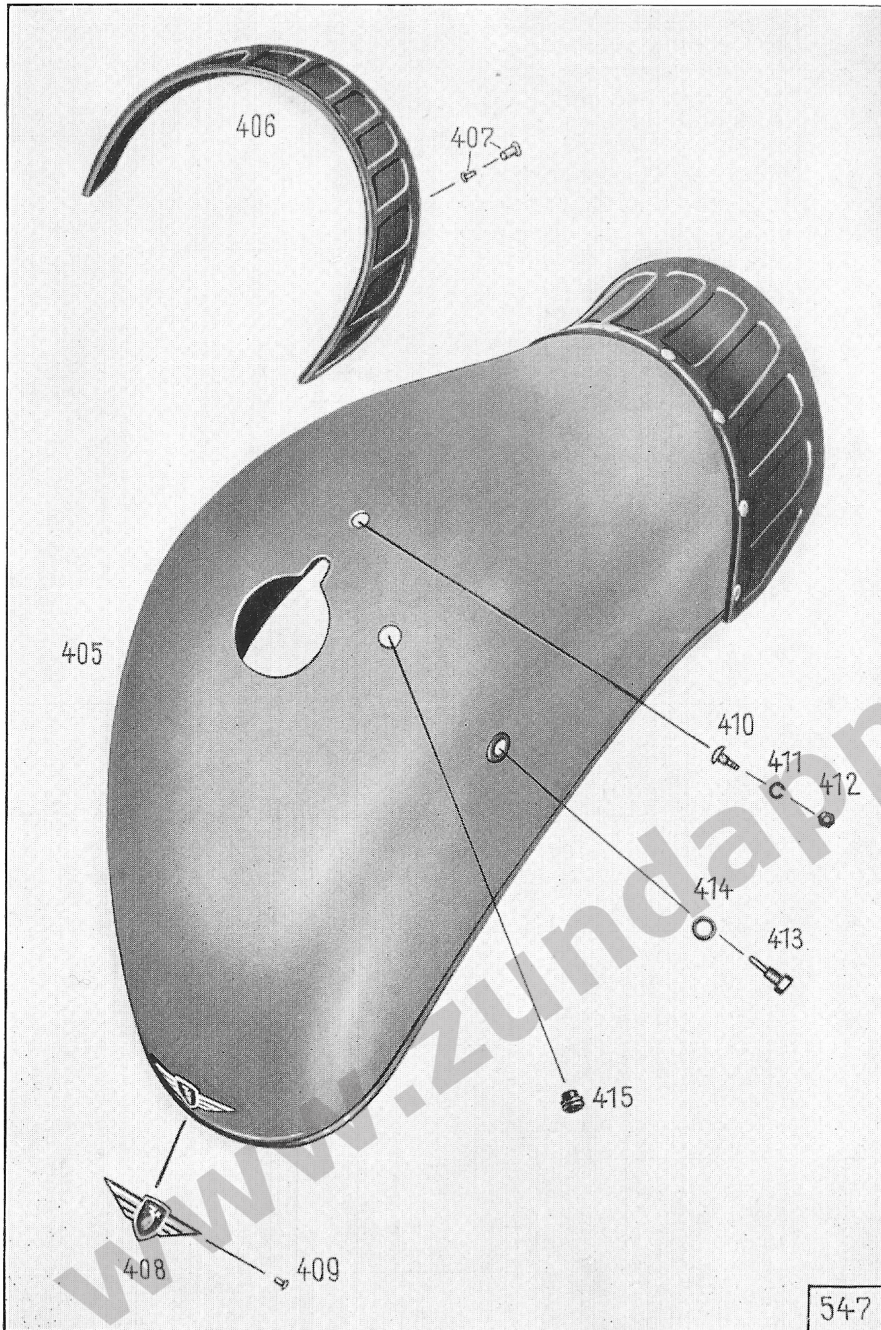

Illustration 15, Group R: d) Mudguards, Front Mudguard

| Key No. | Spare Part No. | Description | No. of Pieces | Remarks |
|---|----------------|--|---------------|---------------------|
| Front Mudguard (up to Frame 88920) | | | | |
| 405 | 6370 k 139 | front mudguard with rubber apron | 1 | please quote colour |
| 406 | 616 z 250 | rubber apron | 1 | |
| 407 | — | rivet, hollow A 4 × 11 × 12 DIN 7331 | 8 | |
| 408 | 1483 z 54 | manufacturer's plate | 1 | please quote colour |
| 409 | — | rivet, button head 2,6 × 6 DIN 660 Alu | 2 | |
| 410 | — | screw M 6 × 15 DIN 603 k (to fasten front mudguard to front fork) .. | 1 | |
| 411 | — | spring washer A 6 DIN 127 k | 1 | |
| 412 | — | hex. nut M 6 DIN 934 k | 1 | |
| 413 | 1550 z 106 | hex. screw (to fasten front mudguard to front fork and simultaneously oil filler screw for front fork) | 2 | |
| 414 | — | washer 8,4 DIN 125 k | 2 | |
| 415 | 616 z 216 | grommet (to front brake cable) .. | 1 | |
| Front Mudguard (from Frame 88921) | | | | |
| — | 6370 z 156 | front mudguard | 1 | please quote colour |
| 408 | 1483 z 54 | manufacturer's plate | 1 | please quote colour |
| — | — | rivet, button head 2,6 × 6 DIN 660 Alu | 2 | |
| — | — | screw M 6 × 15 DIN 603 k (to fasten front mudguard to swinging arm) | 1 | |
| — | — | spring washer A 6 DIN 127 k | 1 | |
| — | — | hex. nut M 6 DIN 934 k | 1 | |
| — | — | hex. screw M 8 × 10 DIN 933 crp (to fasten front mudguard to swinging arm) | 2 | |
| — | — | spring washer A 8 DIN 137 k | 2 | |
| 415 | 616 z 216 | grommet (to front brake cable) .. | 1 | |

Illustration 16, Group R: d) Mudguards, Rear Mudguard and Chain Case

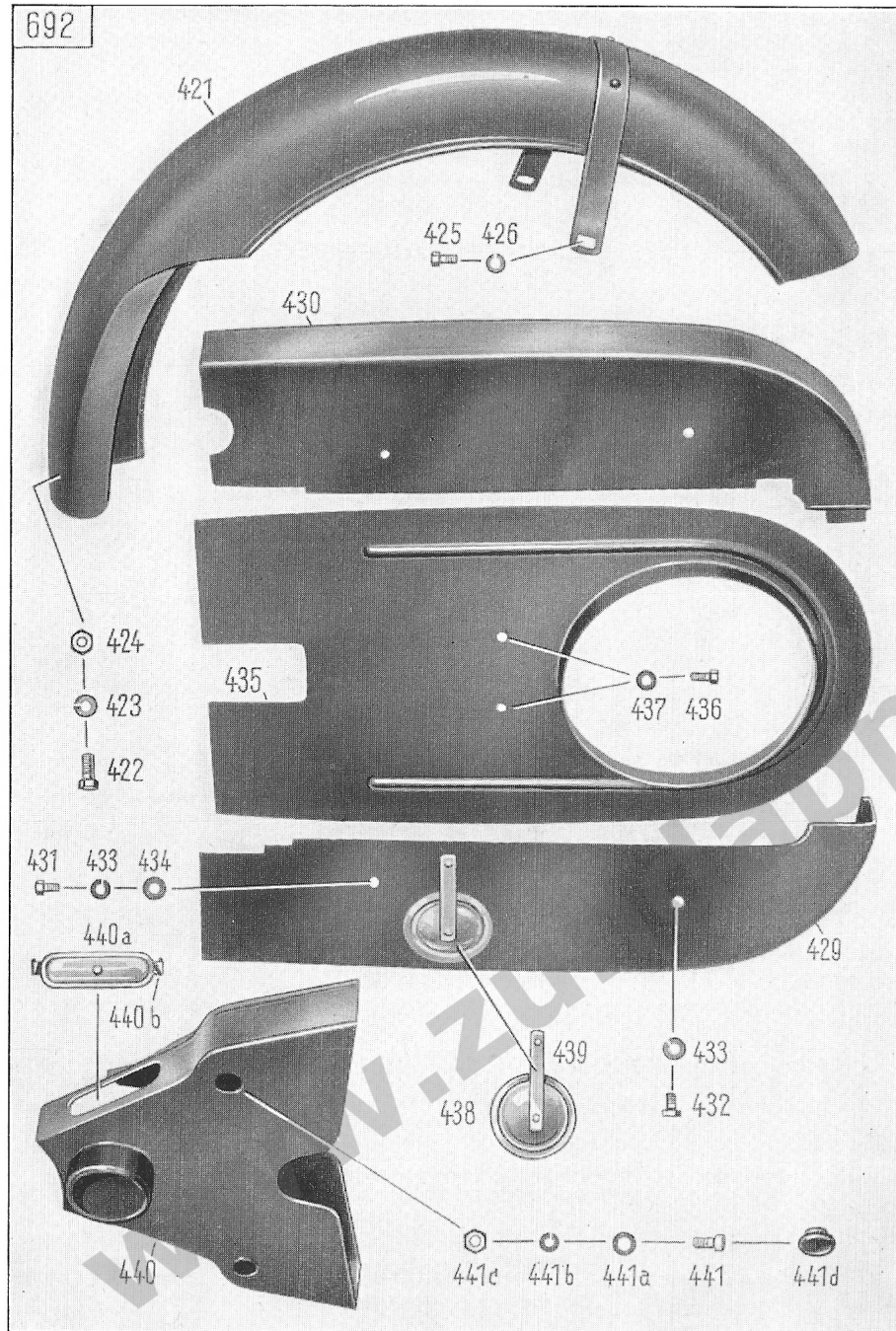

Illustration 16, Group R: d) Mudguards, Rear Mudguard and Chain Case

| Key No. | Spare Part No. | Description | No. of Pieces | Remarks |
|----------------------|----------------|---|---------------|---------|
| Rear Mudguard | | | | |
| 421 | 6370 z 152-7 | rear mudguard | 1 | |
| 422 | — | hex. screw M 8 × 15 DIN 933 k (to fasten rear mudguard to rear engine carrier) | 1 | |
| 423 | — | spring washer A 8 DIN 127 k | 1 | |
| 424 | — | hex. nut M 8 DIN 934 k | 1 | |
| 425 | — | hex. screw M 6 × 12 DIN 933 k (to fasten rear mudguard to frame) | 2 | |
| 426 | — | spring washer A 6 DIN 127 k | 2 | |
| Chain Case | | | | |
| 429 | 1500 z 258-8 | chain case, lower front part | 1 | |
| 430 | 1500 z 259-8 | chain case, upper front part | 1 | |
| 431 | — | hex. screw M 6 × 10 DIN 933 k (to fasten chain case front parts to swinging fork) | 2 | |
| 432 | — | hex. screw M 6 × 12 DIN 933 k (to fasten chain case front parts to swinging fork) | 2 | |
| 433 | — | spring washer B 6 DIN 137 k | 4 | |
| 434 | — | washer 6,4 DIN 125 k | 2 | |
| 435 | 1501 z 184-8 | chain case, rear part | 1 | |
| 436 | — | hex. screw M 6 × 12 DIN 933 k (to fasten chain case rear part to brake cover) | 2 | |
| 437 | — | spring washer B 6 DIN 137 k | 2 | |
| 438 | 230 z 216 | cap | 1 | |
| 439 | 331 z 303 | laminated spring | 1 | |
| — | — | rivet, button head 4 × 6 DIN 660 (to fasten laminated spring to cap as well as to chain case front part) | 2 | |
| — | — | washer 4,3 DIN 125 k | 1 | |
| — | — | spring washer B 5 DIN 137 k | 1 | |

Rear Mudguard and Chain Case

Illustration 16, Group R: d) Mudguards,

| Key No. | Spare Part No. | Description | No. of Pieces | Remarks |
|---------|----------------|--|---------------|---------|
| 440 | 650 z 319-7 | protecting cover | 1 | |
| 440a | 230 z 232 | cap | 1 | |
| 440b | 331 z 328-3 | laminated spring | 1 | |
| — | — | rivet, button head 4 × 6 DIN 660 (to fasten laminated spring to cap) | 1 | |
| 441 | — | cylindrical screw M 8 × 15 DIN 84 k (to fasten protecting cover to rear engine carrier) | 1 | |
| 441a | — | spring washer A 8 DIN 137 k | 1 | |
| 441b | — | spring washer A 8 DIN 127 k | 1 | |
| — | 1301 z 52 | shim 8,5 × 18 × 0,2 | } as required | |
| — | 1301 z 53 | shim 8,5 × 18 × 0,3 | | |
| — | 1301 z 54 | shim 8,5 × 18 × 0,4 | | |
| 441c | — | hex. nut M 8 DIN 934 k | 1 | |
| 441d | 616 z 228 | plug (for protecting cover) | 1 | |

Illustration 17, Group R: e) Front Shield



Illustration 17, Group R: e) Front Shield

| Key No. | Spare Part No. | Description | No. of Pieces | Remarks |
|---------------------|----------------|--|---------------|------------------------------------|
| Front Shield | | | | |
| 442 | 650 z 314 | front shield with wind guiding shield, complete | 1 | please quote colour up to F. 86882 |
| — | 650 z 356 | front shield with wind guiding shield, complete | 1 | please quote colour from F. 86883 |
| 443 | 1596 z 296 | rubber hose | 4 | |
| 444 | 741 z 30 | retaining wire | 2 | |
| 445 | 651 z 236 | wind guiding shield | 1 | |
| — | — | screw, button head AM 4 × 10 DIN 86 k (to fasten wind guiding shield to front shield) | 3 | |
| — | — | spring washer B 5 DIN 137 k | 3 | |
| — | — | washer 4,3 DIN 125 k | 2 | |
| — | — | hex. nut M 4 DIN 934 k | 3 | |
| — | — | hex. screw M 6 × 15 DIN 933 k (to fasten front shield to foot boards) | 4 | |
| — | — | hex. screw M 6 × 12 DIN 933 k (to fasten front shield to foot boards) | 2 | |
| — | — | spring washer B 6 DIN 137 k | 12 | |
| — | — | hex. nut M 6 DIN 934 k | 6 | |
| 446 | 1483 z 42 | plate (Bella) | 1 | |
| — | — | rivet, button head 1,4 × 4 DIN 660 Alu | 5 | |
| 447 | 1487 z 51 | decorative plate (flower) | 1 | |
| — | 173 z 110 | spacer tube | 1 | |
| — | — | rivet, countersunk head 2 × 10 DIN 661 Alu | 1 | |
| — | 1397 z 11 | rubber beading | 2 | |
| — | — | hex. screw M 6 × 25 DIN 933 k (to fasten dashboard cover to front shield) | 1 | |
| — | — | washer 6,4 DIN 125 | 1 | |
| — | — | hex. nut M 6 DIN 934 k | 2 | |
| 448 | 1806 z 104 | rubber grommet (to set of cables) | 1 | |
| 449 | 1806 z 02 | rubber grommet (to set of cables) | 1 | |

Illustration 18, Group R: e) Front Cover, Dash Board with Cover

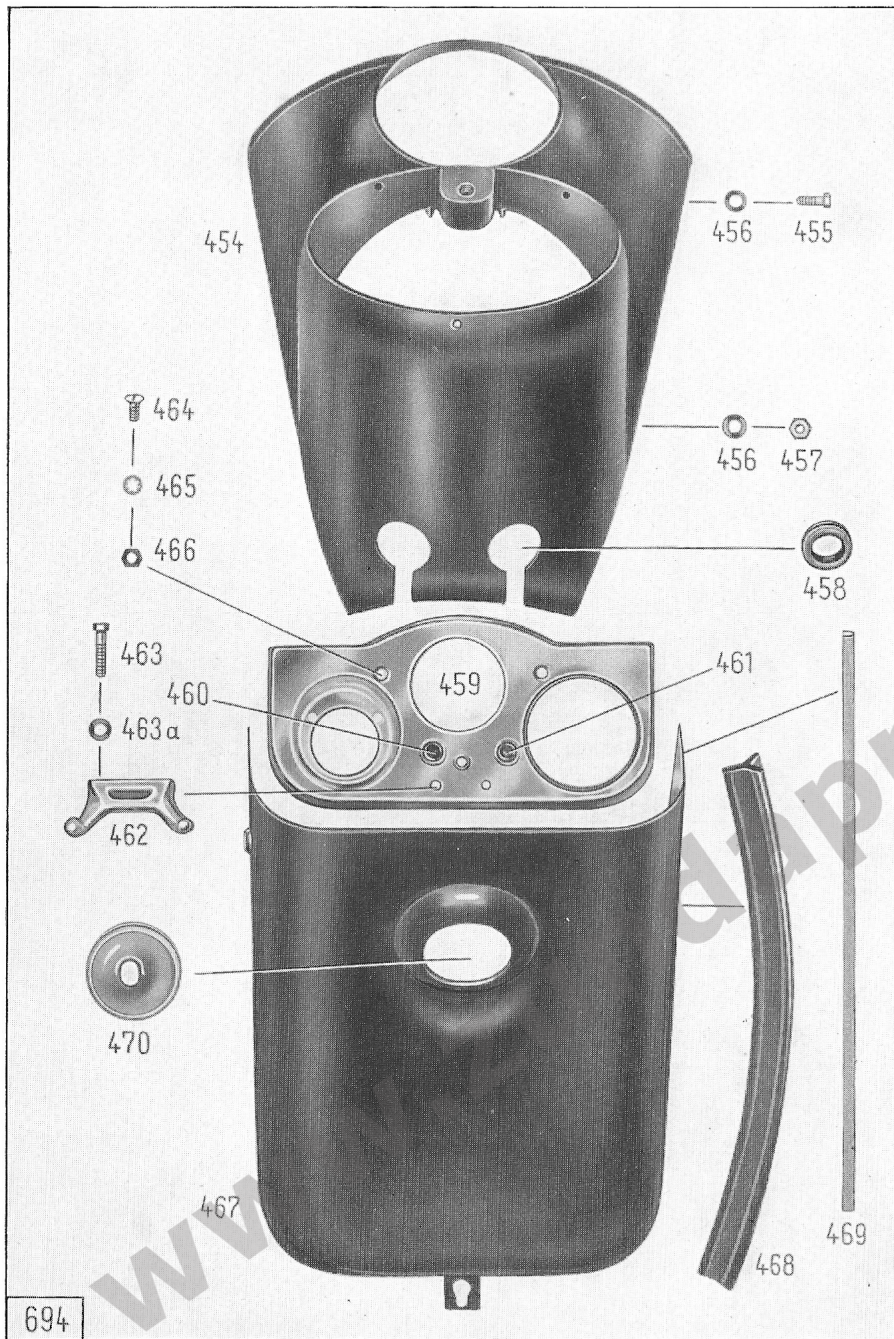
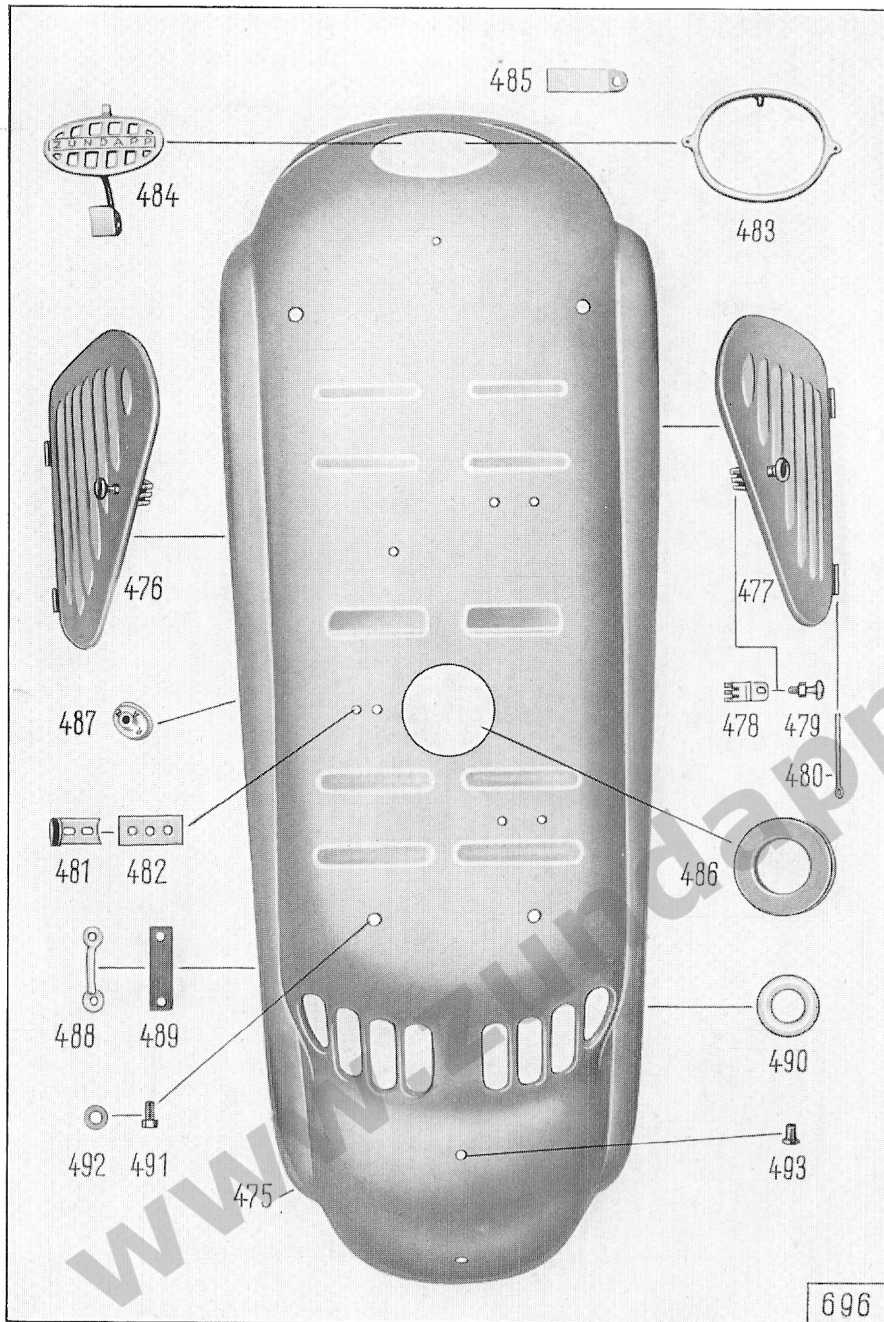

Illustration 18, Group R: e) Front Cover, Dash Board with Cover

| Key No. | Spare Part No. | Description | No. of Pieces | Remarks |
|--|----------------|---|---------------|--------------------------------------|
| Front Cover | | | | |
| 454 | 650 k 320-8 | front cover | 1 | please quote colour |
| 455 | — | hex. screw M 6 × 15 DIN 933 k (to fasten front cover to front shield) | 2 | |
| 456 | — | spring washer B 6 DIN 137 k | 6 | } please state colour |
| 457 | — | hex. nut M 6 DIN 934 k | 2 | |
| — | 1396 z 243 | double beading, left-hand | 1 | |
| — | 1396 z 244 | double beading, right-hand | 1 | |
| 458 | 1806 z 104 | rubber grommet | 2 | |
| Dash Board | | | | |
| 459 | 483 z 316 | dash board | 1 | |
| 460 | 1110 z 19 | inspection glass (for charge control lamp) | 1 | |
| 461 | 1110 z 20 | inspection glass (for idle control lamp) | 1 | |
| 462 | 1113 z 3 | loop hole (for a strap, etc.) | 1 | |
| 463 | — | cylindrical screw AM 5 × 25 DIN 84 k (to fasten loop hole to dash board) | 1 | |
| — | — | cylindrical screw AM 5 × 35 DIN 84 k (to fasten loop hole as well as holder for control lamps within dash board) | 1 | |
| 463a | — | spring washer B 5 DIN 137 k | 2 | |
| 464 | — | screw, countersunk raised head AM 6 × 12 DIN 91 crp (to fasten dashboard to front shield) | 3 | |
| 465 | — | shake-proof washer J 6,4 DIN 6797 k | 3 | |
| 466 | — | hex. nut M 6 DIN 934 k | 3 | |
| — | 1596 z 418 | profile rubber (piece of a hose) for dashboard | 2 | } please quote colour-up to F. 86882 |
| 467 | 650 z 313 | cover (for dashboard) | 1 | |
| — | 650 z 353 | cover (for dashboard) | 1 | } please quote colour-from F. 86883 |
| — | 1110 z 19 | inspection glass (for flashlight) .. | 1 | |
| 468 | 1396 z 240 | profile rubber | 2 | } please quote colour |
| 469 | 1396 z 239 | profile rubber | 1 | |
| — | 1146 z 94 | rubber plate | 2 | |
| 470 | 1236 z 317 | rubber ring (for antitheft lock) | 1 | |
| — | 616 z 229 | grommet (to steering damper) .. | 1 | |
| (For electric parts see under headlight) | | | | |

Illustration 19, Group R: e) Rear Body



696

Illustration 19, Group R: e) Rear Body

| Key No. | Spare Part No. | Description | No. of Pieces | Remarks |
|------------------|----------------|--|---------------|-----------------------|
| Rear Body | | | | |
| — | 650 z 305 | rear body (up to F. 81620) | 1 | } please quote colour |
| 475 | 650 z 337 | rear body (from F. 81621) | 1 | |
| 476 | 650 k 309 | left grid with lock | 1 | |
| 477 | 650 z 213 | right grid with lock | 1 | |
| 478 | 331 z 326 | lock spring | 2 | |
| 479 | 593 z 103 | lock button | 2 | |
| — | — | spring washer B 6 DIN 137 k | 2 | |
| — | — | hex. nut M 6 DIN 934 k | 2 | |
| 480 | — | split pin 4 × 60 DIN 94 k (to fasten grids to body) | 4 | |
| 481 | 2051 z 553 | locking angle (to dual seat) | 1 | |
| 482 | 1141 z 2130 | supporting sheet | 1 | |
| — | — | hex. screw M 6 × 12 DIN 933 k (to fasten locking angle to body) | 2 | |
| — | — | spring washer B 6 DIN 137 k | 2 | |
| — | — | hex. nut M 6 DIN 934 k | 2 | |
| 483 | 1483 z 53 | moulding | 1 | |
| — | — | rivet, button head 3 × 6 DIN 660 Alu (to fasten moulding to body) | 2 | |
| 484 | 653 z 116 | locking grid | 1 | |
| — | — | pin 4 h 11 × 25 × 23 DIN 1434 k | 1 | |
| — | — | split pin 1 × 8 DIN 94 k | 1 | |
| 485 | 331 z 327 | laminated spring | 1 | |
| — | — | screw, button head AM 4 × 10 DIN 86 k (to fasten laminated spring to body) | 1 | |
| — | — | spring washer A 4 DIN 127 k | 1 | |
| — | — | hex. nut M 4 DIN 934 k | 1 | |
| — | 616 z 251 | rubber grommet (for sealing fuel tank) | 1 | up to F. 81620 |
| 486 | 616 z 254 | rubber grommet (for sealing fuel tank) | 1 | from F. 81621 |
| 487 | 616 z 244 | rubber grommet (to extension for fuel tap) | 1 | |
| 488 | 1111 z 224 | loop hole (for a strap, etc.) | 2 | please quote colour |
| 489 | 1141 z 2140 | supporting sheet | 2 | |

Illustration 19, Group R: e) Rear Body

| Key No. | Spare Part No. | Description | No. of Pieces | Remarks |
|---------|----------------|--|---------------|---------|
| — | — | screw, countersunk raised head AM 6 × 12 DIN 91 k (to fasten loop hole to rear body) | 4 | |
| — | — | spring washer A 6 DIN 137 k | 4 | |
| — | — | hex. nut M 6 DIN 934 k | 4 | |
| 490 | 1243 z 10 | protection ring | 4 | |
| 491 | — | hex. screw M 8 × 18 DIN 933 crp (to fasten rear body to frame) | 2 | |
| — | — | hex. screw M 8 × 18 DIN 933 k (to fasten rear body to frame) | 2 | |
| 492 | — | spring washer B 8 DIN 137 k | 4 | |
| 493 | 616 z 242 | plug (for locking lower hole des- tined for fixing spare wheel bracket) | 1 | |

Illustration 20, Group R: e) Dual Seat

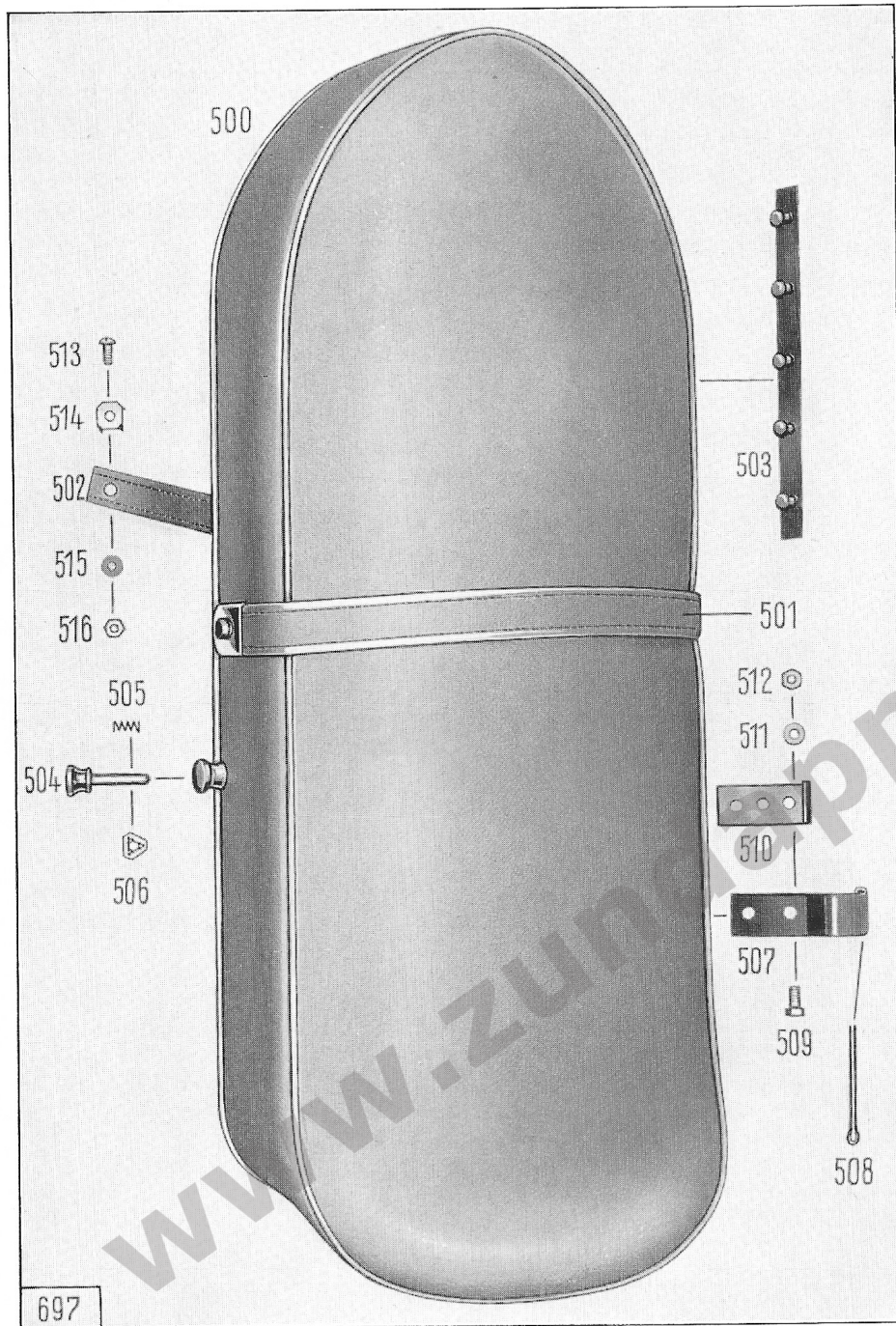

Illustration 20, Group R: e) Dual Seat

| Key No. | Spare Part No. | Description | No. of Pieces | Remarks |
|------------------|----------------|--|---------------|---------------------|
| Dual Seat | | | | |
| 500 | 6330 k 43 | dual seat complete | 1 | please quote colour |
| — | 6346 z 11 | foam rubber cushion | 1 | |
| — | 6340 z 78 | dual seat cover | 1 | please quote colour |
| — | — | screw, countersunk raised head S 3,5 × 9,5 DIN 7973 k (to fasten dual seat cover) | 14 | |
| — | — | screw, countersunk raised head S 3,5 × 13 DIN 7973 k (to fasten dual seat cover) | 2 | |
| — | 1284 z 15 | washer | 16 | |
| 501 | 2360 k 1 | holding strap | 1 | please quote colour |
| — | 1143 z 105 | holding plate | 2 | |
| — | 1141 z 2143 | clamping plate | 2 | |
| — | — | hex. screw M 6 × 20 DIN 933 crp (to fasten holding strap to frame of dual seat) | 2 | |
| — | — | spring washer A 6 DIN 137 k | 2 | |
| 502 | 2360 k 2 | retaining strap | 1 | please quote colour |
| 503 | 946 z 6 | rubber band for buttons or | 2 | |
| — | 1126 z 1 | supporting bolt | 4 | |
| 504 | 590 z 109 | lock button | 1 | |
| 505 | 321 z 549 | spring | 1 | |
| 506 | 1251 z 258 | triangle circlip D 6 | 1 | |
| 507 | 1151 z 206 | joining band | 2 | |
| 508 | — | split pin 4 × 60 DIN 94 k | 2 | |
| 509 | — | hex. screw M 6 × 12 DIN 933 k (to fasten dual seat to rear body) | 4 | |
| 510 | 1141 z 2130 | supporting sheet | 2 | |
| 511 | — | spring washer B 6 DIN 137 k | 4 | |
| 512 | — | hex. nut M 6 DIN 934 k | 4 | |
| 513 | — | screw, button head M 5 × 12 DIN 86 k (to fasten re- taining strap to rear body) | 1 | |
| 514 | 1141 z 2143 | clamping plate | 1 | |
| 515 | — | washer 5,3 DIN 125 k | 1 | |
| 516 | — | hex. nut M 5 DIN 934 k | 1 | |

Illustration 21, Group R: f) Fuel Tank and Fuel Pipes



Illustration 21, Group R: f) Fuel Tank and Fuel Pipes

| Key No. | Spare Part No. | Description | No. of Pieces | Remarks |
|------------------|----------------|---------------------------------------|---------------|------------------|
| Fuel Tank | | | | |
| — | 6230 z 127-7 | fuel tank | 1 | } up to F. 81620 |
| — | 1850 z 101 | filler cap | 1 | |
| — | 2456 k 5-0 | gasket (for filler cap) | 1 | |
| 520 | 6230 z 135-7 | fuel tank | 1 | } from F 81621 |
| 521 | 1850 z 103-0 | filler cap | 1 | |
| 522 | 1236 z 342 | rubber ring (for filler cap) | 1 | |
| — | 1146 z 78 | felt piece (to fuel tank) | 1 | |
| 523 | 1390 z 116 | tie (to fasten fuel tank to frame) .. | 1 | |
| 524 | 1146 z 58 | support (below tie) | 4 | |
| 525 | 6010 z 162 | fuel tap | 1 | |
| 526 | 1001 z 55 | nut | 1 | |
| 527 | 120 z 209 | extension (to fuel tap) | 1 | |
| 528 | 1590 z 58 | fuel hose | 1 | |

Illustration 22, Group R: h) Exhaust Set

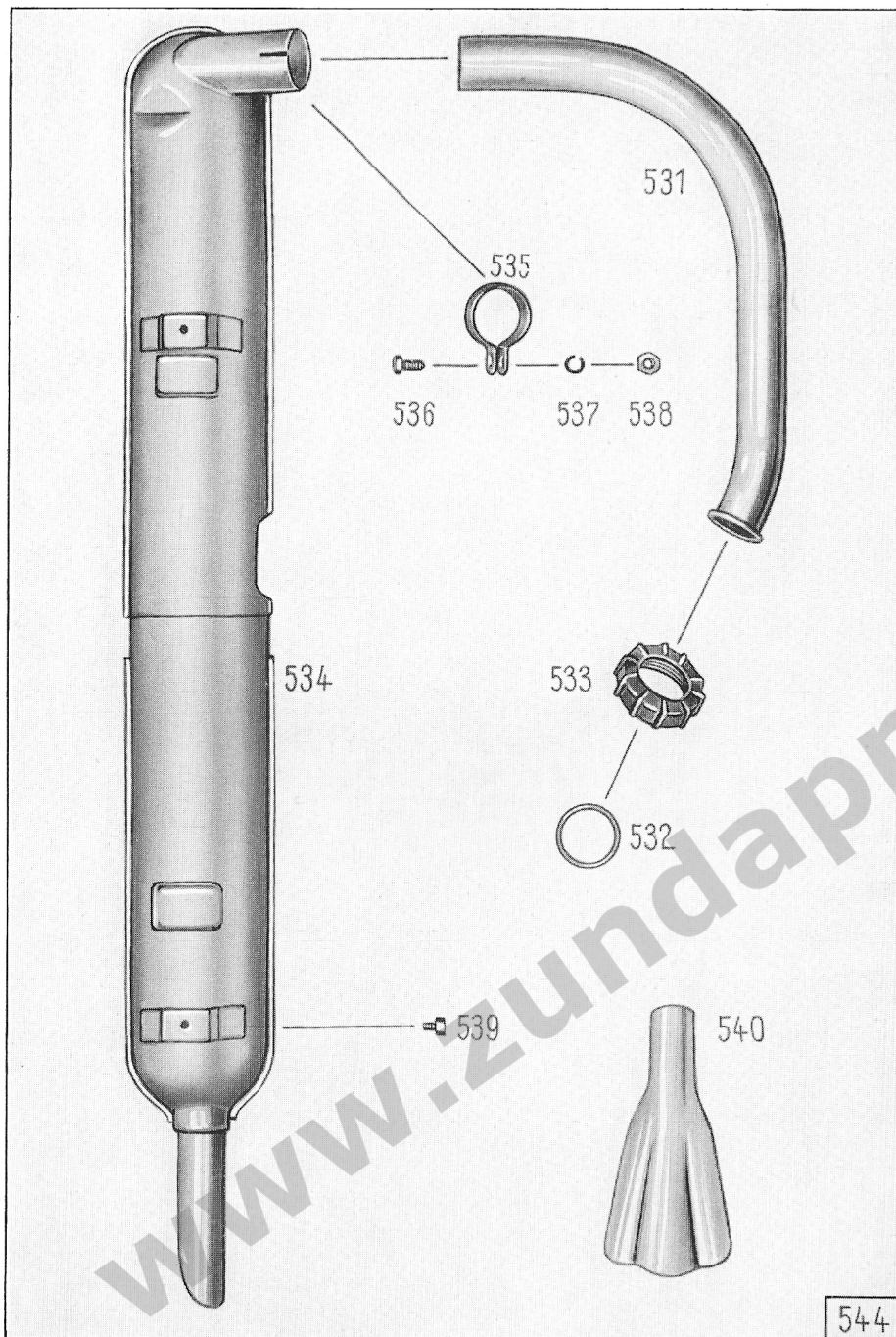

Illustration 22, Group R: h) Exhaust Set

| Key No. | Spare Part No. | Description | No. of Pieces | Remarks |
|---------------------------|----------------|--|---------------|---------|
| Exhaust Set | | | | |
| 531 | 1351 z 203 | exhaust pipe | 1 | |
| 532 | — | packing washer C 42 × 49 DIN 7603 | 2 | |
| 533 | 1011 z 90 | exhaust nut | 1 | |
| 534 | 6030 z 326 | silencer | 1 | |
| — | 2270 k 3 | silencer — end piece | 1 | |
| 535 | 1441 z 286 | clamp (to fasten silencer to exhaust pipe) | 1 | |
| 536 | — | hex. screw M 8 × 18 DIN 933 k | 1 | |
| 537 | — | spring washer A 8 DIN 127 k | 1 | |
| 538 | — | hex. nut M 8 DIN 934 k | 1 | |
| 539 | — | hex. screw M 6 × 15 DIN 933 k (to fasten silencer to left foot board) | 2 | |
| — | — | spring washer B 6 DIN 137 k | 2 | |
| Exhaust Tail Piece | | | | |
| 540 | 651 z 237 | exhaust tail piece | 2 | |
| — | — | hex. screw M 6 × 15 DIN 933 k (to fasten exhaust tail piece to silencer) .. | 2 | |
| — | — | spring washer B 6 DIN 137 k | 2 | |
| — | — | hex. nut M 6 DIN 934 k | 2 | |

Illustration 23, Group R: i) Front Fork

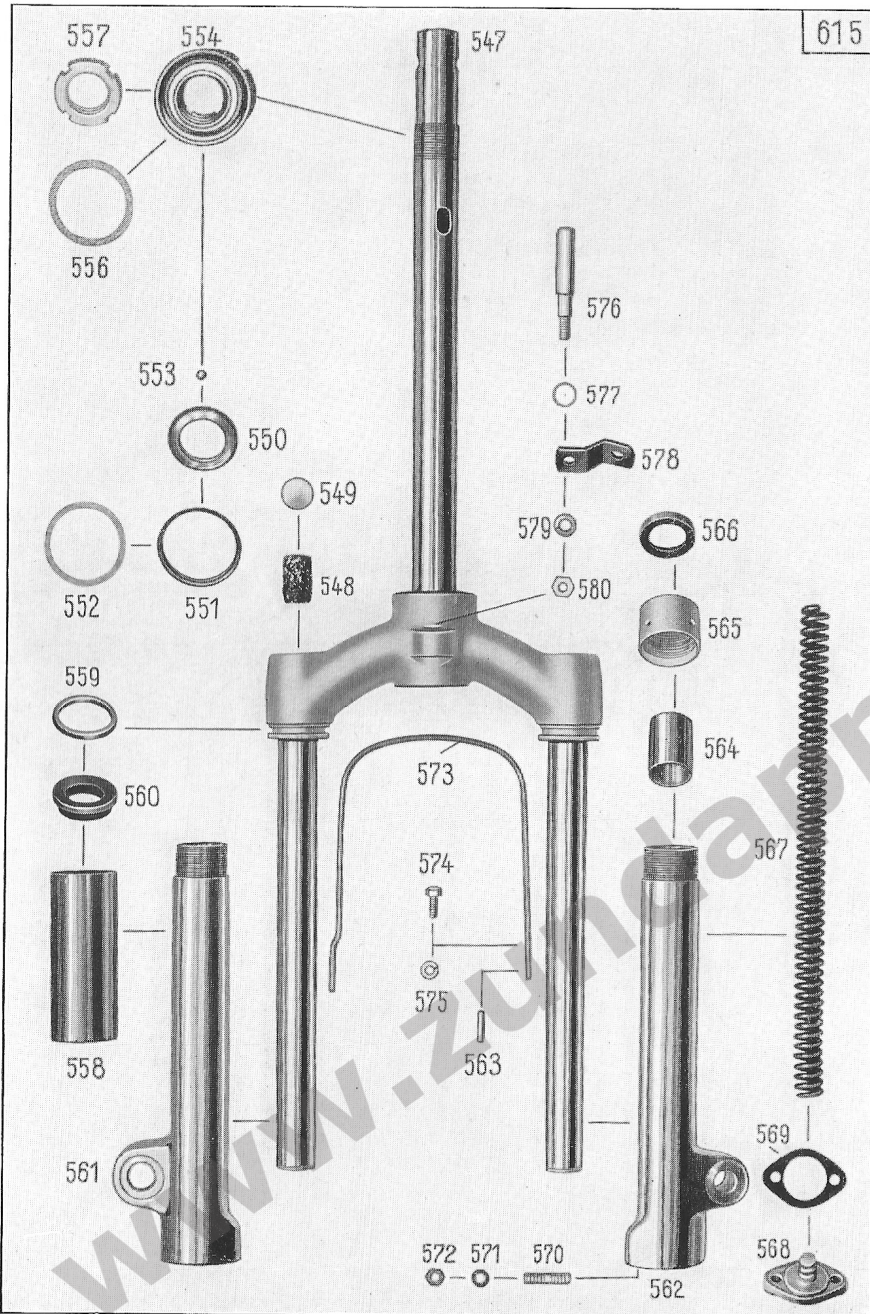

Illustration 23, Group R: i) Front Fork

| Key No. | Spare Part No. | Description | No. of Pieces | Remarks |
|---------|----------------|---|---------------|--------------------------|
| | | Front Fork (up to F. 88920) | | |
| — | 6810 z 208 | front fork complete | 1 | |
| 547 | 6800 z 101 | front fork with sliding tubes | 1 | |
| — | — | locking washer 20 DIN 470 | 1 | |
| — | — | locking washer 25 DIN 470 | 1 | |
| 548 | 2211 z 159 | wire gauze (in sliding tubes) | 2 | |
| 549 | — | locking washer 22 DIN 470 k (to lock the sliding tubes) | 2 | |
| 550 | 1871 z 170 | fork race (lower race) | 1 | |
| 551 | 1231 z 210 | covering ring | 1 | |
| 552 | 1236 z 333 | packing washer | 1 | |
| 553 | — | ball 6,35 DIN 5401 | 38 | |
| 554 | 1870 z 52 | fork race (upper race) | 1 | |
| 556 | 1236 z 336 | packing washer | 1 | |
| 557 | — | splined nut M 30 × 1 DIN 70852 k .. | 1 | |
| 558 | 1331 z 740 | protection tube | 2 | |
| 559 | 1236 z 307 | retaining ring (to protection tube) | 2 | |
| 560 | 1236 z 308 | rubber ring (in protection tube) .. | 2 | |
| 561 | 1203 z 14 | fork leg, left-hand | 1 | |
| 562 | 1203 z 15 | fork leg, right-hand | 1 | |
| 563 | — | dowel pin 5 × 12 DIN 1473 k (within right fork leg for fixing yoke) | 1 | |
| 564 | 180 z 102 | sliding bushing (in fork leg) | 2 | |
| 565 | 991 z 202 | nut | 2 | |
| 566 | 6860 z 90 | radial gasket (for above nut) | 2 | |
| 567 | 321 z 568 | spring | 2 | |
| 568 | 633 z 104 | spring carrier | 2 | |
| 569 | 468 z 310 | flange gasket (to spring carrier) .. | 2 | |
| 570 | — | stud AM 7 × 18 DIN 835 k (for fixing spring carrier to fork leg) | 4 | |
| 571 | 1301 z 433 | spring washer | 4 | |
| 572 | — | hex. nut M 7 DIN 934 k | 4 | |
| 573 | 211 z 207 | yoke (between fork legs) | 1 | |
| 574 | — | hex. screw M 6 × 15 DIN 933 k (for fixing yoke to fork legs) | 2 | |
| 575 | — | spring washer A 6 DIN 127 k | 2 | |
| 576 | 121 z 1034 | stop bolt | 1 | |
| 577 | 1301 z 85 | shim | 1 | |
| 578 | 211 z 208 | clip | 1 | |
| 579 | — | spring washer A 8 DIN 127 k | 1 | |
| 580 | — | hex. nut M 8 DIN 934 k | 1 | |
| | | Front Swinging Arm Suspension (from F. 88921) | | |
| — | 6810 k 225 | front swinging arm suspension complete | 1 | } please quote colour |
| 581 | 710 z 220 | swinging arm | 1 | |
| 581a | 184 z 525 | bushing (in bearing tube) | 2 | |

Illustration 23a, Group R: i) Front Swinging Arm Suspension

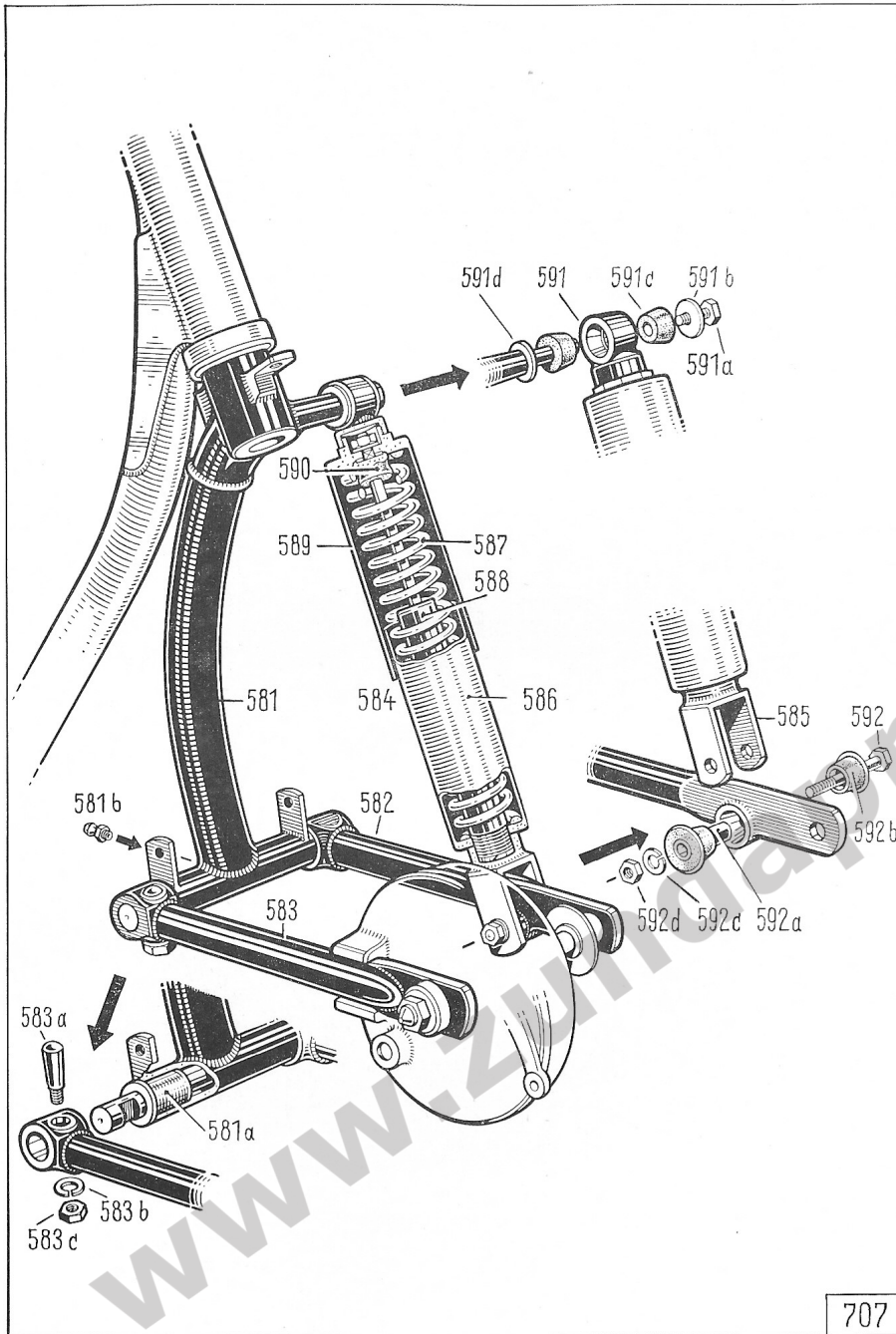

Illustration 23a, Group R: i) Front Swinging Arm Suspension

| Key No. | Spare Part No. | Description | No. of Pieces | Remarks |
|---------|----------------|---|---------------|---------------------|
| — | 1871 z 170 | fork race (on swinging arm, at bottom) | 1 | |
| — | 1301 z 07 | washer | 1 | |
| 581b | — | grease nipple D 6 DIN 71412 | 1 | |
| — | — | packing washer | 1 | |
| 582 | 710 k 241 | A 6 × 10 DIN 7603 Alu | 1 | please quote colour |
| 583 | 710 z 217 | front left swinging arm with shaft | 1 | please quote colour |
| 583a | 121 z 1085 | front right swinging arm | 1 | |
| — | — | fixing bolt (to fix swinging arm to shaft) | 1 | |
| 583b | — | spring washer A 12 DIN 127 k | 1 | |
| 583c | — | hex. nut | 1 | |
| — | — | M 12 × 1,5 DIN 936 k | 1 | |
| — | 1870 z 52 | fork race (on swinging arm, at top) | 1 | |
| — | 1236 z 336 | packing washer | 1 | |
| — | — | splined nut M 30 × 1 DIN 70852 k | 1 | |
| 584 | 6350 z 118 | spring unit complete, with hydraulic shock absorber | 1 | |
| 585 | 550 z 103 | tube head, lower | 1 | |
| — | — | spring washer A 16 DIN 127 k | 1 | |
| 585 | 170 z 216 | protection tube, inner | 1 | |
| — | 1127 z 5 | spacer bolt | 6 | |
| 587 | 321 z 582 | pressure spring | 1 | |
| 588 | 6350 z 119 | hydraulic shock absorber (brand Stabilus) | 1 | |
| — | 6350 z 120 | hydraulic shock absorber (brand Boge) | 1 | at option |
| 589 | 173 z 114 | protection tube, outer | 1 | |
| 590 | 616 z 243 | rubber damper | 1 | |
| — | 1301 z 667 | washer | 1 | |
| — | — | washer 8,4 DIN 125 k | 1 | |
| — | — | hex. nut M 8 DIN 934 k | 1 | |
| 591 | 553 z 106 | tube head, upper | 1 | |
| — | — | dowel pin, button head 3 × 8 DIN 1476 | 1 | |
| 591a | — | hex. screw M 8 × 12 DIN 933 k (for fixing spring unit to swinging fork, upper side) | 1 | |
| 591b | 1301 z 35 | washer | 1 | |
| 591c | 176 z 41 | rubber bushing | 2 | |
| 591d | — | washer 17 DIN 433 k | 1 | |
| 592 | — | hex. screw M 8 × 50 DIN 931 k (for fixing spring unit to swinging fork, lower side) | 1 | |
| 592a | 1331 z 851 | spacer tube | 1 | |
| 592b | 176 z 40 | rubber bushing | 2 | |
| — | — | washer 8,4 DIN 125 k | 1 | |
| 592c | — | spring washer A 8 DIN 127 k | 1 | |
| 592d | — | hex. nut M 8 DIN 934 k | 1 | |

Illustration 24, Group R: k) Handlebar and Handlebars with Cables

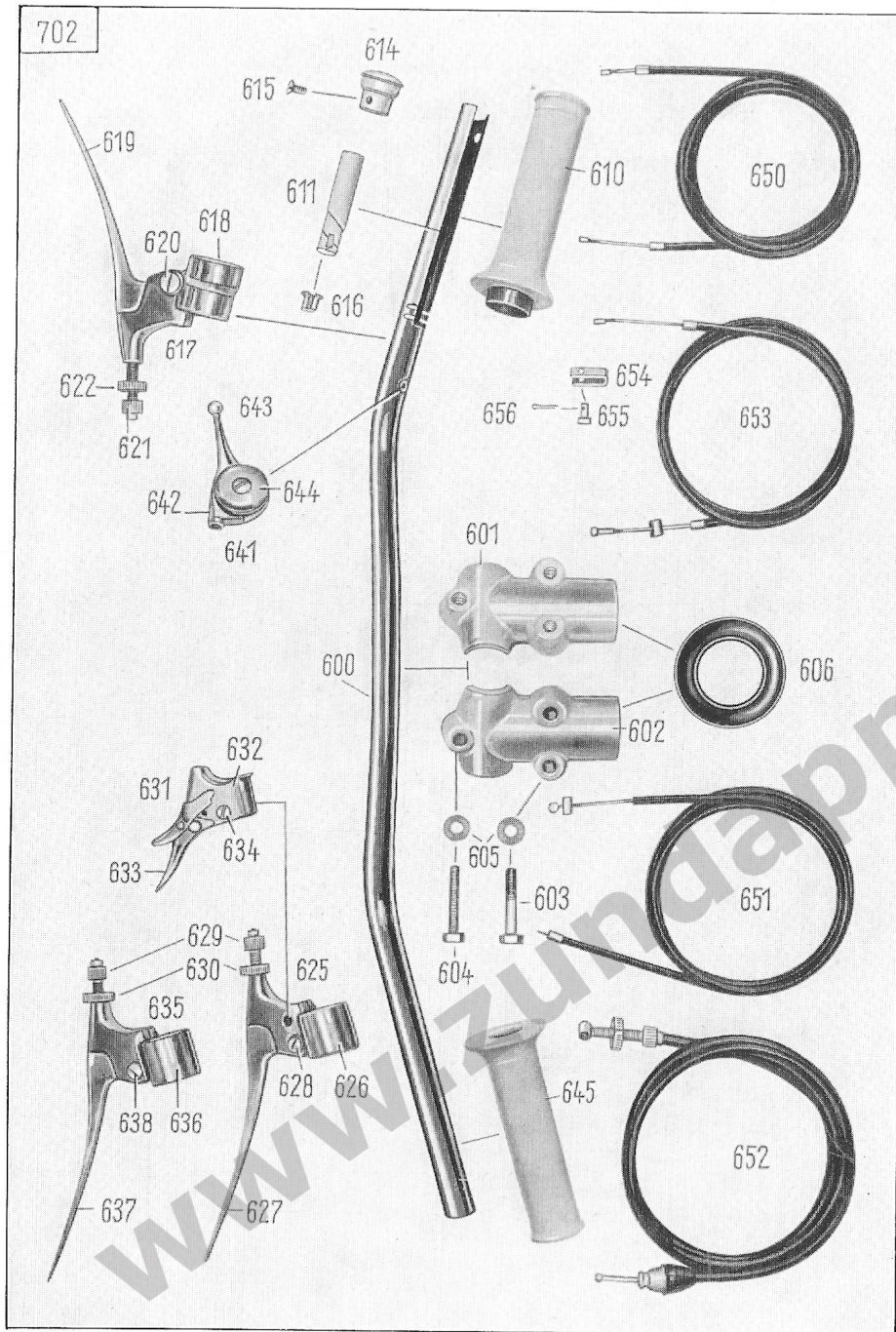

Illustration 24, Group R: k) Handlebar and Hand levers with Cables

| Key No. | Spare Part No. | Description | No. of Pieces | Remarks |
|--------------------|----------------|---|---------------|---|
| Handlebar | | | | |
| — | 1371 z 154 | handlebar | 1 | from F. 80001 to 87160 and from F. 87481 to 87830 |
| 600 | 1371 z 153 | handlebar | 1 | from F. 87161 to 87480 and from F. 87831 |
| 601 | 823 z 1 | front handlebar clamp | 1 | |
| 602 | 823 z 2 | rear handlebar clamp | 1 | |
| 603 | — | hex. screw M 8 × 40 DIN 931 crp | 2 | |
| 604 | — | hex. screw M 8 × 40 DIN 933 crp | 1 | |
| 605 | — | spring washer A 8 DIN 137 k | 3 | |
| 606 | 786 z 12 | protection cover | 1 | |
| Hand Levers | | | | |
| 610 | 170 k 203 | throttle twist grip | 1 | colour of rubber = grey |
| 611 | 2253 k 2-0 | sliding block | 1 | |
| — | 2250 k 3-0 | grip tube with rubber | 1 | } colour of rubber = grey |
| — | 2256 k 5-0 | rubber sleeve | 1 | |
| 614 | 2251 k 5-0 | lock cap | 1 | |
| 615 | — | screw, counter sunk raised head AM 5 × 10 DIN 91 k | 1 | |
| 616 | 2253 k 3-0 | cable support | 1 | |
| 617 | 670 z 211 | brake lever with cable adjustment | 1 | |
| 618 | 2263 k 5-0 | joining piece | 1 | |
| — | 2261 k 2-0 | brake spring | 1 | |
| — | 2261 k 3-3 | adjusting screw | 1 | |
| — | 2261 k 4-3 | screw, fillister head (to joining piece) | 1 | |
| 619 | 2263 k 6-0 | brake lever | 1 | |
| 620 | 2261 k 5-5 | lever screw | 1 | |
| — | — | hex. nut M 6 DIN 934 crp | 1 | |
| 621 | 2261 k 6-5 | adjusting screw | 1 | |
| 622 | 2263 k 7-0 | knurled edge nut | 1 | |

Illustration 24, Group R: k) Handlebar and Handlevers with Cables

| Key No. | Spare Part No. | Description | No. of Pieces | Remarks |
|---------|----------------|---|---------------|---|
| 625 | 670 z 228 | clutch lever with cable adjustment | 1 | |
| 626 | 2263 k 30-4 | joining piece | 1 | |
| — | 2261 k 4-3 | screw, fillister head (for joining piece) | 1 | |
| 627 | 2263 k 31-0 | clutch lever | 1 | |
| 628 | 2261 k 7-3 | lever screw | 1 | |
| — | — | shake-proof washer J 5,3 DIN 6797 | 1 | |
| — | — | hex. nut. M 5 DIN 934 crp | 1 | |
| 629 | 2261 k 1-3 | adjusting screw | 1 | |
| 630 | 2263 k 7-0 | knurled edge nut | 1 | from F. 80001 to 87160 and from F. 87481 to 87830 |
| 631 | 670 z 229 | starter lever | 1 | |
| 632 | 2260 z 2-0 | joining piece | 1 | |
| — | 2261 k 28-4 | screw, fillister head (for joining piece) | 1 | |
| — | — | shake-proof washer J 6,4 DIN 6797 | 1 | |
| — | — | tension pin 3 × 16 DIN 1481 | 1 | |
| 633 | 2260 k 1-0 | lever with ratchet | 1 | |
| — | 2261 k 26-0 | ratchet spring | 1 | |
| 634 | 2261 k 29-4 | lever screw | 1 | |
| — | — | shake-proof washer J 5,3 DIN 6797 | 1 | |
| — | — | hex. nut M 5 DIN 934 crp | 1 | |
| 635 | 670 z 207 | clutch lever with cable adjustment | 1 | |
| 636 | 2263 k 1-0 | joining piece | 1 | |
| — | 2261 k 4-3 | screw, fillister head (for joining piece) | 1 | |
| 637 | 2263 k 2-0 | clutch lever | 1 | |
| 638 | 2261 k 7-3 | lever screw | 1 | |
| — | — | hex. nut M 5 DIN 934 crp | 1 | |
| 629 | 2261 k 1-3 | adjusting screw | 1 | from F. 87161 to 87480 and from F. 87831 |
| 630 | 2263 k 7-0 | knurled edge nut | 1 | |
| 641 | 670 z 231 | starter lever | 1 | |
| 642 | 2263 k 35-4 | housing | 1 | |
| 643 | 2263 k 34-4 | lever | 1 | |
| — | 2261 k 31-0 | thrust washer | 1 | |
| — | 2261 k 30-0 | spring washer | 1 | |
| 644 | 2263 k 33-4 | covering washer | 1 | |
| — | — | screw, countersunk raised head M 6 × 22 DIN 88 crp | 1 | |
| 645 | 616 z 232 | grip | 1 | colour of rubber = grey |

Illustration 24, Group R: k) Handlebar and Handlevers with Cables

| Key No. | Spare Part No. | Description | No. of Pieces | Remarks |
|---------|----------------|---------------------------------|---------------|--|
| | | Cables | | |
| 650 | 6290 k 439 | cable for throttle twist grip | 1 | |
| — | — | nipple C DIN 71988 | 1 | |
| — | — | sleeve C 2,5 DIN 71987 | 1 | |
| 651 | 6290 k 438 | cable for starter lever | 1 | |
| — | — | nipple C DIN 71988 | 1 | from F. 80001 to 87160 and from F. 87481 to 87830 |
| — | — | nipple D DIN 71988 | 1 | |
| — | — | sleeve C 2,5 DIN 71987 | 1 | |
| — | 6290 z 443 | cable for starter lever | 1 | |
| — | — | nipple C DIN 71988 | 1 | from F. 87161 to 87480 and from F. 87831 |
| — | — | nipple D DIN 71988 | 1 | |
| — | — | sleeve C 2,5 DIN 71987 | 2 | |
| 652 | 6290 z 423 | cable for clutch | 1 | |
| — | 144 z 25 | nipple seat | 1 | |
| — | 1064 z 101 | nipple | 1 | |
| — | 1064 z 102 | nipple | 1 | |
| — | 173 z 109 | sleeve | 1 | |
| — | 1806 z 08 | rubber grommet | 1 | |
| — | 616 z 236 | rubber cover | 1 | |
| — | 2261 k 1-3 | adjusting screw | 1 | |
| — | 2263 k 7-0 | knurled edge nut | 1 | |
| 653 | 6290 k 437 | cable for front brake | 1 | |
| — | 144 z 04 | cable end | 1 | |
| — | — | nipple seat A DIN 71988 | 1 | up to F. 88920 |
| — | — | nipple B 2,3 DIN 71988 | 1 | |
| — | — | sleeve C 3 DIN 71987 | 2 | |
| — | 6290 z 445 | cable for front brake | 1 | |
| — | 144 z 04 | cable end | 1 | |
| — | — | nipple seat A DIN 71988 | 1 | from F. 88921 |
| — | — | nipple B 2,3 DIN 71988 | 1 | |
| — | — | sleeve C 3 DIN 71987 | 2 | |
| 654 | 551 z 108 | fork connecting piece | 1 | |
| 655 | 131 z 516 | bolt (to fork connecting piece) | 1 | |
| 656 | — | split pin 1,5 × 15 DIN 94 k | 1 | |

Illustration 25, Group B: a) Brakes, Handbrake

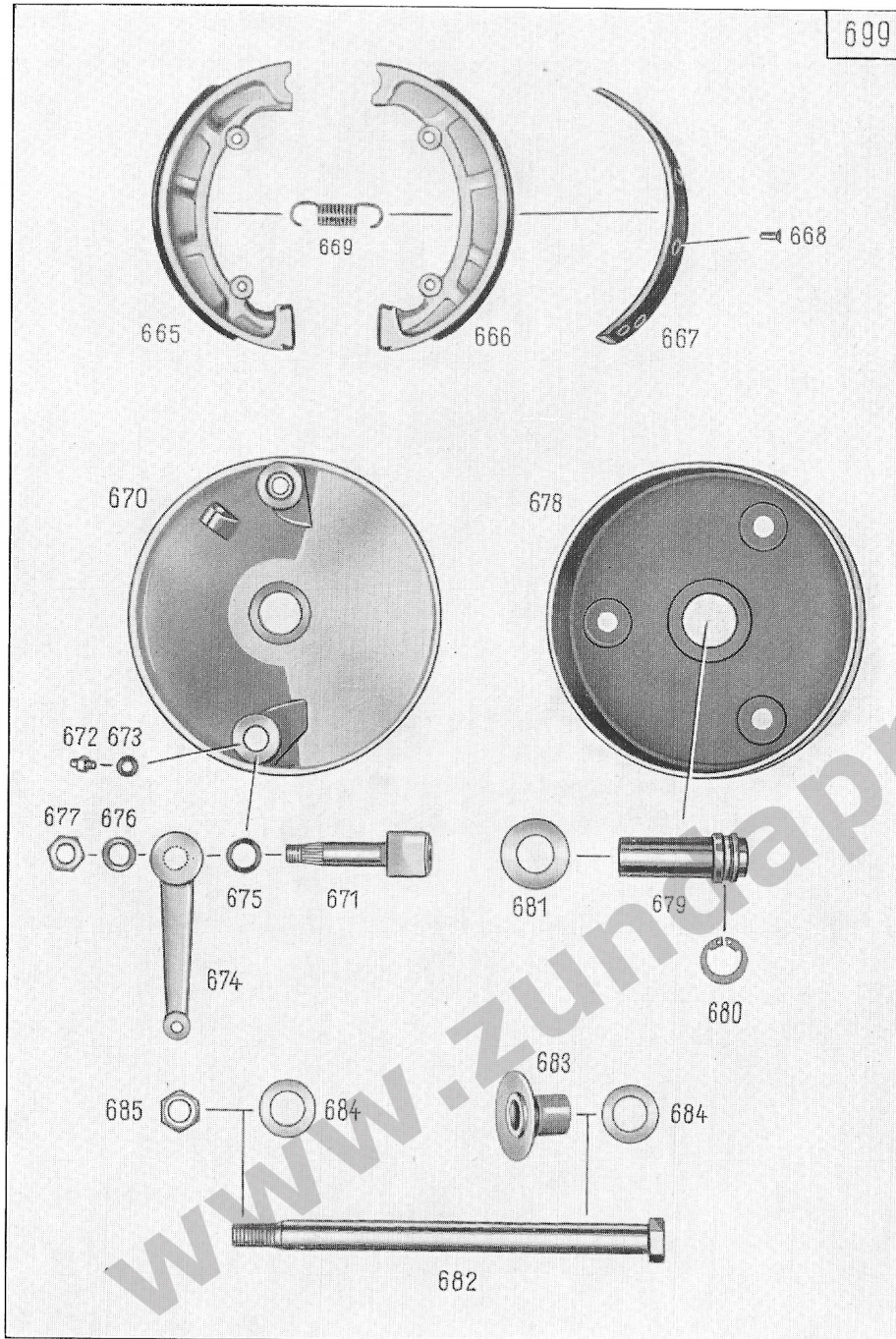

Illustration 25, Group B: a) Brakes, Handbrake

| Key No. | Spare Part No. | Description | No. of Pieces | Remarks |
|------------------|----------------|---|---------------|----------------|
| Handbrake | | | | |
| 665 | 20 z 26 | brake shoe with lining, left-hand | 1 | |
| 666 | 20 z 27 | brake shoe with lining, right-hand | 1 | |
| 667 | 49 z 12 | brake lining | 2 | |
| 668 | 1044 z 10 | cylindrical rivet | 12 | |
| 669 | 321 z 310 | return spring (betw. brake shoes) | 2 | |
| 670 | 230 z 213 | brake cover | 1 | up to F. 88920 |
| — | 230 z 233 | brake cover | 1 | from F. 88921 |
| 671 | 1100 z 8 | brake cam with supporting sheet | 1 | |
| 672 | 1080 z 1 | grease nipple | 1 | |
| 673 | — | packing washer A 6 × 10 DIN 7603 | 1 | |
| 674 | 671 z 324 | brake lever | 1 | |
| 675 | 1236 z 06 | rubber sleeve (betw. brake lever and brake cover) | 1 | |
| 676 | — | spring washer A 10 DIN 127 k | 1 | |
| 677 | — | hex. nut M 10 DIN 934 k | 1 | |
| 678 | 1791 z 203 | brake drum | 1 | |
| 679 | 121 z 1114 | bearing bushing (to brake drum) | 1 | |
| 680 | 1251 k 260 | V-circlip | 1 | |
| 681 | 1301 z 640 | washer (betw. brake cover and brake drum) | 1 | |
| 682 | 131 z 508 | front wheel axle | 1 | up to F. 88920 |
| 683 | 1330 z 167 | spacer tube 26,8 mm length | 1 | at option |
| — | 1330 z 168 | spacer tube 26,5 mm length | 1 | |
| — | 1330 z 169 | spacer tube 26,2 mm length | 1 | |
| 684 | 1301 z 1006 | washer | 1 | |
| — | 121 z 1109 | bearing bushing (to brake drum) | 1 | |
| — | 1251 k 260 | V-circlip | 1 | |
| — | 1301 z 672 | washer (betw. brake cover and brake drum) | 1 | |
| — | — | circlip 18 × 1,2 DIN 471 k | 1 | |
| — | 131 z 537 | front wheel axle | 1 | from F. 88921 |
| — | 1330 z 193 | spacer tube 23,7 mm length | 1 | |
| — | 1330 z 194 | spacer tube 24,0 mm length | 1 | |
| — | 1330 z 195 | spacer tube 24,3 mm length | 1 | at option |
| — | — | washer 17 DIN 125 k | 1 | |
| — | 1781 z 155 | pressure plate | 1 | |
| — | — | spring washer B 12 DIN 137 k | 1 | |
| 685 | — | hex. nut M 12 × 1,5 DIN 934 k | 1 | |

Illustration 26, Group B: a) Brakes, Footbrake

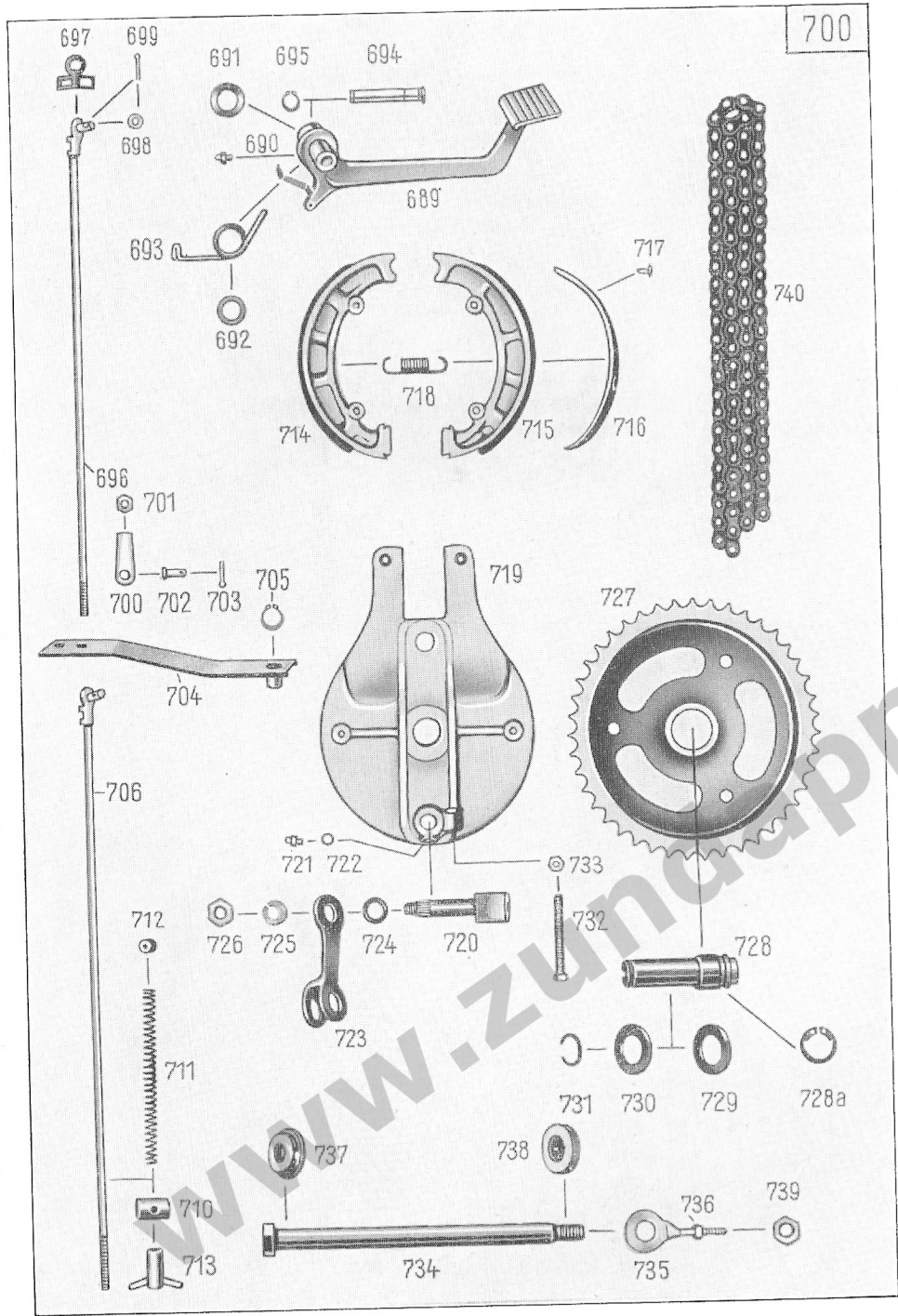

Illustration 26, Group B: a) Brakes, Footbrake

| Key No. | Spare Part No. | Description | No. of Pieces | Remarks |
|------------------|----------------|--|---------------|---------|
| Footbrake | | | | |
| 689 | 700 k 112 | footbrake lever | 1 | |
| 690 | 1080 z 1 | grease nipple | 1 | |
| — | — | packing washer A 6 × 10 DIN 7603 | 1 | |
| 691 | 1236 z 324 | packing washer | 1 | |
| 692 | 1236 z 325 | packing washer | 1 | |
| 693 | 321 z 556 | return spring | 1 | |
| 694 | 131 z 522 | bearing bolt to foot brake lever .. | 1 | |
| 695 | — | circlip 10 × 1 DIN 471 | 1 | |
| 696 | 1650 k 115 | brake rod with stop clamp | 1 | |
| 697 | 1111 z 01 | stop clamp | 1 | |
| 698 | — | washer 6,4 DIN 125 k | 1 | |
| 699 | — | split pin 2 × 12 DIN 94 (to fasten brake rod to foot brake lever) .. | 1 | |
| 700 | 551 z 18 | fork piece | 1 | |
| 701 | — | hex. nut M 6 DIN 934 k | 1 | |
| 702 | 131 z 105 | bolt (to fasten brake rod to spacer lever) | 1 | |
| 703 | — | split pin 1,5 × 12 DIN 94 | 1 | |
| 704 | 700 z 110 | footbrake spacer lever | 1 | |
| 705 | — | circlip 12 × 1 DIN 471 (to fasten foot brake spacer lever to frame) .. | 1 | |
| 706 | 1650 k 114 | rear brake rod, with stop clamp | 1 | |
| 697 | 1111 z 01 | stop clamp | 1 | |
| 698 | — | washer 6,4 DIN 125 k | 1 | |
| 699 | — | split pin 2 × 12 DIN 94 k | 1 | |
| 710 | 121 z 1046 | brake lever bolt (to rear wheel brake lever) | 1 | |
| 711 | 321 z 88 | spring | 1 | |
| 712 | 1241 z 34 | ring | 1 | |
| 713 | 1023 z 16 | toggle nut (to fasten brake rod to rear wheel brake lever) | 1 | |
| 714 | 20 z 26 | brake shoe with lining, left-hand | 1 | |
| 715 | 20 z 27 | brake shoe with lining, right-hand | 1 | |
| 716 | 49 z 12 | brake lining | 2 | |

Illustration 26, Group B: a) Brakes, Footbrake

| Key No. | Spare Part No. | Description | No. of Pieces | Remarks |
|---------|----------------|---|--------------------|--|
| 717 | 1044 z 10 | cylindrical rivet | 12 | |
| 718 | 321 z 310 | return spring (betw. brake shoes) | 2 | |
| 719 | 230 z 226 | brake cover | 1 | |
| 720 | 1100 z 8 | brake cam with supporting sheet | 1 | |
| 721 | 1080 z 1 | grease nipple | 1 | |
| 722 | — | packing washer A 6 × 10 DIN 7603 | 1 | |
| 723 | 671 z 011 | brake lever | 1 | |
| 724 | 1236 z 06 | rubber sleeve (betw. brake lever and brake cover) | 1 | |
| 725 | — | spring washer A 10 DIN 127 k | 1 | |
| 726 | — | hex. nut M 10 DIN 934 k | 1 | |
| 727 | 1791 z 211 | brake drum (48 teeth) | 1 | |
| 728 | 121 z 1115 | bearing bushing (to brake drum) .. | 1 | |
| 728a | 1251 k 261 | V-circlip | 1 | |
| 729 | 1301 z 640 | washer (betw. brake cover and brake drum) | 1 | |
| 730 | 1301 z 671 | shim 20,3 × 35 × 1,8 | } as re- quired | } betw. swinging arm and clamping ring |
| — | 1301 z 672 | shim 20,3 × 35 × 2,0 | | |
| — | 1301 z 673 | shim 20,3 × 35 × 2,2 | | |
| 731 | 1251 z 29 | clamping ring (on bearing bushing) | 1 | |
| 732 | — | hex. screw M 6 × 55 DIN 933 k (in brake cover for chain tightening) | 1 | |
| 733 | — | hex. nut M 6 DIN 934 k | 1 | |
| 734 | 131 z 510 | rear wheel axle | 1 | |
| 735 | 1111 z 209 | chain tightener | 1 | |
| 736 | — | hex. nut M 6 DIN 934 k | 2 | |
| 737 | 1243 z 7 | spacer ring | 1 | |
| 738 | 1231 z 309 | clamping ring | 1 | |
| 739 | — | hex. nut M 12 × 1,5 DIN 934 k (to rear wheel axle) | 1 | |
| 740 | — | roller chain 1 × 12,7 × 7,75 DIN 8180, 98 links incl. lock | 1 | |
| — | — | cranked double link 1 D 12,7 × 7,75 DIN 8180 | 1 | |
| — | — | lock 1 E 12,7 × 7,75 DIN 8180 | 2 | |

Illustration 27, Group B: b) Wheels

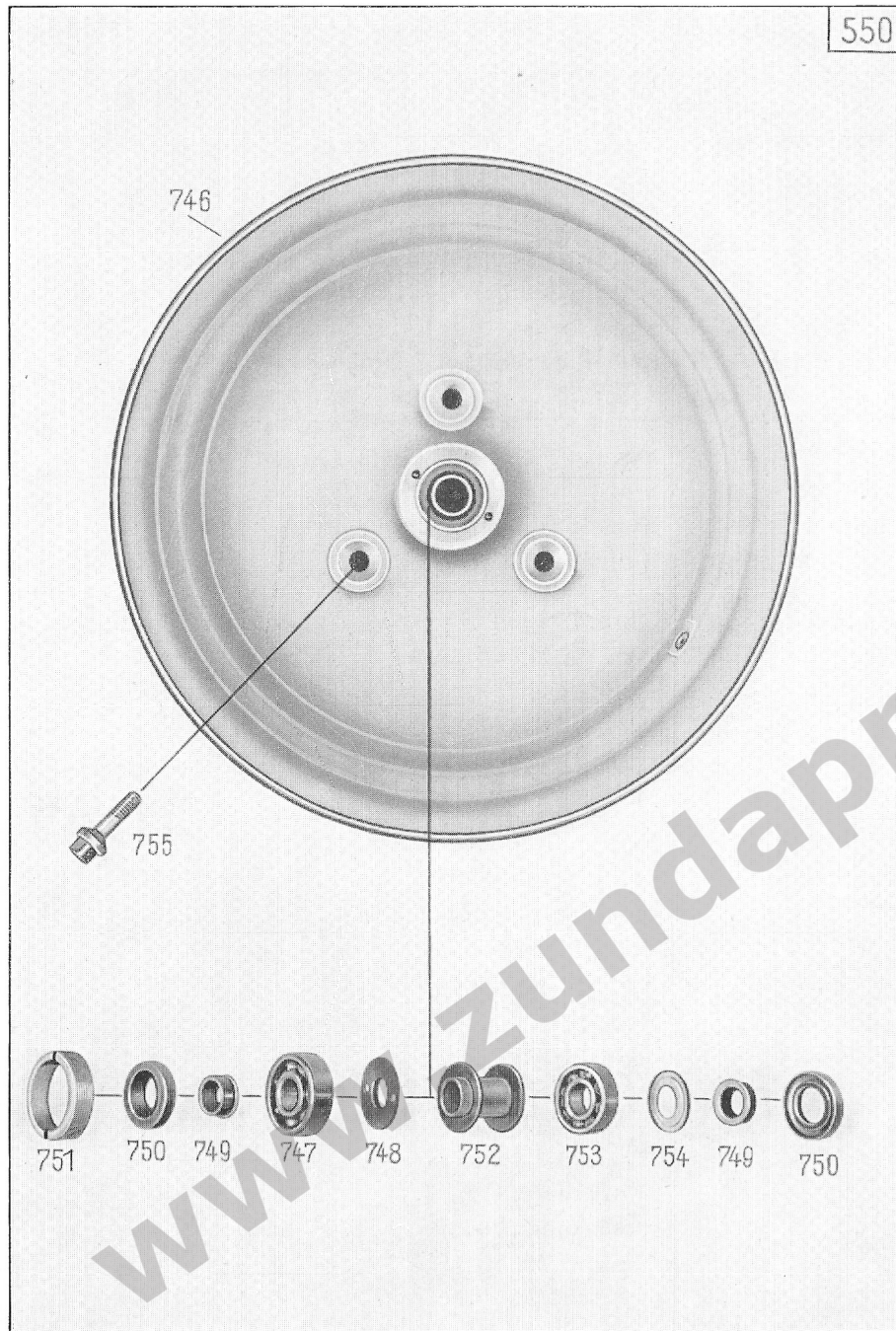

Illustration 27, Group B: b) Wheels

| Key No. | Spare Part No. | Description | No. of Pieces | Remarks |
|---------------|----------------|--|--------------------|---|
| Wheels | | | | |
| 746 | 6660 z 87 | wheel without tyre | 2 | |
| 747 | — | ball bearing 6302 DIN 625 | 2 | |
| 748 | 1301 z 641 | shim 15,2 × 36,6 × 0,1 | } as re- quired | } betw. ball bearing and spacer bushing |
| — | 1301 z 642 | shim 15,2 × 36,6 × 0,2 | | |
| — | 1301 z 643 | shim 15,2 × 36,6 × 0,3 | | |
| 749 | 171 z 412 | spacer bushing | 4 | |
| 750 | — | radial gasket (oil seal) with dust protection lip A 20 × 35 × 7 DIN 6503 | 4 | |
| 751 | 1011 z 84 | ring nut | 2 | |
| 752 | 1330 z 166 | spacer tube | 2 | |
| 753 | — | ball bearing 6202 DIN 625 | 2 | |
| 754 | 1231 z 305 | ring | 2 | |
| 755 | 1551 z 411 | square screw (for fixing wheel) .. | 6 | |

Illustration 28, Group E: a) Electrical Equipment, Headlight

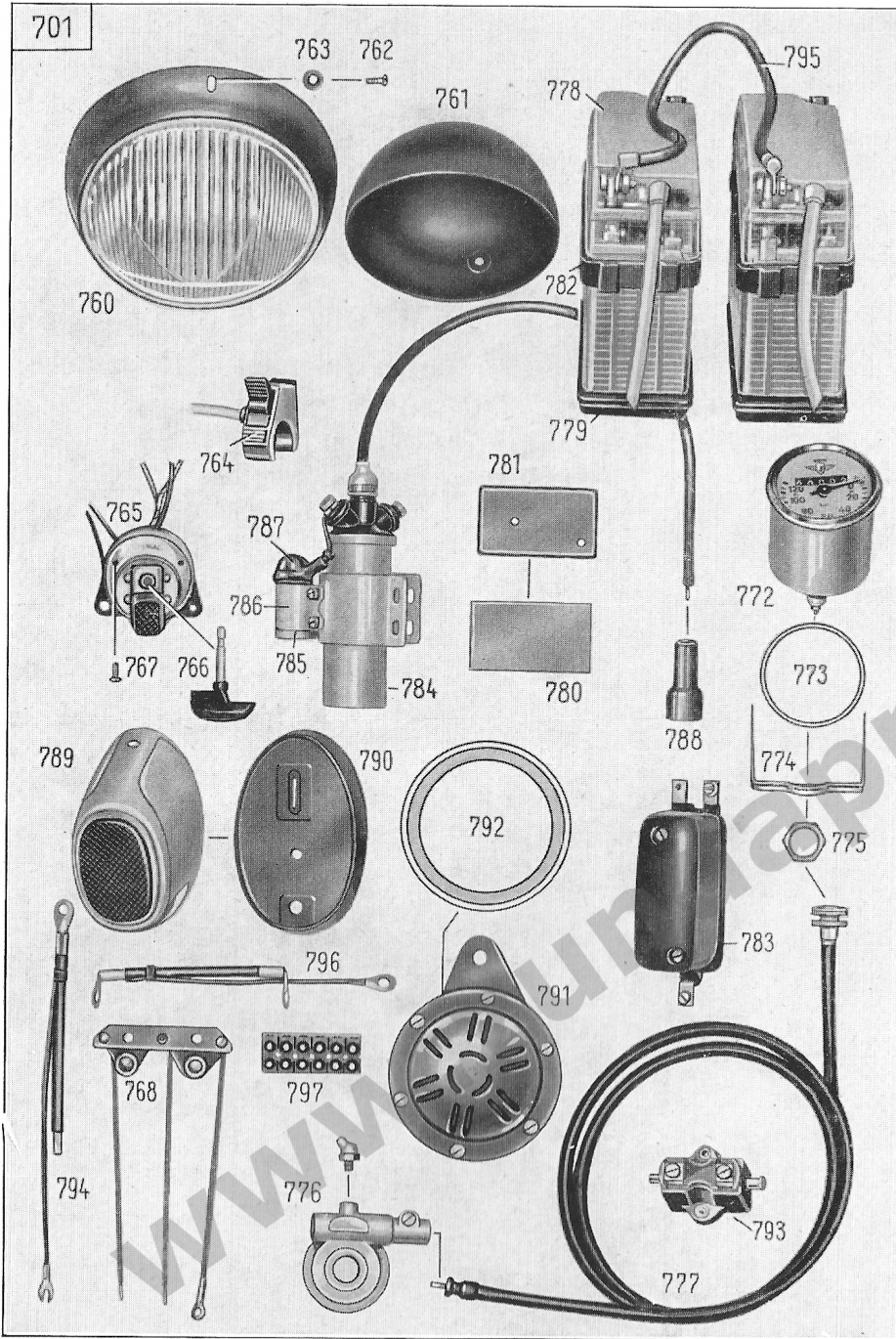

Illustration 28, Group E: a) Electrical Equipment, Headlight

| Key No. | Spare Part No. | Description | No. of Pieces | Remarks |
|-----------------------|----------------|--|---------------|------------|
| Headlight | | | | |
| 760 | 6090 z 105 | headlight (without bulbs) | 1 | |
| — | 2310 k 30-0 | reflector | 1 | |
| — | 2311 k 33-4 | rim | 1 | |
| — | 2317 k 7-0 | headlight glass | 1 | |
| — | 2316 k 8-0 | rubber ring (for headlight glass) .. | 1 | |
| — | 2310 k 38-3 | holder (to Bilux bulb) | 1 | |
| — | 2311 k 35-0 | retaining spring (to holder) | 1 | |
| 761 | 2316 k 7-0 | rubber cap | 1 | |
| — | 2311 k 36-8 | retaining ring (to rubber cap) | 1 | |
| — | — | Bilux bulb B 12 V 35/35 W DIN 72601 | 1 | Osram 7327 |
| — | — | parking light bulb H 12 V 2 W DIN 72601 | 1 | Osram 3796 |
| 762 | — | screw, countersunk raised head AM 4 × 10 DIN 91 crp (to fasten headlight to front cover) | 3 | |
| 763 | 1281 z 365 | washer | 3 | |
| 764 | 6160 z 154 | dip switch with set of cables | 1 | |
| — | 2340 k 1 | set of cables (4 lines) | 1 | |
| — | 2346 k 1 | rubber grommet | 1 | |
| within the dashboard: | | | | |
| 765 | 6160 z 180 | starter-ignition-light switch with key and cable | 1 | |
| 766 | 2310 z 50 | ignition key | 1 | |
| 767 | — | screw, countersunk raised head AM 4 × 12 DIN 91 crp (to fasten switch to dashboard) | 2 | |
| 768 | 6160 z 186 | holder (for charge control and idle control light) | 1 | |
| — | — | cylindrical screw AM 4 × 10 DIN 84 k (to fasten holder to dashboard) | 1 | |
| — | — | spring washer A 4 DIN 137 k | 2 | |
| — | 2310 k 51 | bulb 12 V 3 W | 2 | Osram 3766 |

Illustration 28, Group E: a) Electrical Equipment Speedometer, Battery, Taillight

| Key No. | Spare Part No. | Description | No. of Pieces | Remarks |
|----------------------|----------------|---|---------------|------------|
| Speedometer | | | | |
| 772 | 6770 z 57 | speedometer with lighting incorporated | 1 | |
| — | 6770 z 58 | speedometer indicating miles | 1 | |
| 773 | 2426 k 2-0 | rubber ring | 1 | |
| 774 | 2421 k 7 | retaining clip | 1 | |
| 775 | 2421 k 6-2 | hex. nut (to retaining clip) | 1 | |
| — | 2424 k 1-0 | bulb holder | 1 | |
| — | — | bulb J 12 V 2 W DIN 72601 | 1 | Osram 3898 |
| 776 | 6780 z 102 | drive (to rear wheel) | 1 | |
| 777 | 6790 z 108 | cable for drive | 1 | |
| — | 616 z 247 | rubber grommet (for clutch lever) | 1 | |
| — | 1806 z 108 | rubber grommet (for speedometer drive) | 1 | |
| Battery | | | | |
| 778 | 6060 z 104 | battery 6 V 11 Ah | 2 | |
| 779 | 1146 k 95 | battery base | 2 | |
| 780 | 1146 z 77 | rubber plate | 2 | |
| 781 | 1141 z 2125 | pressure plate | 2 | |
| 782 | 1236 z 337 | rubber ring | 2 | |
| Regulator | | | | |
| 783 | 6160 z 181 | regulator (to starter "Noris") | 1 | |
| — | — | cylindrical screw AM 4 × 6 DIN 84 k (to fasten regulator to front shield) | 3 | |
| — | — | spring washer A 4 DIN 127 k | 3 | |
| Ignition Coil | | | | |
| 784 | 6180 z 11-0 | ignition coil with ignition cable | 1 | |
| 785 | 2290 k 55-0 | condenser | 1 | |
| 786 | 2291 k 30-3 | fixing clamp | 1 | |
| — | — | cylindrical screw AM 4 × 6 DIN 84 k | 2 | |
| — | — | spring washer A 4 DIN 127 k | 2 | |
| 787 | 2296 k 9 | rubber cap | 1 | |
| 788 | 6080 z 102 | spark plug cover (Beru L 4 Z) | 1 | |
| Taillight | | | | |
| 789 | 6110 z 46 | brake-tail-number plate light | 1 | |
| — | 2320 k 6-8 | cap | 1 | |
| — | 2320 k 3-0 | glass (to cap) | 1 | |
| — | — | bulb M 12 V 3 W DIN 72601 (as tail bulb) | 1 | Osram 6428 |

Illustration 28, Group E: a) Electrical Equipment Horn, Brakelight Switch, Electric Conducts

| Key No. | Spare Part No. | Description | No. of Pieces | Remarks |
|-----------------------------------|----------------|--|---------------|------------|
| — | — | bulb K 12 V 15 W DIN 72601 (as brake bulb) | 1 | Osram 6451 |
| 790 | 1146 z 84 | supporting plate | 1 | |
| — | — | screw, button head AM 5 × 15 DIN 86 k (to fasten taillight to supporting sheet) | 1 | |
| — | — | screw, button head AM 5 × 18 DIN 86 k (to fasten taillight to supporting sheet) | 1 | |
| — | — | washer J 5,3 DIN 6798 | 2 | |
| — | — | hex. nut M 5 DIN 934 k | 2 | |
| — | 1331 k 870 | spacer tube (short) | 1 | |
| — | 1331 k 871 | spacer tube (long) | 1 | |
| Horn | | | | |
| 791 | 6130 z 19 | horn | 1 | |
| 792 | 1236 z 327 | rubber ring (betw. horn and front cover) | 1 | |
| — | — | hex. nut M 8 × 20 DIN 933 k (to fasten horn to front cover) | 1 | |
| — | — | spring washer A 8 DIN 127 k | 1 | |
| Brakelight Pressure Switch | | | | |
| 793 | 6160 z 158 | brakelight pressure switch | 1 | |
| — | 1141 z 2100 | fixing plate | 1 | |
| — | — | screw, button head AM 4 × 10 DIN 86 k (to fasten brakelight pressure switch to fixing plate) | 2 | |
| — | — | spring washer A 4 DIN 137 k | 2 | |
| Electric Conducts | | | | |
| — | 760 z 258 | set of cables, complete | 1 | |
| 794 | 760 z 252 | cable complete (ignition switch 30 — battery + — regulator cut-out) | 1 | |
| 795 | 760 k 253 | cable complete (battery + — battery —) | 1 | |
| 796 | 760 k 254 | cable complete (battery and case of regulator — earth) | 1 | |

Illustration 28, Group E: a) Electrical Equipment
**Horn, Brakelight Switch,
Electric Conducts**

| Key No. | Spare Part No. | Description | No. of Pieces | Remarks |
|---------|----------------|--|---------------|------------------------------------|
| — | 1391 z 167 | cable strand (cable set for headlight) | 1 | } for cable set and cables |
| — | 1396 z 51 | tie | 7 | |
| — | 1396 z 216 | tie | 1 | |
| — | 1146 z 79 | rubber plate | 1 | |
| — | 630 z 488 | cable support | 1 | |
| — | — | hex. screw M 6 × 18 DIN 933 k (to fasten cable support and rubber plate to frame) | 1 | } to fasten cable on steering head |
| — | — | spring washer B 6 DIN 137 k | 2 | |
| — | — | hex. nut M 6 DIN 934 k | 2 | |
| 797 | 6080 z 109 | terminal board | 1 | } |
| — | — | cylindrical screw AM 3 × 15 DIN 84 k (to fasten terminal board to front shield) .. | 2 | |
| — | — | spring washer A 3 DIN 137 k | 2 | |
| — | — | hex. nut M 3 DIN 934 k | 2 | |
| — | — | (Please order cables as well as sleeves resp. hoses by meters) | | |
| — | — | cable NYAF 0,840 m | | colour red |
| — | — | cable B 1,5 DIN 72551 2,660 m | | colour yellow |
| — | — | cable B 1,5 DIN 72551 0,820 m | | colour green |
| — | — | cable B 1,5 DIN 72551 1,070 m | | colour blue |
| — | — | cable B 1,5 DIN 72551 1,080 m | | colour blue/red |
| — | — | cable B 1,5 DIN 72551 3,475 m | | colour red |
| — | — | cable B 1,5 DIN 72551 0,750 m | | colour black |
| — | — | cable B 1,5 DIN 72551 1,540 m | | col. yell./green |
| — | — | cable B 1,5 DIN 72551 0,200 m | | colour red/yellow |
| — | — | cable B 1,5 DIN 72551 2,220 m | | colour black/white |
| — | — | cable shoe A 4 × 2 DIN 46211 | 6 | tinned |
| — | — | cable shoe A 5 × 3 DIN 46211 | 3 | tinned |
| — | — | cable shoe B 6 × 4,5 DIN 46211 .. | 3 | tinned |
| — | — | cable shoe C 5 × 3 DIN 46211 | 2 | tinned |
| — | 1806 z 01 | connecting protector | 1 | |
| — | — | connecting protector H DIN 72311 | 2 | |
| — | 1806 k 110 | connecting protector | 1 | |
| — | — | rubber hose 14 × 12 1630 mm | | |
| — | — | rubber hose 12 × 10 180 mm | | |
| — | — | rubber hose 10 × 8 1000 mm | | |
| — | — | rubber hose 8 × 6 180 mm | | |
| — | — | rubber hose 5 × 4 380 mm | | |

Illustration 29, Group E: a) Electrical Equipment, Starter Generator

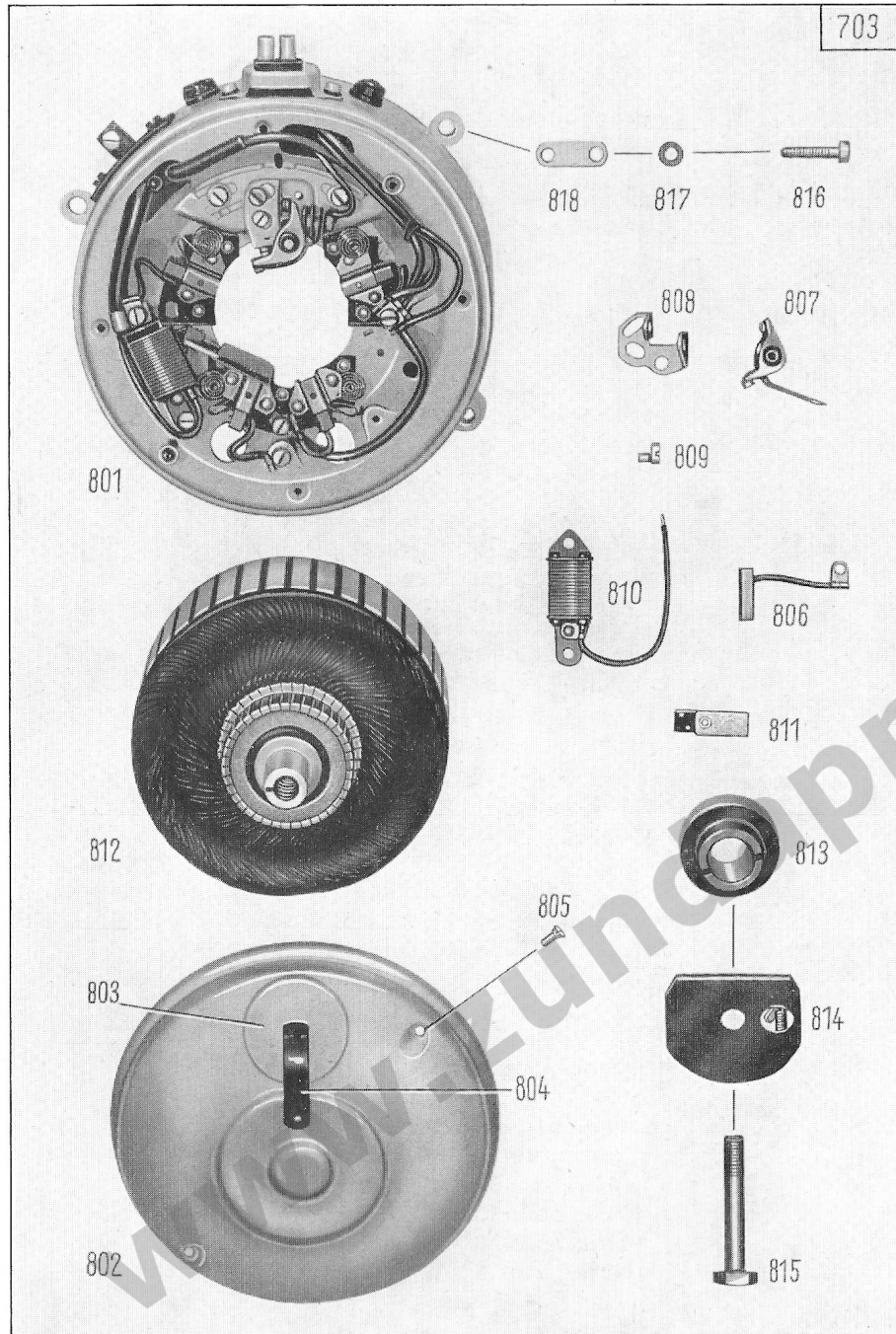

Illustration 29, Group E: Electrical Equipment, Starter Generator

| Key No. | Spare Part No. | Description | No. of Pieces | Remarks |
|--------------------------|----------------|---|---------------|---------------------------------------|
| Starter Generator | | | | |
| 801 | 6210 z 1 | starter generator model Noris LA 12/100/3 L 12 V 100 W | 1 | |
| 802 | 2291 k 33-3 | protection cover | 1 | |
| 803 | 2291 k 34-3 | cap (for protection cover) | 1 | |
| 804 | 2291 k 35-0 | laminated spring | 1 | |
| — | 2291 k 36-0 | rivet, button head (to fasten laminated spring to protection cover) | 1 | |
| 805 | — | screw, countersunk raised head M 4 × 6 DIN 88 k (for fixing the protection cover) | 2 | |
| 806 | 2290 k 58-0 | carbon brush with cable | 4 | |
| — | 2291 k 37-0 | pressure spring (to carbon brush) | 4 | |
| 807 | 2290 k 30-6 | contact breaker arm with contact | 1 | |
| 808 | 2290 k 35-6 | contact bracket | 1 | |
| 809 | 2291 k 26-3 | eccentric screw | 1 | |
| — | — | cylindrical screw M 4 × 8 DIN 84 k | 1 | |
| 810 | 2290 k 59-0 | resistance | 1 | |
| 811 | 2290 k 36-0 | laminated spring with felt | 1 | |
| — | 2291 k 15-2 | rivet (to laminated spring) | 2 | |
| 812 | 2290 k 60-0 | armature | 1 | |
| 813 | 2290 k 61-0 | interruptor cam | 1 | |
| 814 | 2290 k 62-0 | flyball governor | 1 | |
| — | 2291 k 38-0 | spring (to flyball governor) | 1 | |
| — | — | key 4 × 5 DIN 6888 (to fasten arma- ture on crankshaft) | 1 | |
| 815 | 2291 k 39-2 | hex. screw (for fixing armature) .. | 1 | |
| — | — | spark plug with gasket 14 DIN 72502 | 1 | Bosch W 225 T 11 or Beru 225/14 u2 |
| 816 | — | cylindrical screw AM 6 × 25 DIN 84 k (to fasten starter generator to crankcase) | 4 | |
| 817 | — | spring washer A 6 DIN 127 k | 4 | |
| 818 | 1281 z 391 | joint (to fasten clutch cable to starter) | 1 | |
| — | 1806 k 110 | connecting protector | 1 | |



| Key No. | Spare Part No. | Description | No. of Pieces | Remarks |
|--------------|----------------|--|---------------|----------------------------|
| Tools | | | | |
| — | 6890 k 43 | set of tools | 1 | |
| 821 | 6040 z 273 | bag for tools | 1 | |
| 822 | — | double end spanner 7 × 9 mm DIN 895 | 1 | |
| 823 | — | double end spanner 8 × 10 mm DIN 895 | 1 | |
| 824 | — | double end spanner 14 × 17 mm DIN 895 | 1 | |
| 825 | 2011 k 104 | one end spanner 19 mm with tyre lever | 1 | |
| 826 | 2021 z 51 | square socket wrench | 1 | |
| 827 | 2021 z 56 | socket wrench (to spark plug) | 1 | |
| 828 | 1671 z 02 | mandrel 10 mm ϕ | 1 | |
| 829 | 2001 z 15 | mandrel 7 mm ϕ | 1 | |
| 830 | 2001 z 01 | tyre lever | 1 | |
| 831 | 2009 z 01 | screw driver | 1 | |
| 832 | 2021 z 23 | socket wrench (to carburettor) | 1 | |
| 833 | 2208 k 12 | cleaning cloth | 1 | |
| 834 | 6040 k 269 | box with rubber repairing material | 1 | obtainable in the trade |
| 835 | 6040 k 255 | air pump (without hose) | 1 | |
| — | 1596 z 291 | hose sleeve (to air pump) | 1 | |